

# locktronics

Simplifying Electricity

## Electrical installation 2



CP8475

**MATRIX**

[www.matrixtsl.com](http://www.matrixtsl.com)







Copyright © 2015 Matrix Technology Solutions Ltd.

Introduction	3
Circuit training	4
Power supplies	5
AC vs DC	7
Measuring AC	9
AC and DC again	10
Conductors and insulators	11
Circuit diagrams	12
Current path	13
Effects of electric currents	15
Motor effect	19
Connect in series	23
Connect in parallel	24
Series / parallel	25
MES bulbs	27
Series / parallel applications	28
Staircase circuit	29
3-way control	33
Measuring voltage	35
Measuring current	39
Kirchhoff's voltage law	43
Kirchhoff's current law	44
Resistance	45
Ohm's law	47
Measuring resistance	49
Resistivity	51
Electrical safety	54
The fuse	55
The circuit breaker	56
The RCD	57
Earthing	58
The energy meter	59
Measuring power	60
Energy and power	61
Electromagnetism	62
Generating electricity	64
Transformers	66
Step-down transformer	68
Step-up transformer	69
Transformer relationships	70
Student Handbook	71
Instructor Guide	100

The course aims to prepare you for Unit 202 - “Principles of Electrical Science” part of the City and Guilds Level 2 Diploma in Electrical Installations qualification.

As you work through the course, the layouts show you how to build the systems and each task details how to test them.

There are a variety of different tasks, identified by a series of icons.

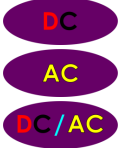
Icon	Significance
	Content gives information about electricity, or explains some terminology
	Practical activity
	Relates the current activity to jobs in the industrial / domestic realm
	Open-ended activity where the students designs the activity
	Health and Safety related issue
	Activity involves a formula or calculation
	Power supply flags indicate which type of power supply to use.

For your records:

- It is important that you keep accurate records of what you do.
- A Student Handbook will be issued to assist with these records.
- In addition, take whatever notes you feel are necessary to help with this.

This activity is **optional**.

- If you recently followed 'Electrical Installation 1', it is probably unnecessary.
- If you are new to Locktronics, it is a useful way to introduce the kit.

## Over to you

Build a circuit that makes a bulb light, using a 12V 0.1A bulb and the 12V AC power supply.

The hardware:

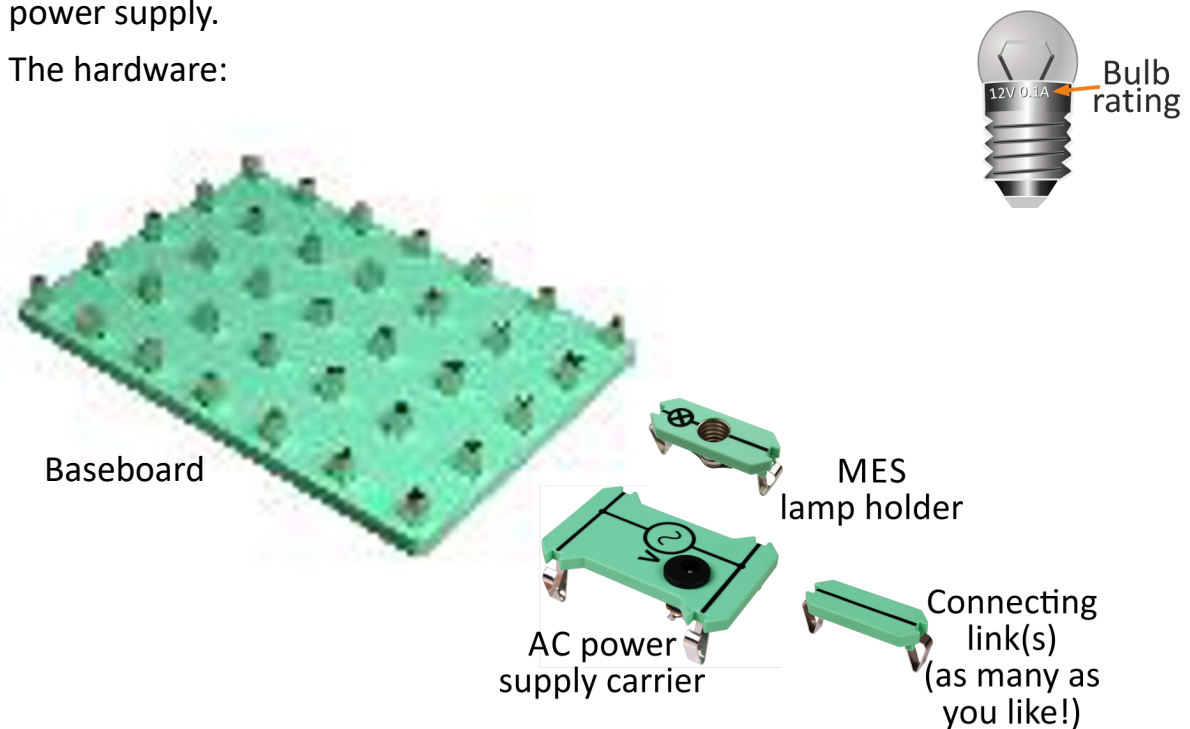

Answer the question in the Student Handbook.



### Power supply:

- drives current around the circuit;
- has two terminals (connection points) one 'positive' the other 'negative';
- current flows from the positive terminal to the negative terminal.

### DC power supply - (DC = direct current):

- one terminal is always positive, the other always negative;
- 'one-way traffic' - current always flows the same way around the circuit.

### AC power supply - (AC = alternating current):

- one terminal positive, the other negative and then they swap, repeatedly;
- 'two-way traffic' - current flows clockwise, then anticlockwise around the circuit.



# Power supplies - 1

The difference between DC and AC is best shown by looking how the voltage changes over a period of time, i.e. looking at a voltage / time graph.

These can be produced using an **oscilloscope**.



Used more in electronics, they display the signal as a graph, with voltage on the vertical axis and time on the horizontal axis.

Some digital oscilloscopes, like the 'Picoscope', which produced the signals shown below, generate signals which are processed by a computer connected to it.

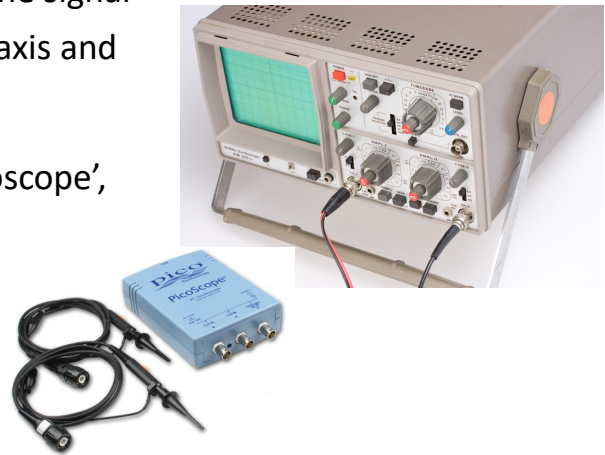

**DC power** - the voltage stays steady over a period of time.

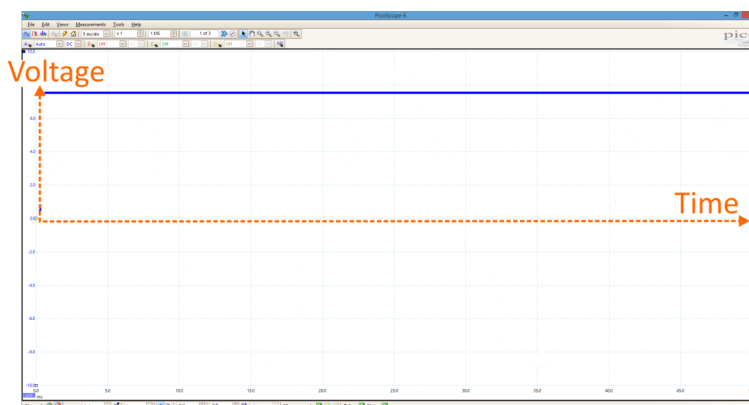

**AC power** - the voltage changes all the time and even goes negative sometimes.

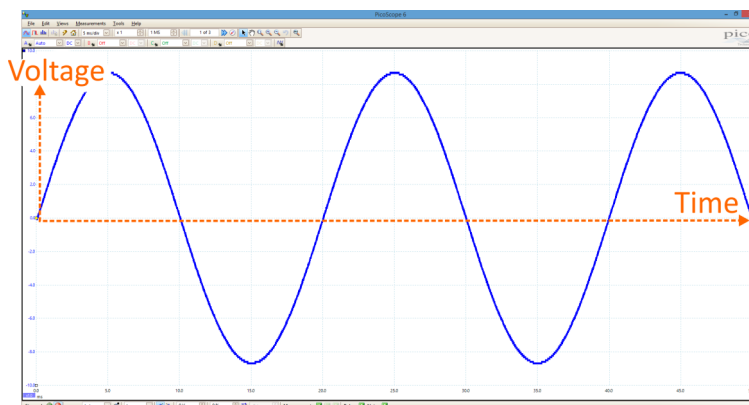



## AC or DC - which is used?

Each has its uses!

Electricity is usually generated and transmitted as AC because:

- alternators are generally more efficient than dynamos;
- transformers can modify voltage and current efficiently.

Electronic devices - mobile phones, computers, televisions etc. usually require DC.

### AC power:

can be converted into DC using the processes of rectification and regulation.

### DC power:

can be converted into AC using a device called an inverter.

### DC power supplies:

- **battery** - chemical reactions generate DC voltages, e.g. 'lead-acid' batteries;
- **solar cell** - photo-voltaic ('solar') cells convert light energy into DC electricity ;
- **dynamo** - a rotating coil of wire near a magnet generates DC using a 'commutator' to connect the coil to the rest of the circuit.



### AC power supplies:

- **alternator** - another example of a rotating coil of wire near a magnet;
  - a 'slip-ring' connects to the rest of the circuit;
  - the coil can be driven by:
    - high-pressure steam, in a power station;
    - wind in a wind-generator;
    - falling water in a hydro-electric power station.

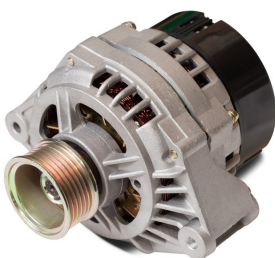

The aim of this and the next activity is to compare the performance of an AC and a DC power supply.

Preliminary experiment - finding two bulbs that have the same brightness

## Over to you

Build the layout shown below.

The lamps are connected in parallel and should be equally bright.

If not, change the bulbs until you find two that are equally bright.

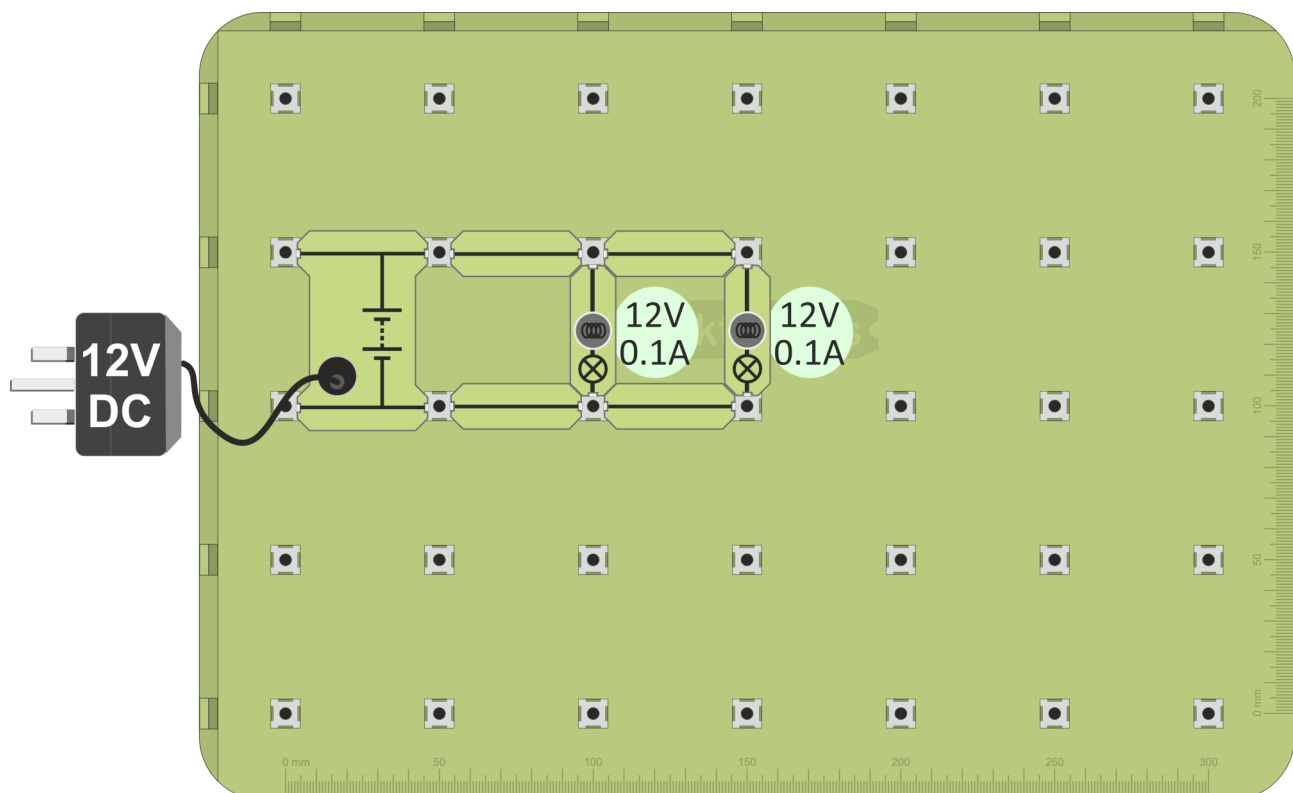

Use

these

bulbs in the next activity, which has two circuits, one lamp powered by DC, and an identical lamp powered by AC.

## AC versus DC - 2

This activity continues the task of comparing the AC and DC power supply.

### Over to you

1. Build the layout shown below, using the two bulbs from the previous activity.  
There are two circuits, one lamp powered by DC, and an identical one powered by AC.
2. Connect the DC power supply, set to 12V, and the AC supply.
3. Switch both on.

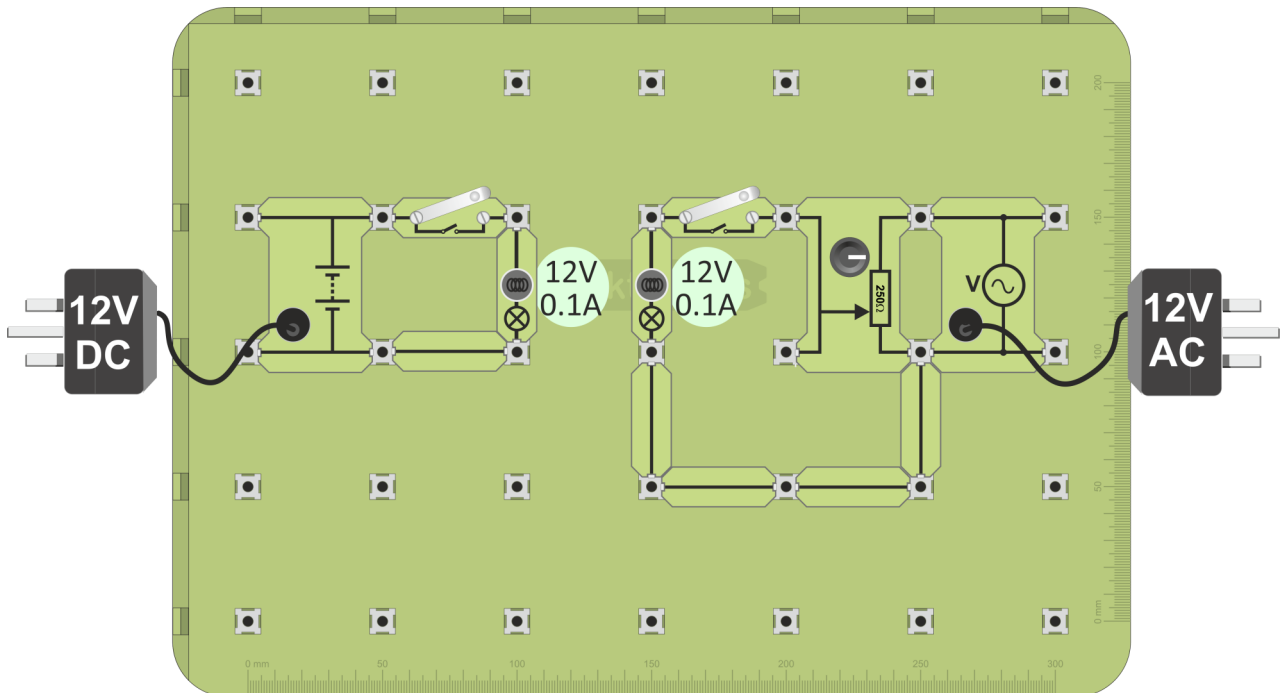

4. Adjust the 250Ω 'pot' until the two lamps have the same brightness.  
Now, the AC voltage has exactly the same effect as the DC supply.
5. Connect a multimeter, set to the 20V DC range, to read the voltage across the DC-powered lamp. This gives the rms value of the AC voltage.
6. Record the reading in the Student Handbook.



## Measuring AC:

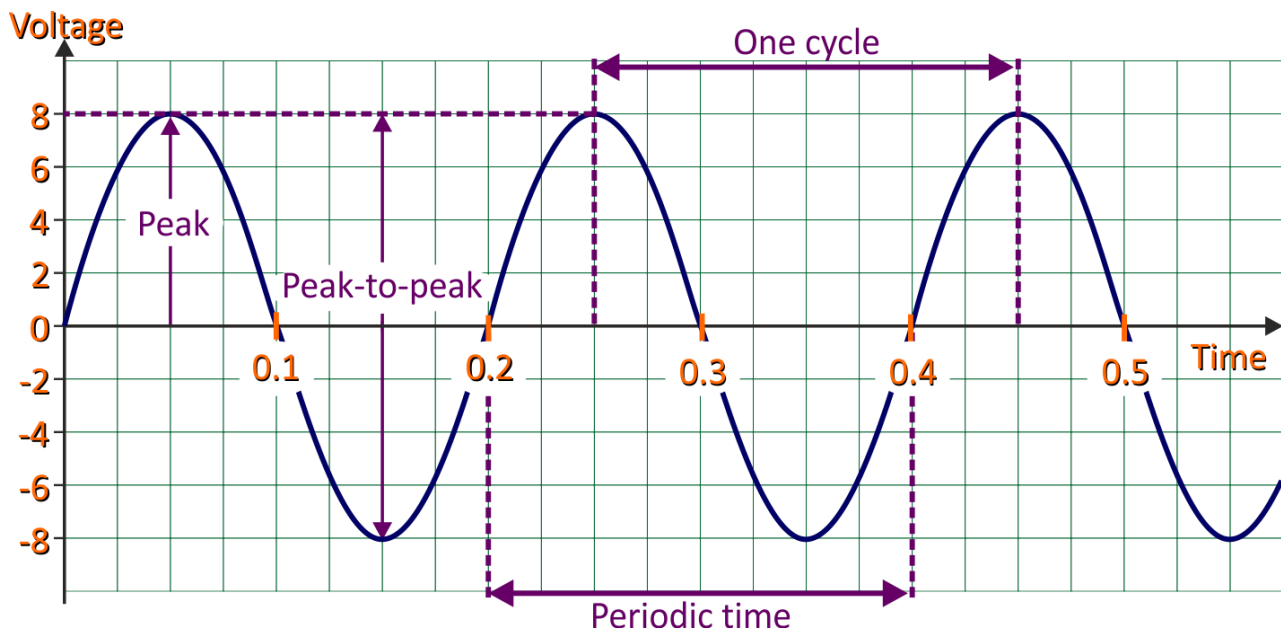

The diagram shows the voltage / time graph for an AC signal, labelled with some important quantities:

- **Peak voltage** - maximum voltage reached by the signal, (8V in this case).
- **Peak-to-peak voltage** - voltage difference between positive peak and negative peak voltage, equals two x peak voltage, (16V in this case).
- **Periodic time** - time to get back to its 'starting point';  
- time taken for one complete cycle, (0.2s in this case).

Related to these is the **frequency f** of the signal - the number of cycles completed in one second.

The relationship is logical:

$$f = 1 / T \quad \text{where } T \text{ is the periodic time.}$$

Frequency is measured in units called hertz (Hz). A frequency of 10 Hz means that ten cycles of the wave are completed each second.

For the AC signal shown above, the frequency is:

$$\begin{aligned} f &= 1 / 0.2 \\ &= 5\text{Hz} \end{aligned}$$

Now answer the questions in the Student Handbook!

## Issues about AC power:

- The average voltage is zero.

Looking at the voltage / time graph on the previous page, the voltage is positive for half of the time and negative for half of the time. Over one cycle, these cancel out, leaving an average value of zero.

- The peak voltage may be 8V, but most of the time the voltage is much less.

So what is the “average” effect of an AC supply and how can we compare AC and DC?

The previous activities give the answer - look for the two power supplies having the same effect on a device like a bulb.

The graph shows the AC and DC power supply signals from that activity, where the two bulbs had the same brightness - AC and DC were having the same effect.

Notice that the DC supply voltage sits well below the AC peak value.

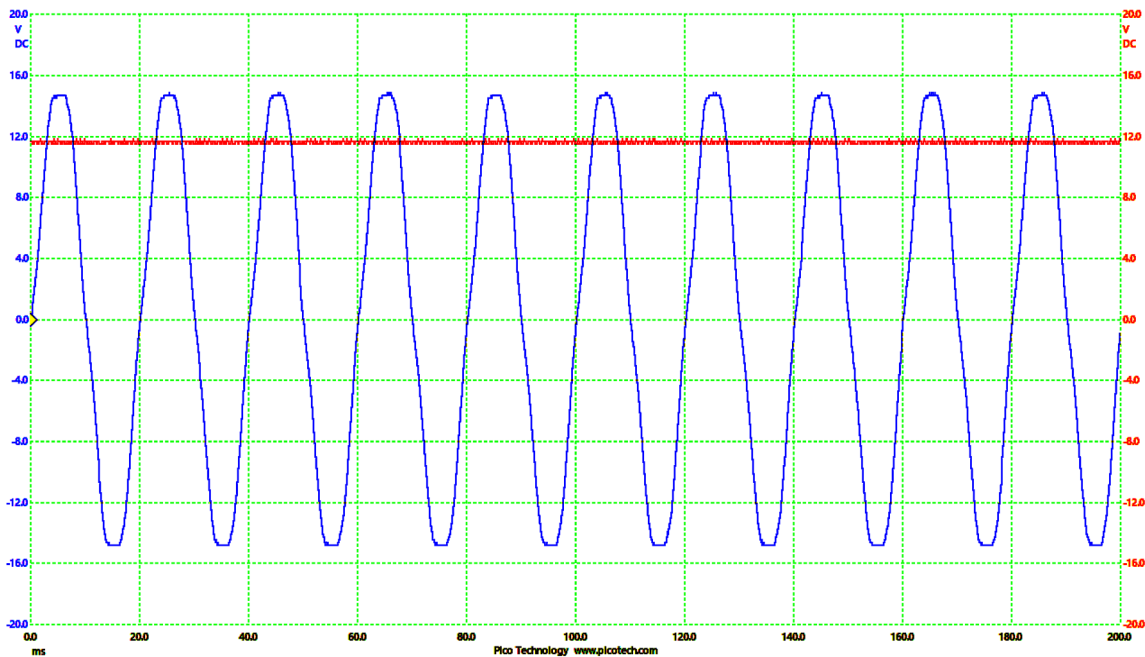

It is called the **r.m.s.** value of the AC supply, related to the peak value by the formula:

$$V_{\text{rms}} = 0.7 \times V_{\text{peak}}$$

or, re-arranging this:

$$V_{\text{peak}} = V_{\text{rms}} / 0.7$$

The AC signal in the graph has a peak value of ~ 15V, giving a r.m.s. voltage of  $15 \times 0.7 = \sim 10.5\text{V}$ . ( The DC voltage shown in the graph is close to this!)

For an AC signal with a r.m.s. value of 35V, the peak voltage would be  $35 / 0.7 = 50\text{V}$ .

Now answer the questions in the Student Handbook!

# Conductors and Insulators



Materials which pass electricity are called **conductors**.

Materials which do not pass electricity are called **insulators**.

The hardware:



Universal component carrier

Over to you **DC/AC**

1. Build the layout shown below.
2. Connect the 12V power supply and switch on.

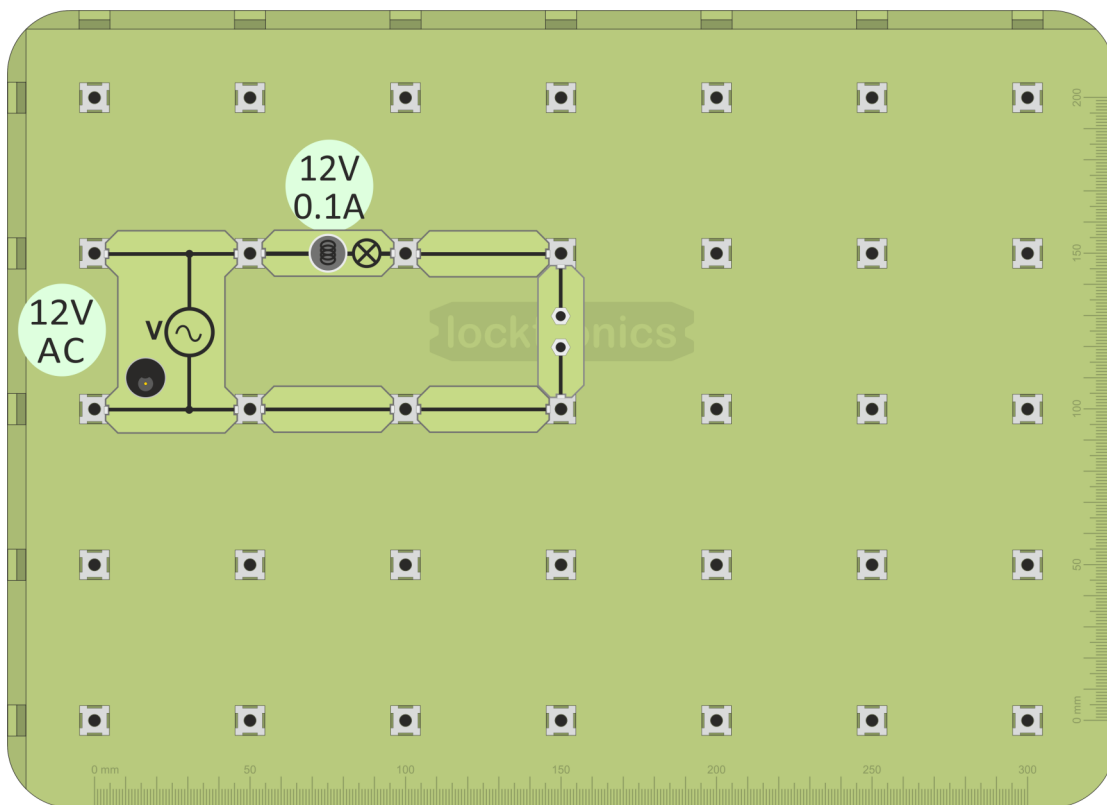

3. Put different materials across the gap in the universal component carrier. See if the bulb lights. (We are using the bulb as a simple continuity tester.) If it does, the material is a conductor; if not, it is an insulator (roughly speaking). Try some of the following:
  - kitchen foil (aluminium), a rubber, paper, polythene, copper, air, lead, pencil lead (graphite), glass, wood, a coin, a piece of cloth, a plastic pen.
4. Fill in the table on the Student Handbook with the findings from your experiment and try to answer the question.



The aim is to clarify how a circuit is built, using an internationally recognised set of symbols.

You have already been exposed to some - Locktronics carriers all show the conventional symbols for the components they carry.

Here is a summary of the ones used so far:

AC power supply	Battery or DC power supply	Toggle switch	Push switch	Lamp	Resistor

## Over to you

DC

1. Build each of the three circuits, shown in circuit diagrams **A**, **B** and **C**, in turn. Each one uses a 12V DC power supply and 12V 0.1A bulbs.
2. Use the brightness of the bulbs to decide which circuit draws the biggest current from the power supply.
3. Record your decision in the Student Handbook.

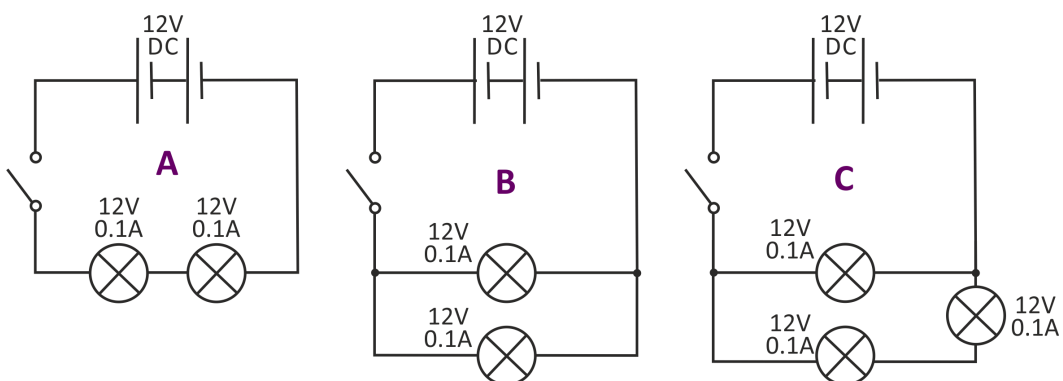



# Current path - 1



## Power supply:

- drives current around the circuit;
- has two terminals (connection points) one 'positive' the other 'negative';
- current flows from positive to negative.

**Connecting links:** allow current to flow freely.

**Circuit:** continuous length of conductor joining the power supply terminals.

## Over to you

DC/AC

1. Build the layout shown below.
2. Connect the 12V power supply and switch on.

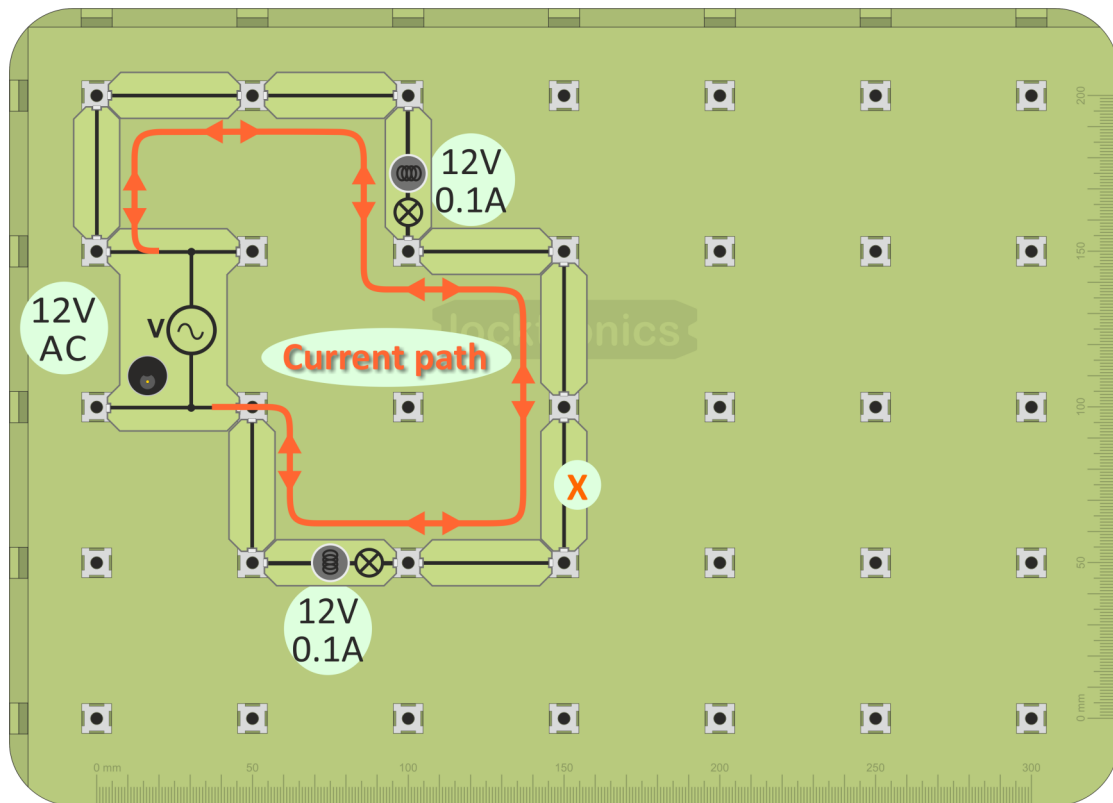

3. What happens if you remove a connecting link (for example 'X' - or any other)?
4. What happens if you unscrew one of the bulbs?

## Challenge

Try other circuit shapes.

(Make sure that there are no 'branches' (junctions) in your circuits - these are covered later!)

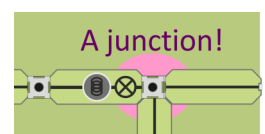

Does the shape make any difference to the way the circuit works?

Swap the AC power supply for a 12V DC supply. Does that make any difference?

Answer the questions posed in the Student Handbook!



- When a fuse blows, it stops the current flowing to all devices, just like removing a connecting link.
- Turning off a switch has the same effect.

The diagram shows how to wire up a pendant light to a ceiling rose and control it with a switch.

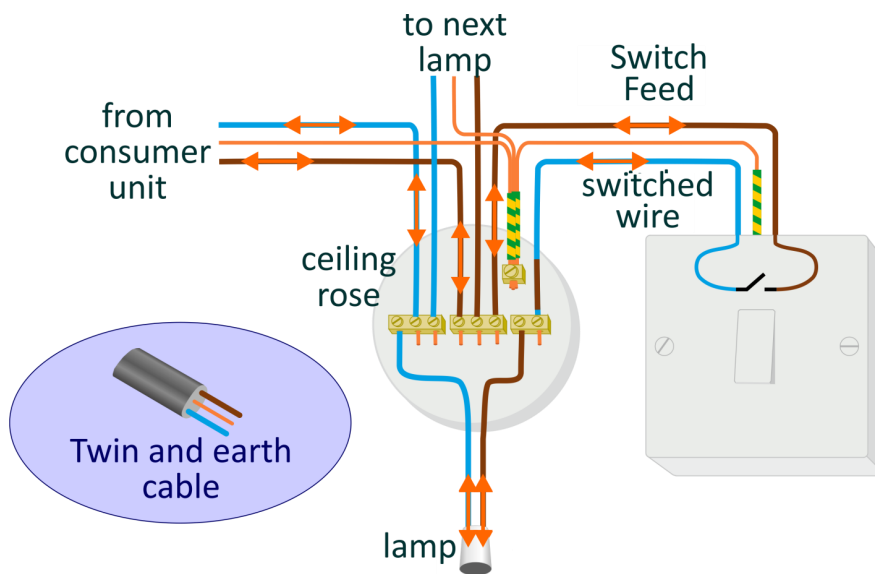

Domestic wiring is slightly different from the circuit you just built. It uses 'twin and earth' cable, containing a 'line', a 'neutral' and an 'earth' cable, bound together in a grey pvc sheath, for protection, rather than using separate single wires.

It is still connected in circuits allowing current to flow from one terminal of the power supply to the other.



The orange arrows show the current path through this circuit. Trace it yourself to check that you understand it.

Follow it from the consumer unit:

- through the switch,
- through the lamp,
- back to the consumer unit.

## Effect 1 - Heating effect

Over to you **DC/AC**

1. Build the layout shown below.
2. Connect the power supply, set to 12V, and switch on.

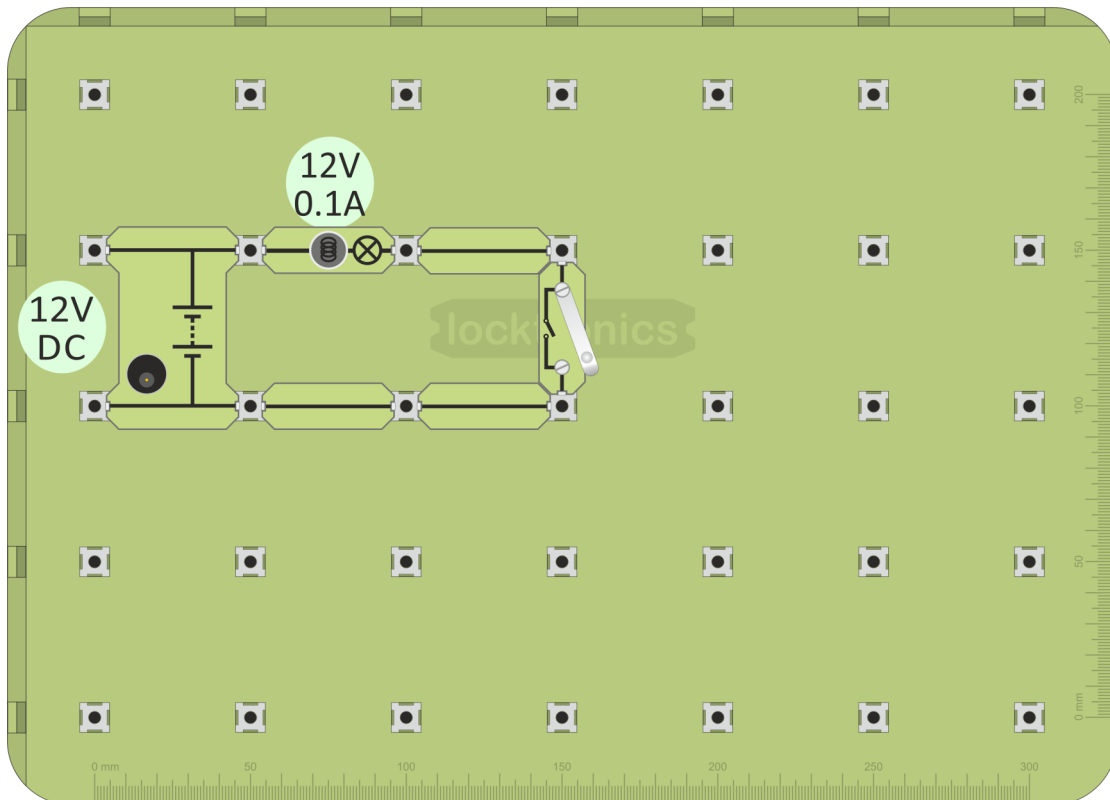

3. Close the switch. The lamp filament should be glowing yellow-hot.
4. Take hold of the glass envelope of the lamp. Does it feel warm?
5. Switch it off.
6. Clamp a few strands of wire wool between the posts of the universal component carrier, as shown in the diagram.
7. Remove the lamp holder from the circuit and replace it with the universal component carrier.
8. Close the switch and look at the wire wool strands. There should be a noticeable heating effect!



**(Take care not to touch the component - it will be extremely hot!)**

# Heating effects

When an electric current flows through a material, its energy is converted to heat.



You've seen a common example of this heating effect already - the filament lamp.



The filament, the coil of wire at the centre of the glass 'bulb', usually made of the metal tungsten, is heated by the current to such a high temperature, over 2000<sup>0</sup>C, that it glows yellow-hot, giving out light.



Problem - they are very inefficient.

Typically only ~5% of the electrical energy used appears as light.

LED (Light-Emitting Diode) lighting can be ten times more efficient.



In the home, electricity supplies a host of other heating appliances, as the picture shows.



The reverse effect is seen in a thermocouple.

Two legs, made from different metals, are connected together. When this junction is heated, it generates a DC voltage. Thermocouples are used to measure temperature.





# Effects of electric currents - 2

## Effect 2 - Magnetic effect

The hardware - a 400 turn coil mounted on a carrier:

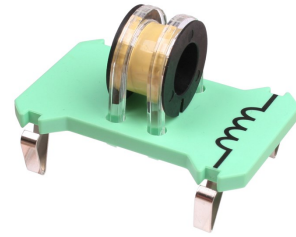

Over to you **DC**

1. Build the layout shown below.
2. Connect the DC power supply, set to 12V, and switch on.

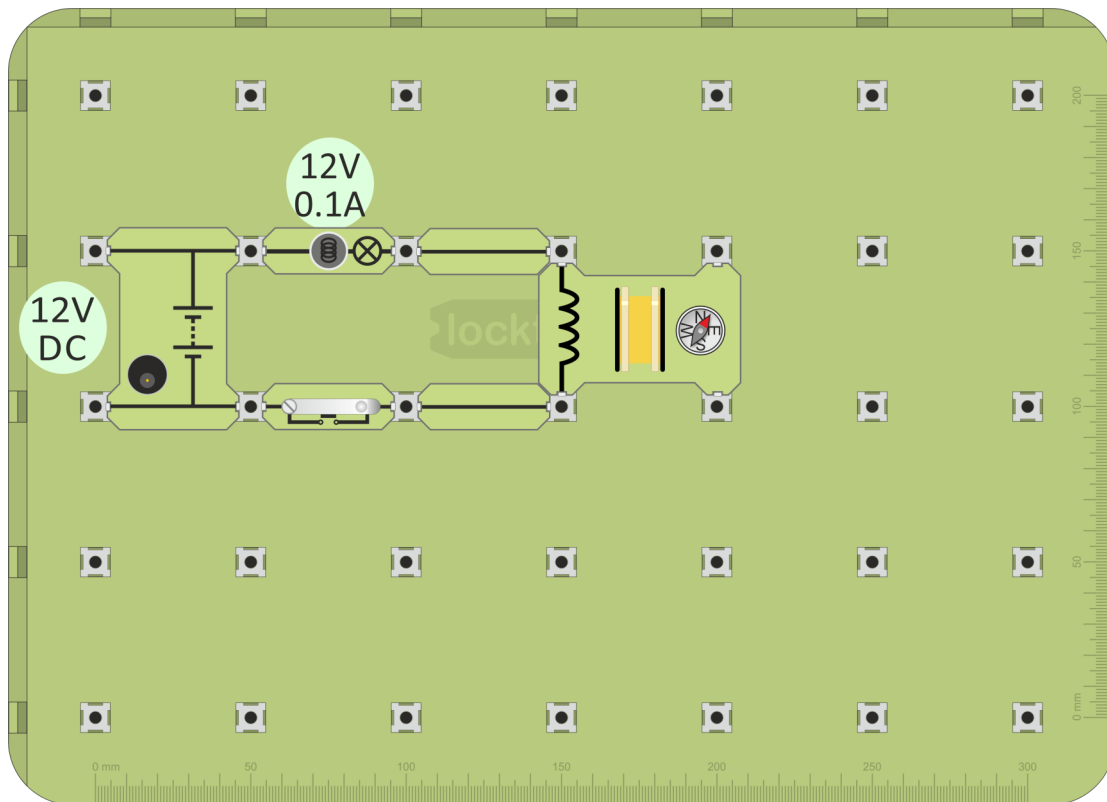

3. Place a magnetic compass next to the coil, as shown.
4. Close the switch and watch the compass needle as you do so.
5. Now switch off and place a steel nail inside the coil.
6. Close the switch again, watching the needle as you do so.  
Is the effect stronger than before?
7. Wave a magnet near the compass. The effect should be the same.  
This confirms that the coil was generating magnetism.

# Magnetic effects

An electric current is **ALWAYS** accompanied by a magnetic field.



The principal application of this magnetic effect is the electric motor.

There are many examples of its use in the home.  
(Some involve heating as well as magnetic effects.)

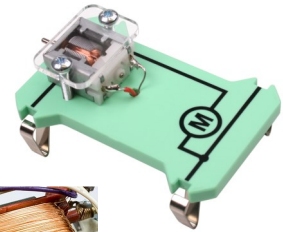

Other applications of electromagnetism include:

- transformers - in power supplies, such as mobile phone chargers;
- generators - used to power tools or as a stand-by in case of power cuts;
- loudspeakers - in radios, televisions, computers and mobile phones;
- circuit breakers - another protection against current overload and overheating.

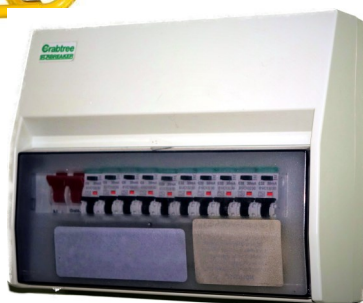

# Motor effect - 1

An electric current produces a magnetic effect.

Magnets exert forces on each other.

It is not surprising, then, that when a magnet is placed near a current-carrying coil, the coil moves - it's an electric motor!

This investigation uses the motor-effect carrier, shown opposite. It has two fixed conductors, with a moveable metal rod sitting across the top, connecting them.

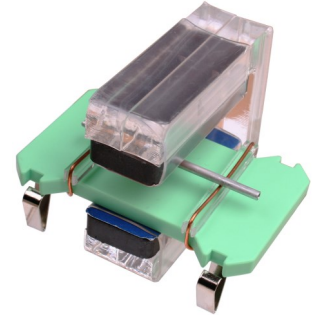

1. Build the system shown in the following picture.

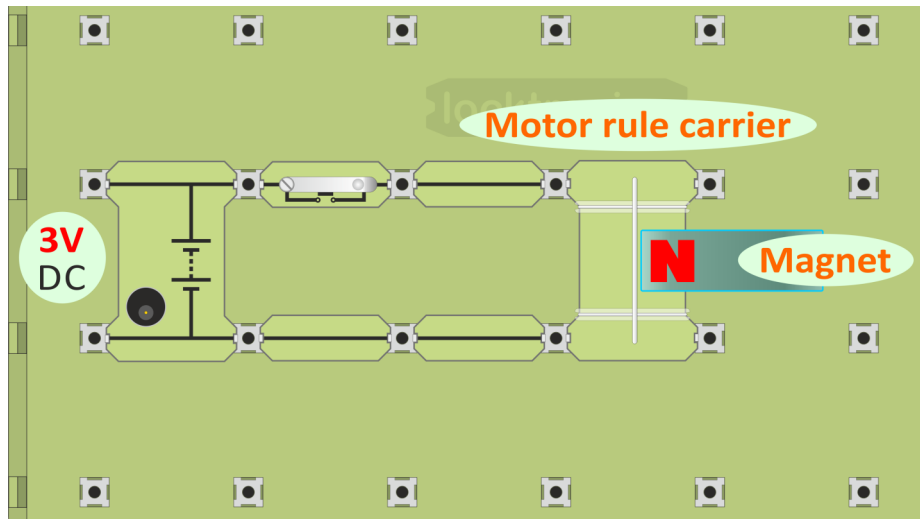

For clarity, the magnet has not been pushed right over the metal rod. Push it right across, so that the moveable rod sits directly under the magnet.



**Notice - The power supply is set to 3V initially!**

2. Press the push switch, and notice what happens.
3. Next, flip the magnet over so that the South pole is on top.
4. Press the push switch again.  
What is the difference?
5. Reverse the current direction - turn the power supply carrier so that the negative end (short line on the symbol) is at the top.  
What happens now when you press the push switch?
6. Increase the power supply voltage to 12V, to increase the current flowing through the rod.  
Can you see any difference when you close the push switch?

## Fleming's Left-hand Rule:

John Ambrose Fleming devised a way to work out the direction a wire will move in (also known as the *motor rule*):

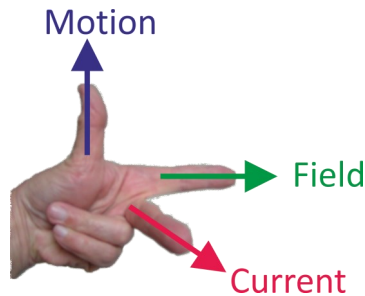

- Clamp your **left**-hand to the corner of an imaginary box, so that thumb, fore-finger and centre-finger are all at right-angles to each other.
- Line up the **F**ore-finger so that it points along the magnetic **F**ield (from North pole to South pole,)
- Line up the **C**entre-finger with the direction of the **C**urrent (from positive battery terminal to negative.)
- The thu**M**b now points in the direction of the resulting **M**otion.

The principle of a single coil DC motor is shown opposite.



Use Fleming's Left-hand Motor rule to obtain the direction of rotation of the coil.

(You should find that it rotates anti-clockwise, viewed from the battery.)

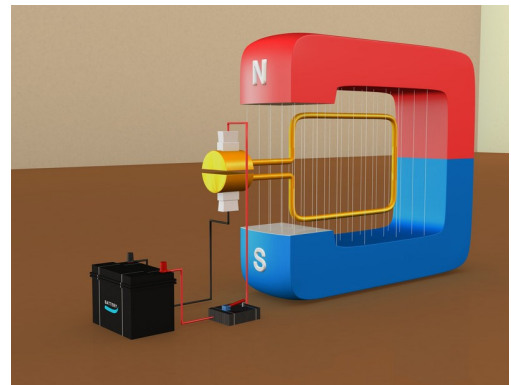

Practical DC motors use multiple coils, to smooth out the torque.

They may also use an electromagnet instead of a permanent magnet.





## Effect 3 - Chemical effect

Over to you

DC

(Optional experiment)

1. Build the layout shown below.  
The lamp is included so that you can see when an electric current is flowing.
2. Connect the 12V DC supply and switch on.

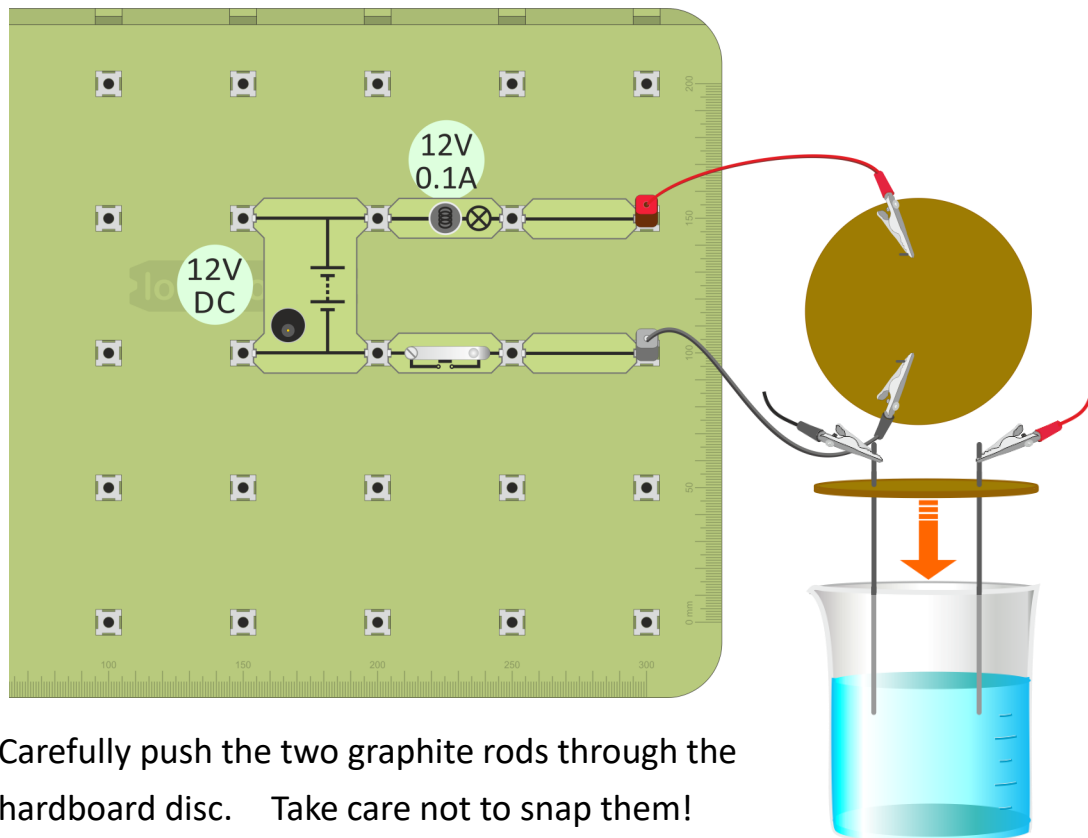

3. Carefully push the two graphite rods through the hardboard disc. Take care not to snap them!



**Now put on goggles to protect your eyes.**

4. Pour about 200ml of the copper sulphate solution into a 250ml beaker.  
This concentration of copper sulphate is not hazardous, but make sure that you wash your hands at the end of the investigation.
5. Lower the rods into the beaker, so that the disc sits on top of the beaker.
6. Connect the rods to the rest of the circuit using crocodile clips.
7. Close the switch and watch carefully to see what is happening in the beaker.  
**A chemical reaction is taking place, driven by the electric current.**



**Warning about copper sulphate solution:**

Harmful if swallowed. Irritating to eyes and skin. Very toxic to aquatic organisms, may cause long-term adverse effects in the aquatic environment.  
**See CLEAPSS Hazard 27C for further details.**

# Chemical effects



**An electric current can create/be created by a chemical reaction.**

An electric current is a flow of electrons, (which are tiny particles found in all atoms.)

A chemical reaction involves electrons transferring between atoms. No wonder electric currents and chemical changes are related!

The most obvious example of this link is the battery.

In 'dry' batteries, a chemical reaction generates a voltage which can drive an electric current.

In rechargeable batteries, this process can be reversed - a current flowing the 'wrong' way can reverse the chemical reaction, storing up energy for later use.



Another example is the technique known as electroplating. In this, an electric current flowing through a chemical solution deposits a metal on one of the electrodes.

This may be done:

- for protection - objects made from iron can be protected from corrosion by plating them with zinc (galvanising);
- for decoration - objects made from a cheaper metal can be plated with a more expensive one such as gold or silver.



Electrolysis is a related technique.

Here, the electric current is used to extract or purify chemicals such as chlorine and copper.

# Connect in series



## Series:

- devices connected one after the other in a line;
- no alternative routes, no branching;
- only one path for the current through the connection.

**Remember! - the brighter the bulb, the bigger the current!**

## Over to you

DC/AC

1. Build the layout shown opposite.  
This is a series circuit - the lamps are connected in a line with no junctions.
2. Connect the 12V power supply.
3. Switch on. What do you notice about the brightness of the three lamps?
4. What happens if you unscrew one of the bulbs (bulb 'X' for example)?

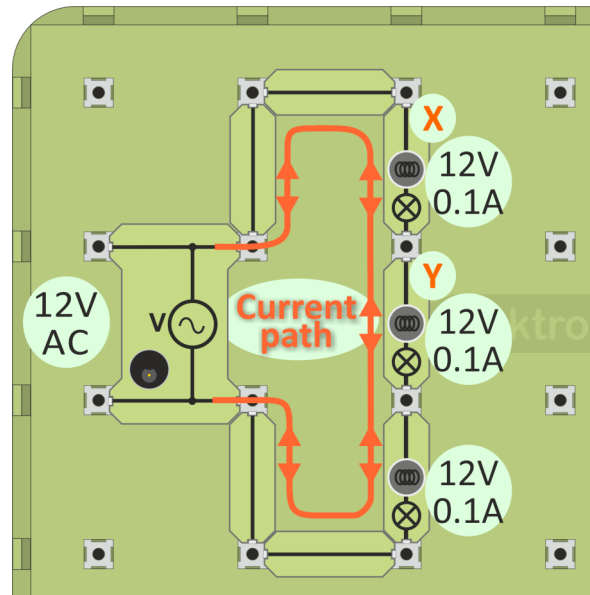

5. Now replace bulb 'Y' with a connecting link, as shown opposite.
6. Switch on the power supply.
7. What about the brightness of the two lamps? How does it compare with brightness of the lamps in first circuit?
8. What does this show about the current flowing in the circuit?
9. Unscrew one of the bulbs.  
Is the effect the same as before?

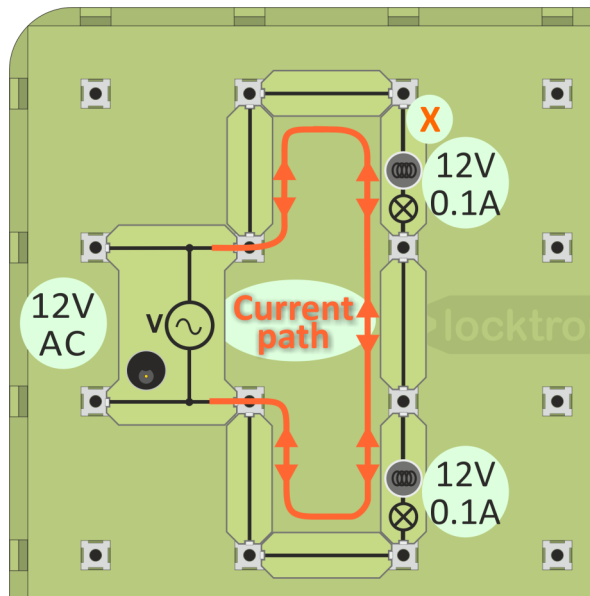

10. Write all your findings in the Student Handbook.

**If the lamps are of different brightness, look at**

**MES bulbs**

**and then come back to the next worksheet!**



# Connect in parallel



## Parallel:

- devices have their own separate 'branch-line';
- ends of a device connect to corresponding ends of all other devices;
- each device has its own path for the current through the connection.

Over to you

DC/AC

1. Build the layout shown below.  
This is a parallel circuit - each lamp is connected in its own 'branch-line'.
2. Connect the 12V power supply and switch on.

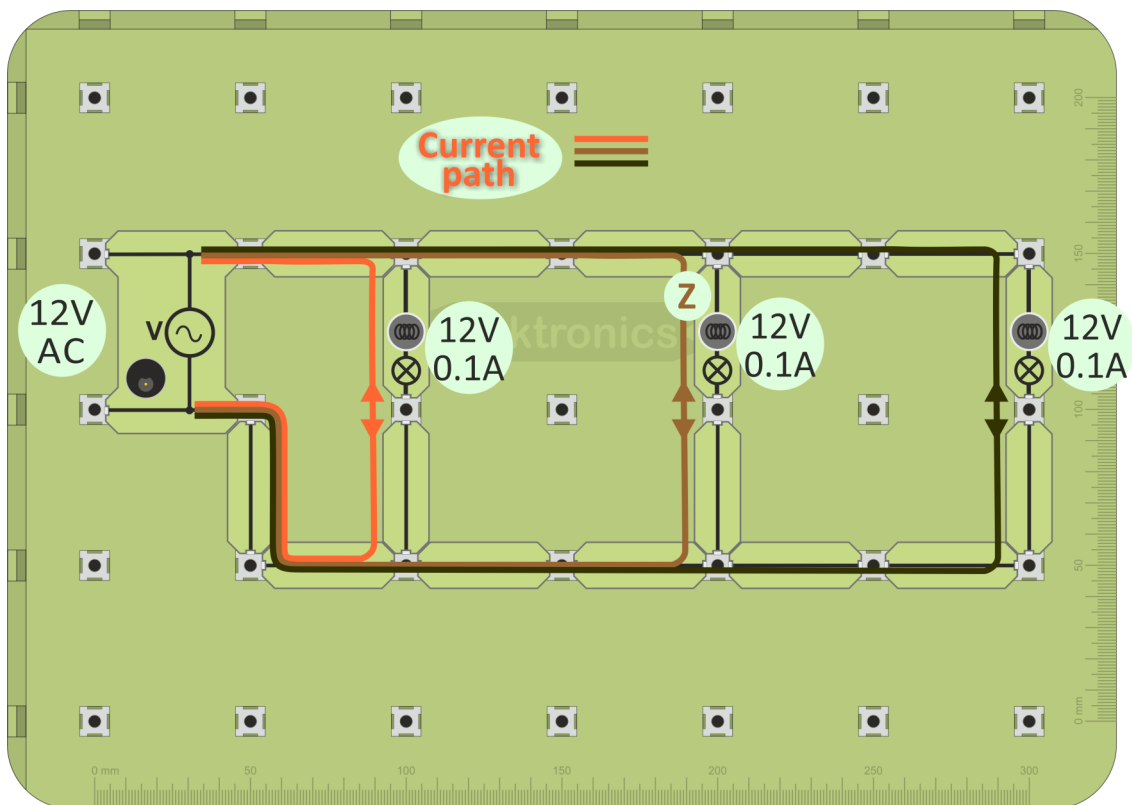

3. What do you notice about the brightness of the three lamps?
4. What happens if you unscrew one of the bulbs (bulb 'Z' for example)?
5. Notice how the current path differs from that for the series circuit!
6. Answer the questions in the Student Handout.

If the lamps are of different brightness, look at

MES bulbs

and then come back to the next worksheet!



# Series / parallel - 1

Often, some parts of a circuit are connected in series while other parts are in parallel. The rules you have observed in the previous circuits still apply.

Over to you **DC/AC**

1. Build the layout shown below.  
Which bulbs are in series and which in parallel?  
(Try to picture the current paths through the bulbs!)
2. Connect the 12V power supply and switch on.

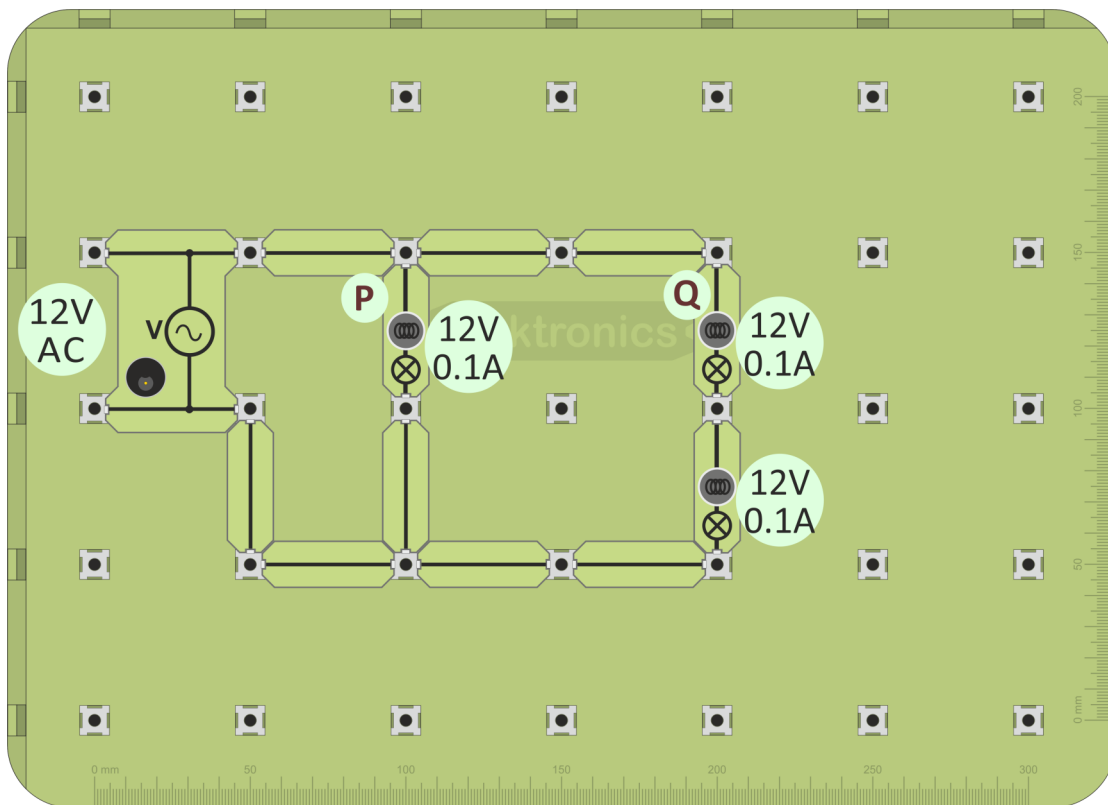

3. What do you notice about the brightness of the three lamps now?
4. What happens if you unscrew:
  - bulb 'P';
  - bulb 'Q' ?
5. Can you explain these differences?
6. Answer the questions in the Student Handbook.

Here is another circuit with a mixture of series and parallel connections.

- Decide where the series and parallel connections are. (Once again, picture the current paths!)

Over to you **DC/AC** you were right!

- Predict which bulb will be the brightest and then check to see if

1. Build the layout shown below.
2. Connect the 12V power supply and switch on.

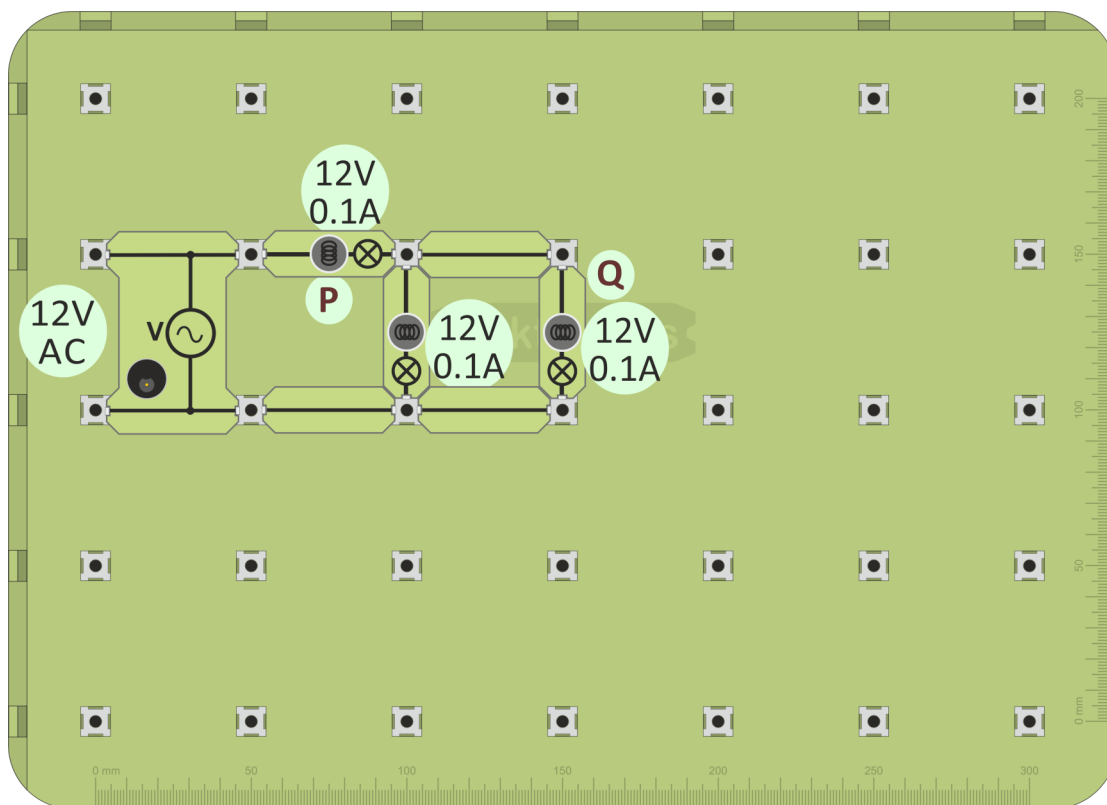

3. Compare the brightness of the three lamps? Were you right?
4. Now what happens if you unscrew:
  - bulb 'P';
  - bulb 'Q' ?
5. Try to explain these differences?
6. Answer the questions in the Student Handbook.





- MES bulbs are mass-produced to reduce cost.
- As a result, they are not quite identical:

They may have:

- different filament lengths;
- different filament diameters;
- different heat losses.

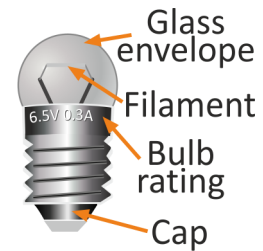

Given identical conditions, they will not give the same brightness.

You've been directed to this worksheet because the lamps in your circuit are not the same brightness.

There are two possible reasons for this:

- the bulbs are not quite identical;
- different currents flow through them.



Try the following test:

- swap the lamps round.

- If the pattern of brightness is the same as before, then the currents are different.
- If the brightest bulb is still the brightest, then the bulbs are different.

What does your test show?



In domestic lighting, it is important that lamps operate independently especially when one bulb ‘blows’. Hence they are connected in parallel, as the diagram shows.

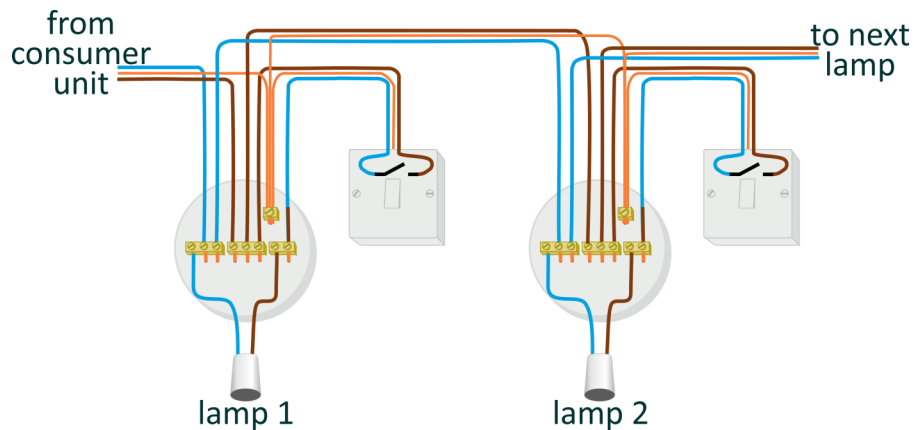

Controls, like fuses, switches and thermostats, must be able to ‘break’ the circuit and stop current flow to the load device, such as a heater. As a result, they are connected in series with the load.

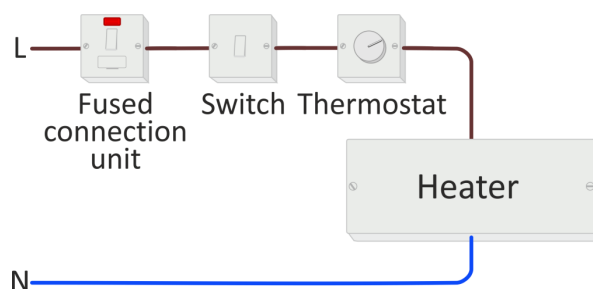

# Staircase circuit - 1

Here is a common circuit - a two-way switching circuit used to operate a light using either switch **A** or switch **B**. The light may be at the top of a staircase, with one switch at the bottom of the stairs and the other at the top. It uses two changeover switches for **A** and **B**. These are sometimes called 'single-pole-double throw' or SPDT switches and are connected by two

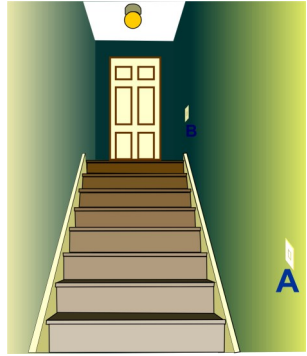

wires,- this method is sometimes called '2-wire control'.  
**Over to you** **DC/AC** -wire control'.

1. Build the layout shown below, using two 'changeover' switches, 'A' and 'B'.
2. Connect the 12V power supply and switch on.

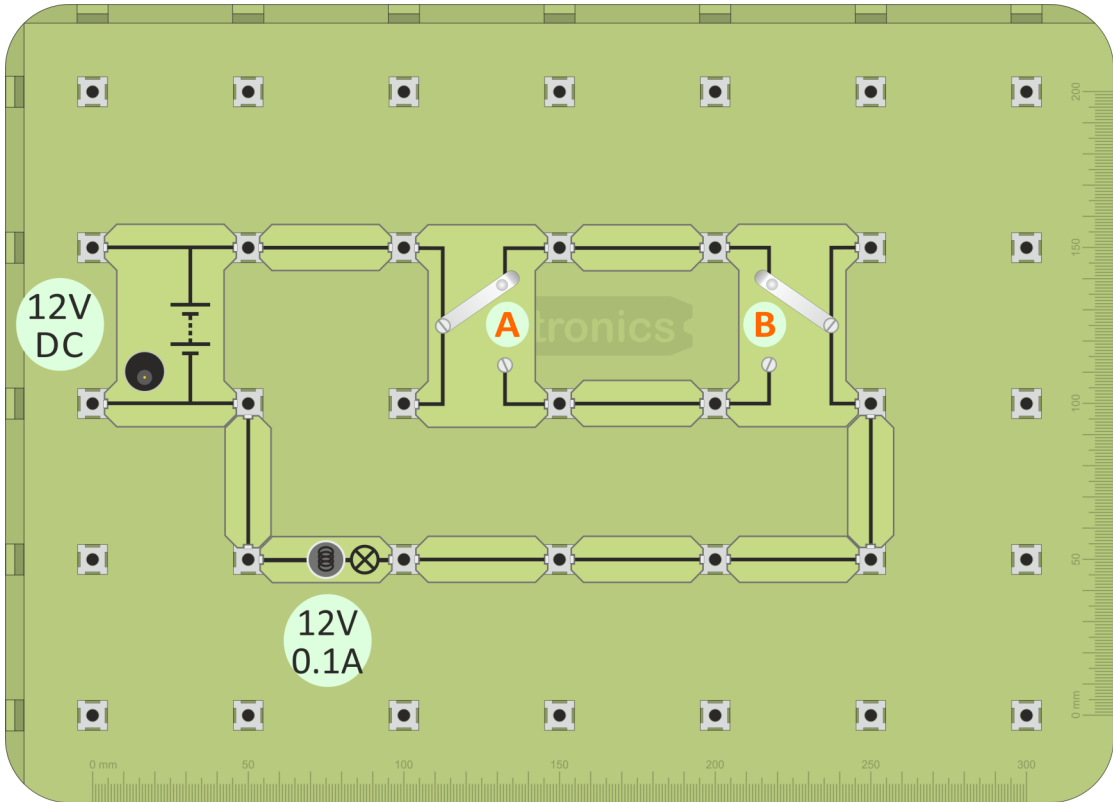

3. Move switch **A** into the other position. What happens?
4. Now move switch **B** into the other position. What happens?  
 You should be able to switch the lamp on an off using either switch.
5. For both of these, trace out the current paths.
6. Complete the diagram in the Student Handbook by adding the current path for the arrangement shown there.

# Staircase circuit - 2



The circuit uses two changeover switches like the one shown. Each has three terminals, **C** (for **C**ommon), **L1** and **L2**.

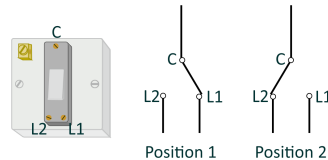

Operating the switch connects **C** to either **L1** or **L2**.

The '2-wire control' system is shown in the next diagram.

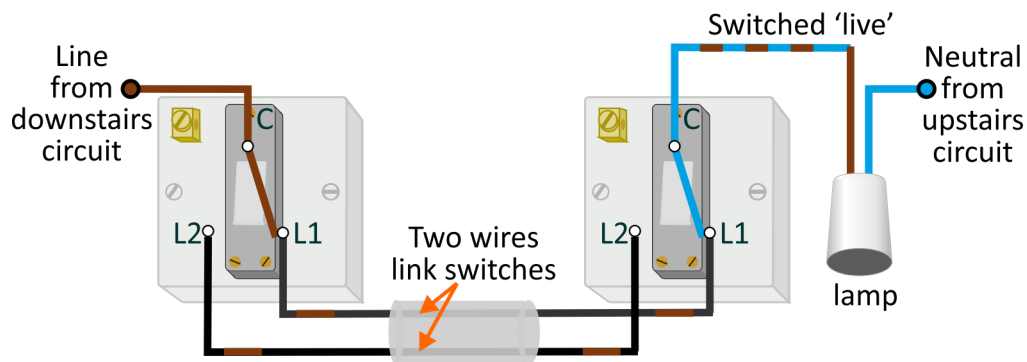

It works **but** there may be safety issues!

- The circuit may take its line connection from one circuit (e.g. downstairs) and its neutral from another (e.g. upstairs.) An electrician working on it might switch off the upstairs lighting circuit and think that the system is safe to work on. However, parts may still be 'live' because the downstairs circuit is still switched on.
- An RCD monitoring the downstairs circuit may trip unnecessarily because line and neutral currents downstairs may be different. Similarly, an RCD looking after the upstairs circuit may be unreliable.  
(RCDs are investigated in a few pages time.)

## Over to you **DC/AC**

The next layout demonstrates the safer '3-wire control' system. This time, both line and neutral connections can be taken from the same circuit, either downstairs or upstairs.

The potential problems created by the '2-wire control' system are avoided.

1. Build the layout shown below, again using two 'changeover' switches.
2. Connect the 12V power supply and switch on.

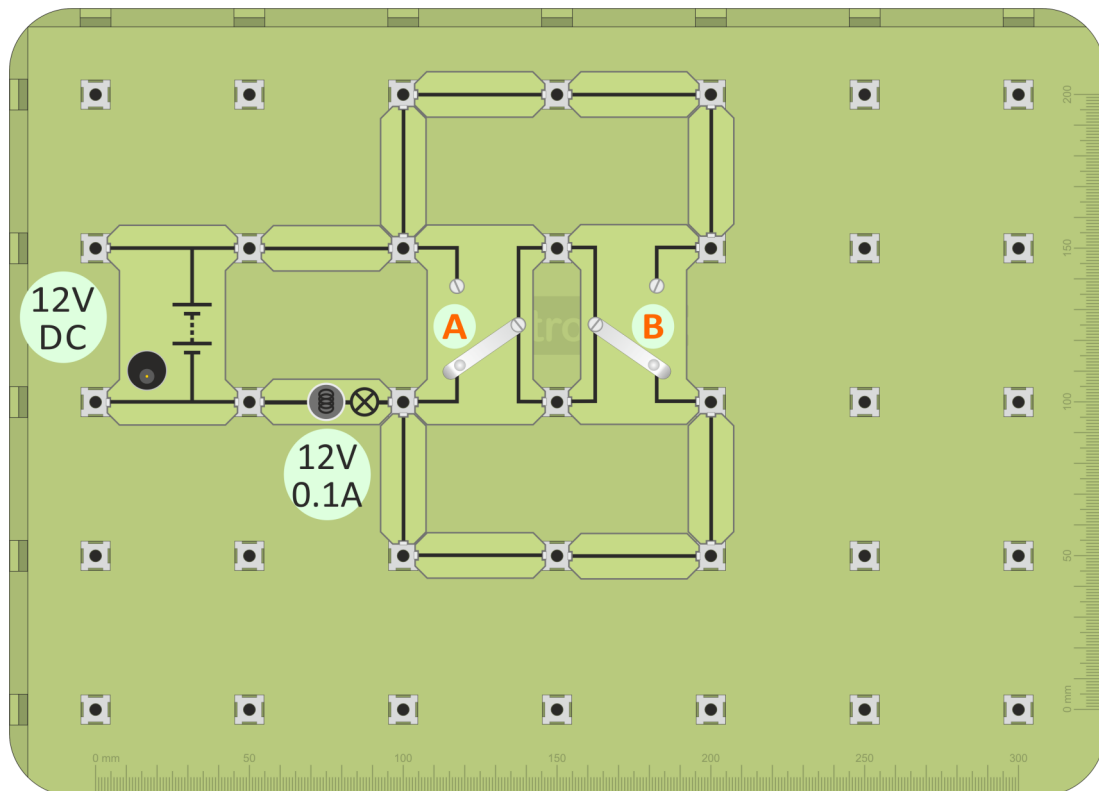

3. As before, you should be able to switch the lamp on and off using either switch.
4. Complete the diagrams in the Student Handbook.

# Staircase circuit - 4



The next diagram shows a practical form of the '3-wire control' system, so-called because three wires link the two switches together.

For clarity:

- the earth connections are shown as dotted lines;
- the wire connecting the two common connections is shown in purple.

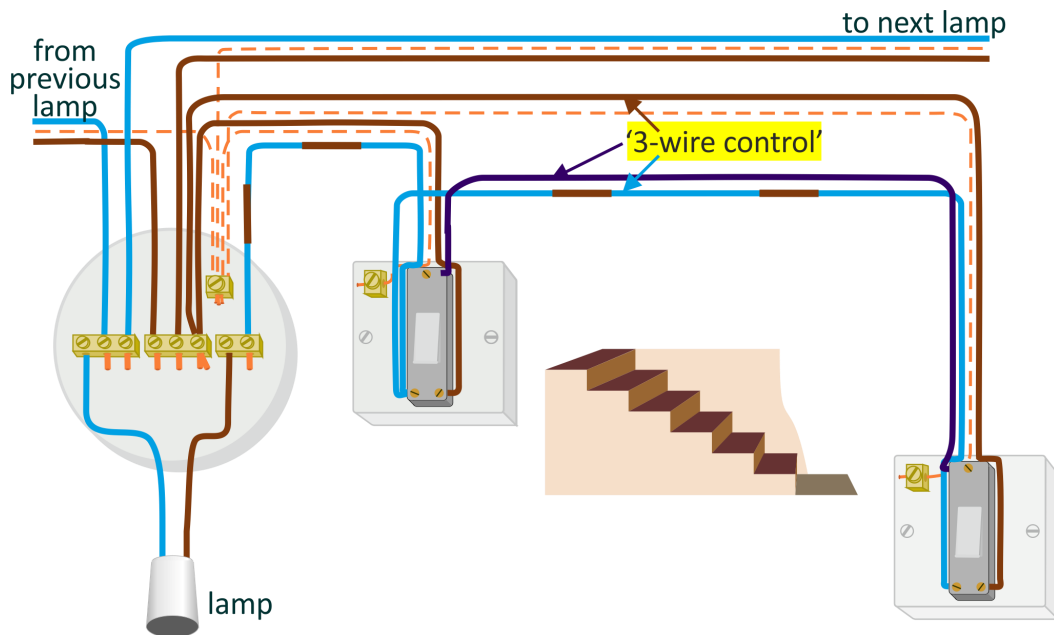

Points to note:

- **L1** terminals are connected together and to the incoming 'line' connection;
- **L2** terminals connected to each other and to the 'switched wire';
- **C** terminals are connected together.

## Challenge

Starting with the 'live' connection, (brown) from the previous lamp, trace out the circuit.

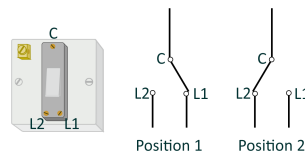

Notice that:

- with the left-hand switch is in position 1, **L1** is connected to **C**, making it 'live';
- the **C** terminal in the other switch is connected to it, and so is also 'live';
- with the right-hand switch is in position 2, **L2** is connected to **C** and so is 'live';
- this makes the brown wire to the lamp 'live' and so the lamp lights.

Then, in the same way, trace out the circuit with the switches in other positions.



## 3-way control - 1

This is a modification of the previous circuit.

By adding a third switch - an intermediate switch, (also called a reversing or a double-pole-double-throw (DPDT) switch), the lamp can be controlled by three switches, **A** or **B** or **C**.

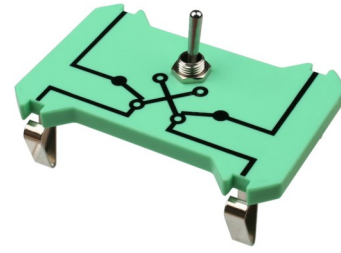

### Over to you DC/AC

1. Build the layout shown below, using two 'changeover' switches, 'A' and 'B' and an intermediate switch 'C' (or modify the previous circuit by adding 'C' .)
2. Connect the 12V power supply and switch on.  
(The layout shows the AC supply, reflecting the domestic electricity supply.)

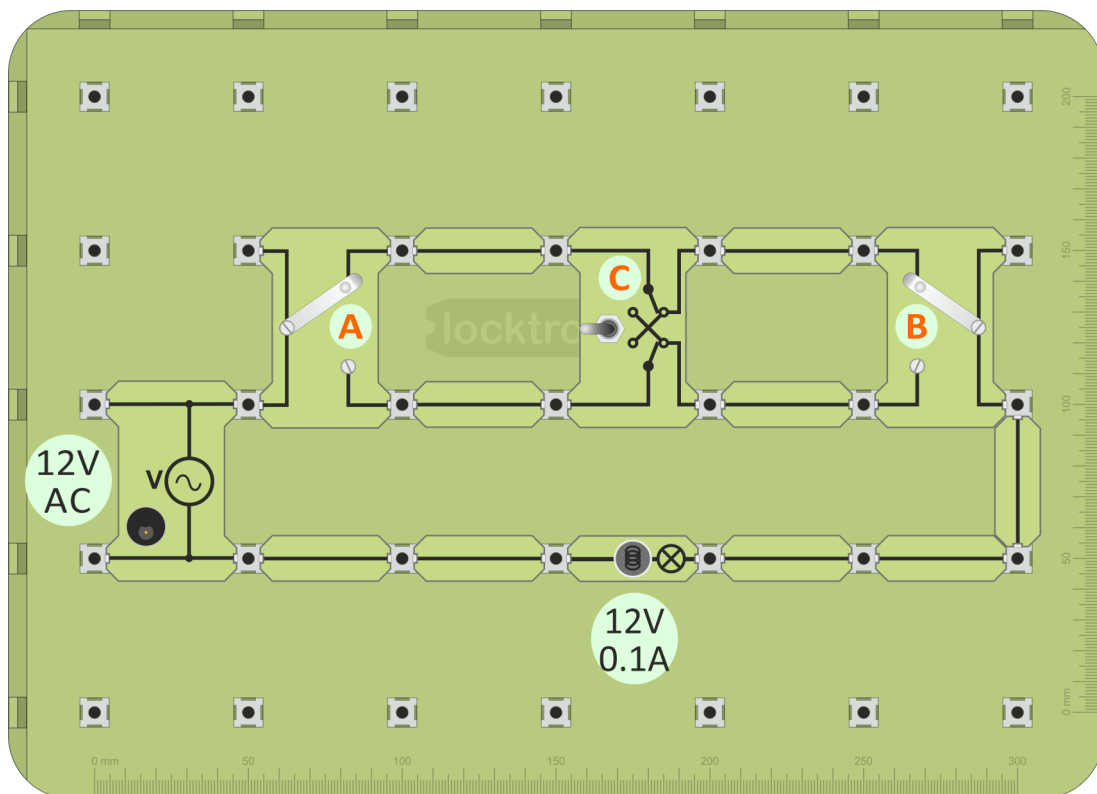

3. Check that the lamp can be controlled by all the switches.
4. For all eight combinations of switch positions, trace out the current paths.
5. Complete the diagram in the Student Handbook by adding the current path for the arrangement shown there.

This is another '2-wire control system' and suffers from the same potential problems as the 2-way (staircase) system.

# 3-way control - 2

The third switch is known (in the UK) as an intermediate switch.

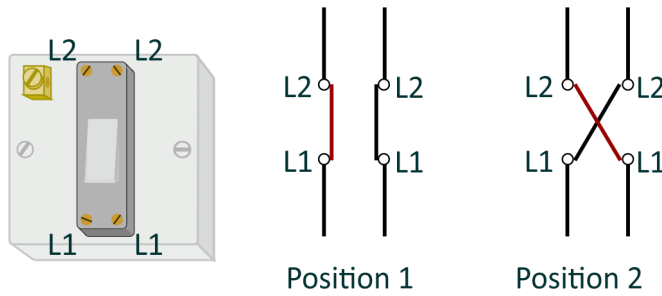

It has four terminals, two labelled **L1** and two labelled **L2**.  
Operating it makes the connections shown above.

The '3-wire control' version of the three-way switching circuit is shown below.

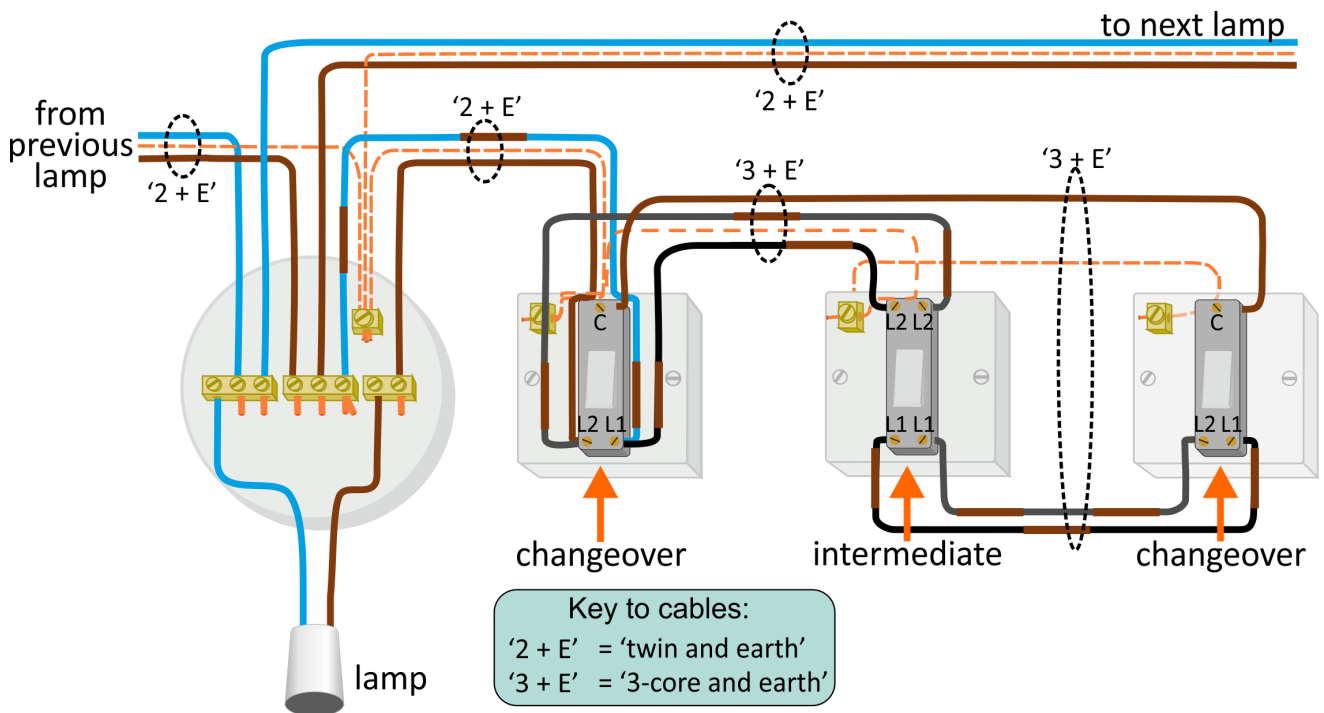

Compare this circuit with the one you just built using 'Locktronics'.

# Measuring voltage - 1



The picture shows one form of multimeter. It has a wide range of uses - varies from model to model - but usually includes measuring AC and DC voltage and current

When using a multimeter, before you switch it on:

- take care to plug the probes into the correct sockets;
- select the correct range.

(‘Auto-ranging’ versions select the best range automatically.)

## Voltage:

- is a measure of the force pushing the electrons around the circuit;
- measures energy lost or gained as an electron moves through part of a circuit
- is measured with a voltmeter connected in parallel with the component.

The circuit symbol for a voltmeter is shown in the diagram.

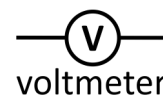

## Using a multimeter to measure voltage:

Multimeters can measure both AC and DC.

The following symbols distinguish between them:

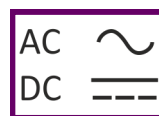

- Plug one wire into the black ‘COM’ socket.
- Plug another into the red ‘V’ socket.
- Select the 20V DC range by turning the dial to the ‘20’ mark next to the ‘V ’ symbol.

(It is good practice to set the meter on a range that is much higher than the reading you are expecting.

Then refine it by choosing a lower range to suit the voltage you find.)

- Plug the wires into the sockets at the ends of the component under investigation.
- Switch on the multimeter when you are ready to take a reading.
- A ‘-’ sign in front of the reading means that the meter wires are connected the wrong way round. Swap them over to get rid of it!



## Measuring voltage - 2

Over to you **DC/AC**

1. Build the layout shown below - a series circuit with only one route around it.
2. Connect the power supply, set to 12V, and switch on.

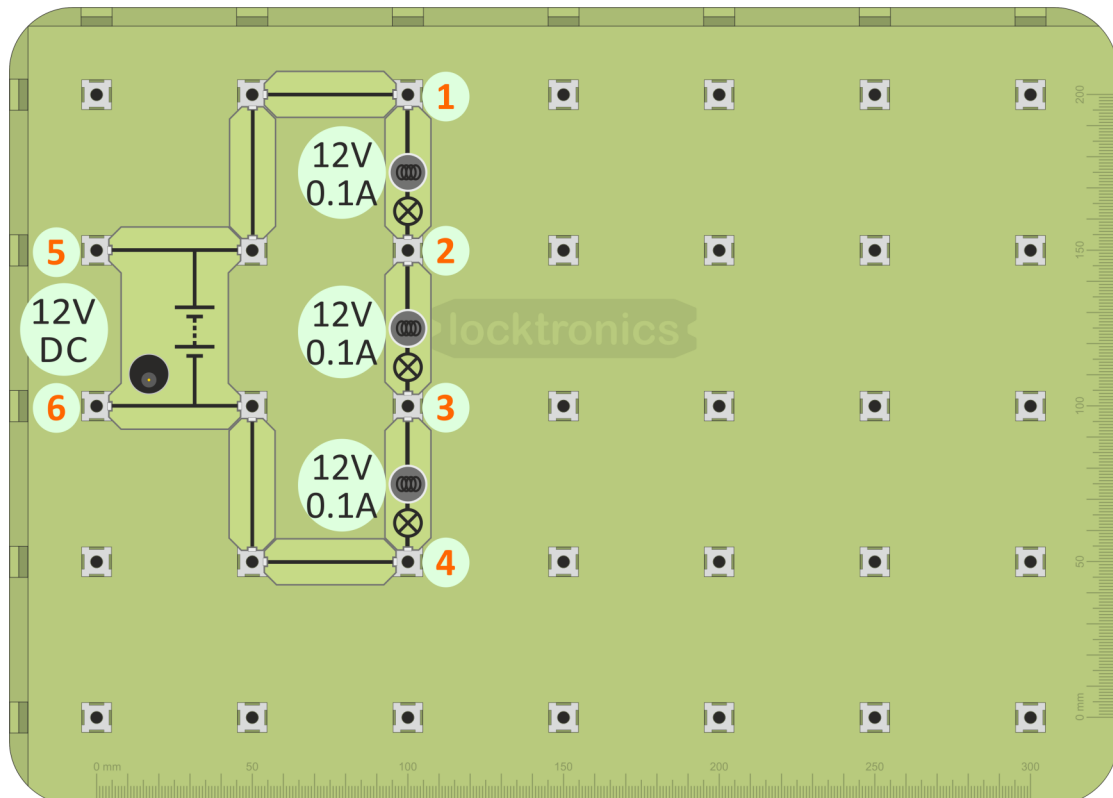

3. Set up the multimeter to read voltages up to 20V DC - see the previous page.
4. Measure the voltage across the top bulb, by plugging the multimeter leads into posts '1' and '2'.
5. Next, measure the voltage across the middle bulb, using posts '2' and '3'.
6. Then measure the voltage across the third bulb, using posts '3' and '4'.
7. Finally, measure the supply voltage, using posts '5' and '6'.
8. Add together the voltages across the three bulbs and compare it with the supply voltage. What do you notice?
9. Enter all your results into the table in the Student Handbook and answer the question.

1. Build the layout shown below - this time a parallel circuit.
2. Connect the power supply, set to 12V, and switch on.

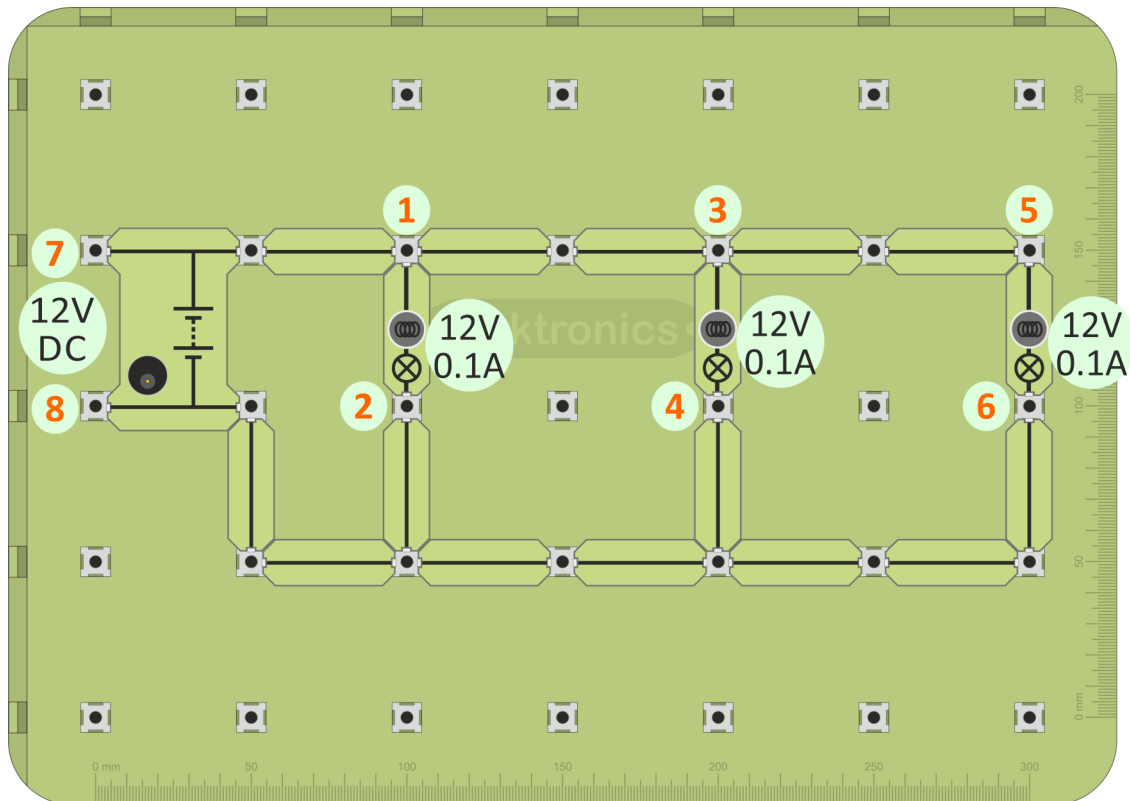

3. Set up the multimeter to read voltages up to 20V DC.
4. Measure the voltage across the first bulb, by plugging the multimeter leads into posts '1' and '2'.
5. Next, measure the voltage across the middle bulb, using posts '3' and '4'.
6. Then measure the voltage across the third bulb, using posts '5' and '6'.
7. Finally, measure the supply voltage, using posts '7' and '8'.
8. Look at the voltages across the three bulbs and across the supply voltage. What do you notice?
9. Enter all your results into the table in the Student Handbook and answer the question.

## Measuring voltage - 4

Now we return to one of the circuits that have both series and parallel connections to see why the bulbs have the brightness we observed earlier.

Over to you **DC/AC**

1. Build the layout shown below and switch on the power supply.

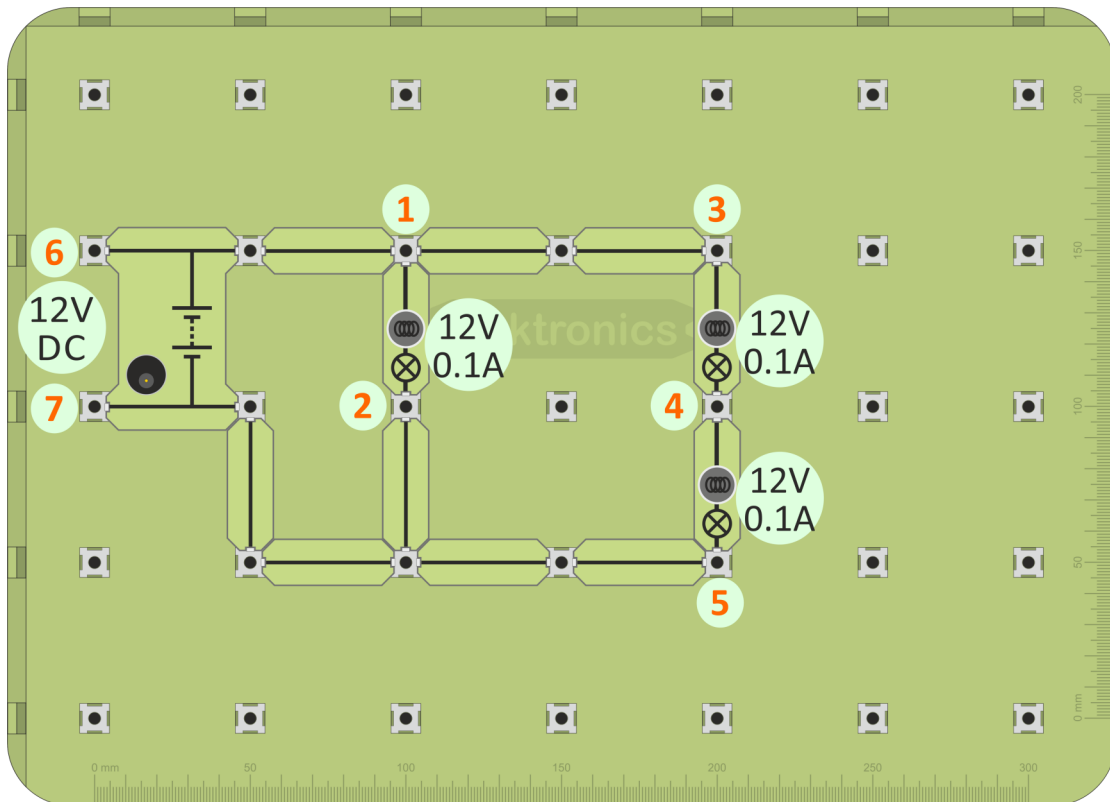

2. Measure the voltage across the first bulb, using posts '1' and '2'.
3. Next, measure the voltages across the other two bulbs, using posts '3' and '4' and then '4' and '5'.
4. Finally, measure the supply voltage, using posts '6' and '7'.
5. Look at the voltages across the bulbs. Does this explain the different brightness?
6. What do you notice about the supply voltage and the voltages across the bulbs?
7. Enter all your results into the table in the Student Handbook and answer the question.



Investigate the other mixed circuit which you built earlier.





When using a multimeter to measure current, plug the probes into the '**A**' and '**COM**' sockets, or equivalents.

Then select the correct range, either from the '**A~**' section, for AC current or the '**A**  ' section, for DC current.

Finally, switch on.

## Current:

- measures the number of electrons passing any point in the circuit each second;
- measures the rate of flow of electrical charge in the circuit;
- is measured with an ammeter connected in series with the component.

The circuit symbol for a ammeter is shown in the diagram.

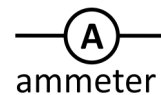

ammeter

## Using a multimeter to measure current:

- Plug one wire into the black '**COM**' socket.
- Plug another into the red '**mA**' socket.
- Select the 200mA DC range by turning the dial to the '**200m**' mark next to the '**A**  ' symbol.  
(Again, it is best to set the meter on a higher range to begin with. Then choose a lower range to suit the current you find.)
- Break the circuit where you want to measure the current, by removing a link, and then plug the two multimeter wires in its place.
- Switch on the multimeter when you are ready to take a reading.
- A possible problem - The ammeter range is protected by a fuse located inside the body of the multimeter. This may have 'blown', in which case the ammeter will not work. Report any problems to your instructor so that it can be checked.

## Measuring current - 2

Over to you

DC

1. Build the layout shown below - a series circuit of three lamps but this time spread out to allow easy insertion of the ammeter when needed.
2. Connect the DC power supply, set to 12V, and switch on.

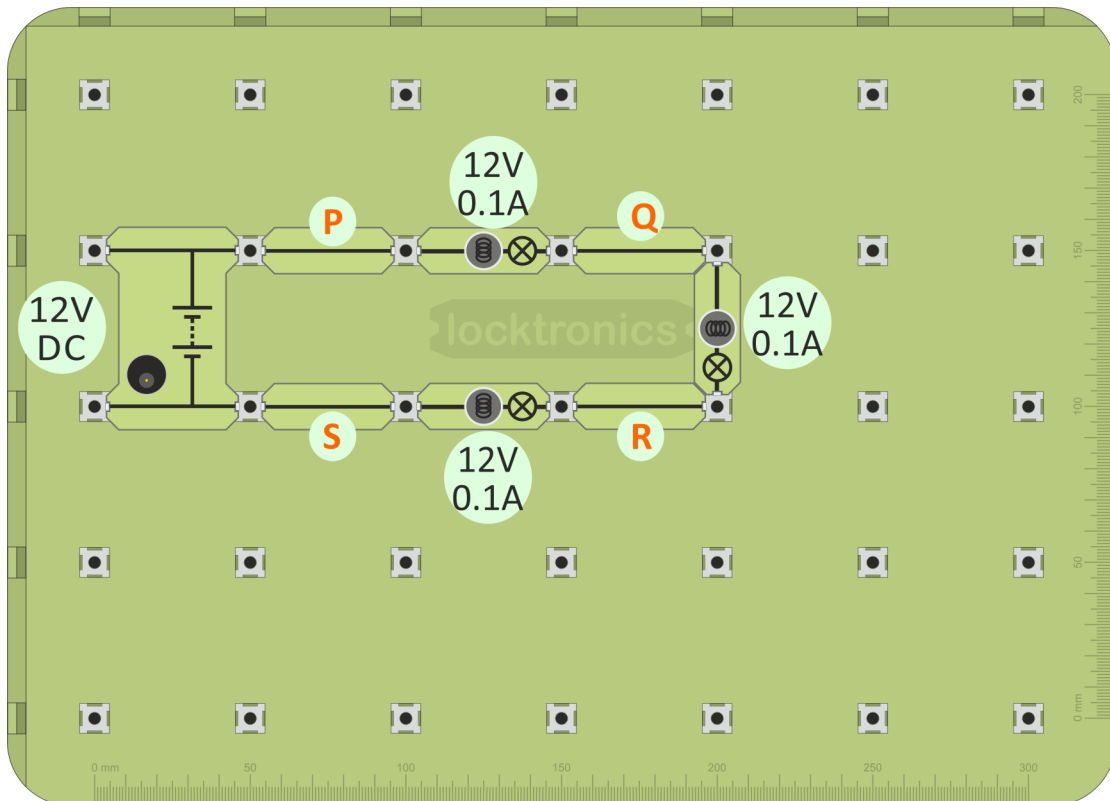

3. Set up the multimeter to read currents up to 200mA DC - see the previous page.
4. Measure the current at point 'P', by removing the connecting link and plugging the multimeter leads into the posts at either end of it.
5. In the same way, measure the current at points 'Q', 'R' and 'S'.

You could say that the current at 'P' is the current delivered by the power supply, or the current flowing into the first bulb. Equally, the current at 'Q' is that leaving the first bulb, or entering the second one - and so on.

6. What do you notice about all the current readings?
7. Enter all your results into the table in the Student Handbook and answer the question.

## Measuring current - 3

Over to you **DC**

1. Build the layout shown below - a parallel circuit of three lamps, again spread out to allow easy insertion of the ammeter when needed.
2. Connect the DC power supply, set to 12V, and switch on.

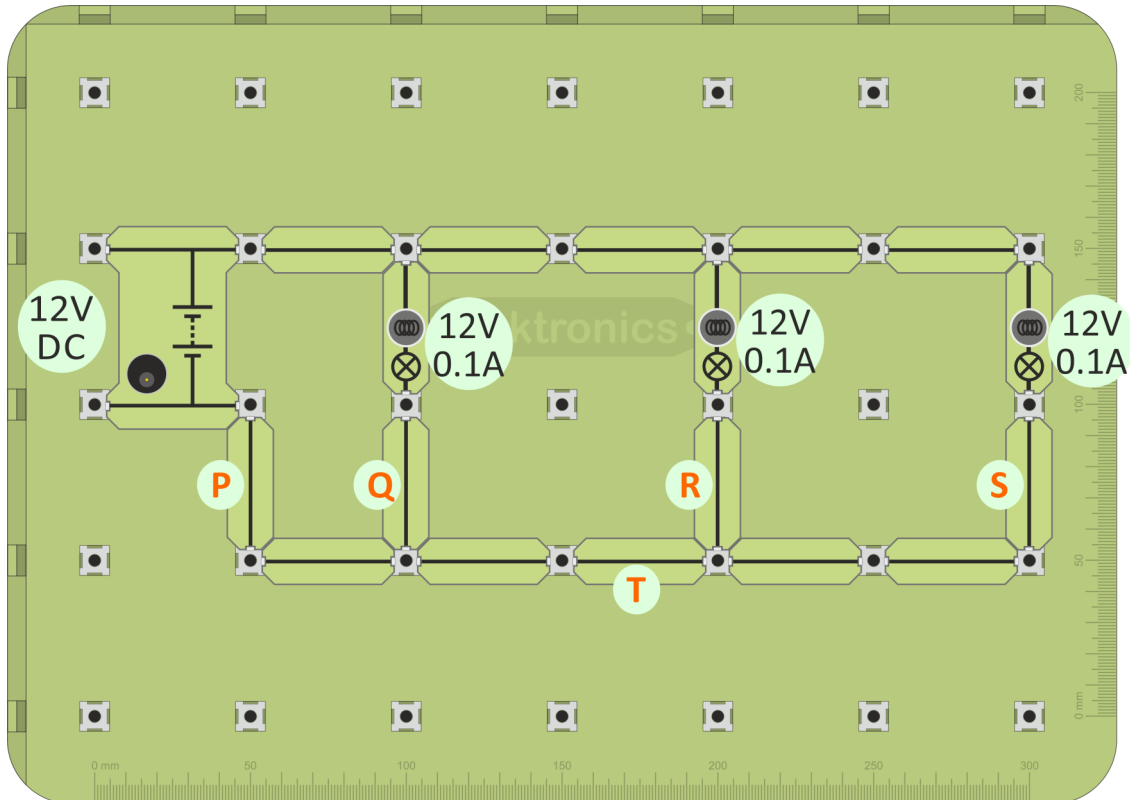

3. Set up the multimeter to read currents up to 200mA DC as before.
4. Measure the current at points 'P', 'Q', 'R' and 'S', by removing appropriate connecting links.
5. Enter your results into the table in the Student Handbook and answer the question.

### Challenge

6. Use your results to estimate the current flowing at point 'T'.
7. Now measure it. Were you correct?

Write its value in the Student Handbook.

## Measuring current - 4

Now we look at the currents flowing in one of the circuits that have both series and parallel connections.

Over to you

DC

1. Build the layout shown below.
2. Connect the DC power supply, set to 12V, and switch on.

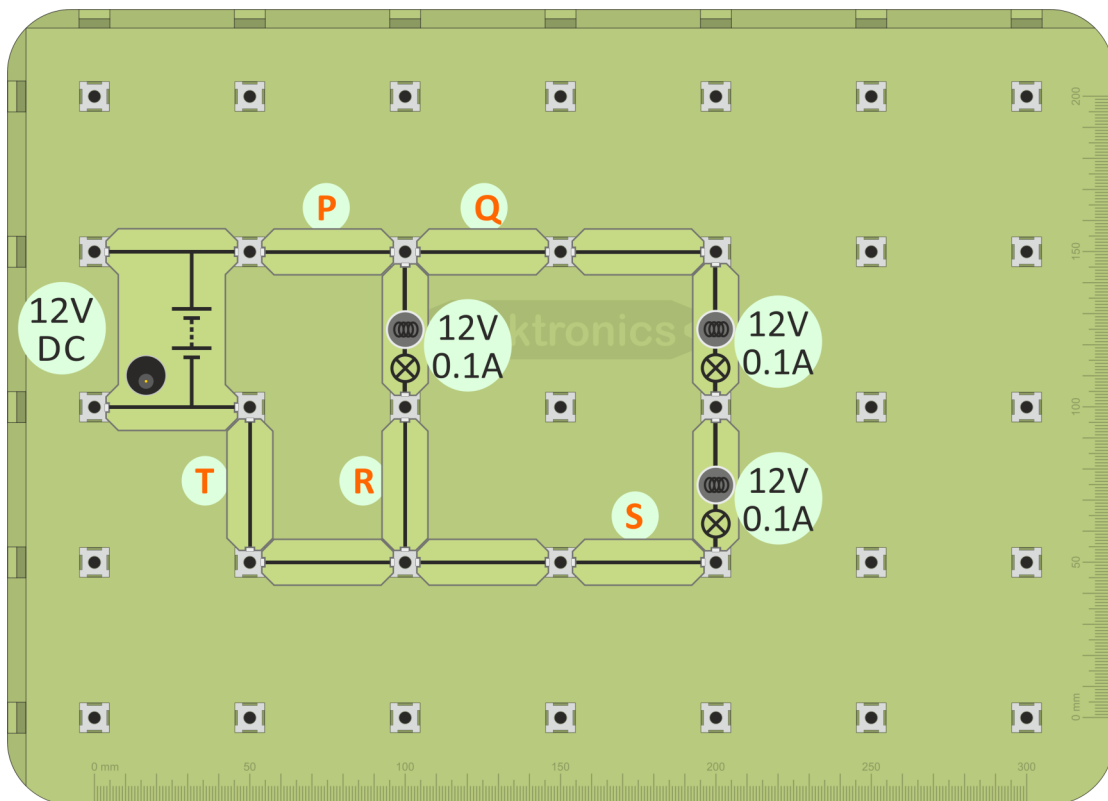

3. Measure the current at points 'P', 'Q', 'R', 'S' and 'T'.
4. Enter all your results into the Student Handbook.
5. Explain why the current readings at points 'P' and 'T' are equal.
6. Explain why the current readings at points 'Q' and 'S' are equal. What does this imply for the brightness of the two bulbs between these points?
7. Compare these readings with the current at point 'R'. What does this mean for the brightness of the nearby bulbs?

Challenge

Carry out a similar investigation on the other mixed circuit, built earlier.

# Kirchhoff's voltage law

**The voltage law** - the sum of voltages around any loop in the circuit equals the power supply voltage in that loop.

**The implications** - In the circuit that follows there are a number of 'loops'.

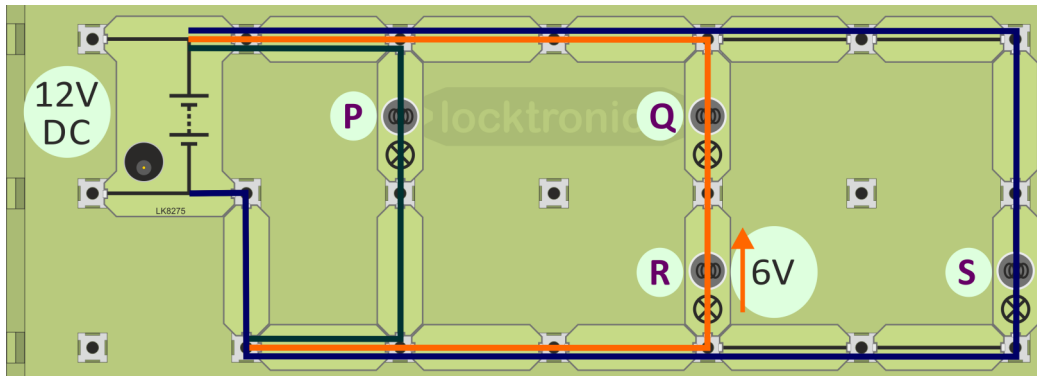

In the **green** loop:

- total power supply voltage in the loop = 12V;
- only one bulb in the loop, so voltage across bulb **P** = 12V.

In the **blue** loop:

- total power supply voltage in the loop = 12V;
- only one bulb in the loop, so voltage across bulb **S** = 12V.

In the **orange** loop:

- total power supply voltage in the loop = 12V;
- two bulbs in the loop, so voltages across them must add up to 12V;
- voltage across bulb **R** = 6V, (we are told);
- so voltage across **Q** must be  $12 - 6 = 6V$ .



If you are unsure about these results, build the circuit and check them!

Answer the questions in the Student Handbook.

**The current law** - the total current flowing into any junction in the circuit is equal to the total current flowing out of that junction.

**The implications** - In the circuit that follows there are a number of 'junctions'.

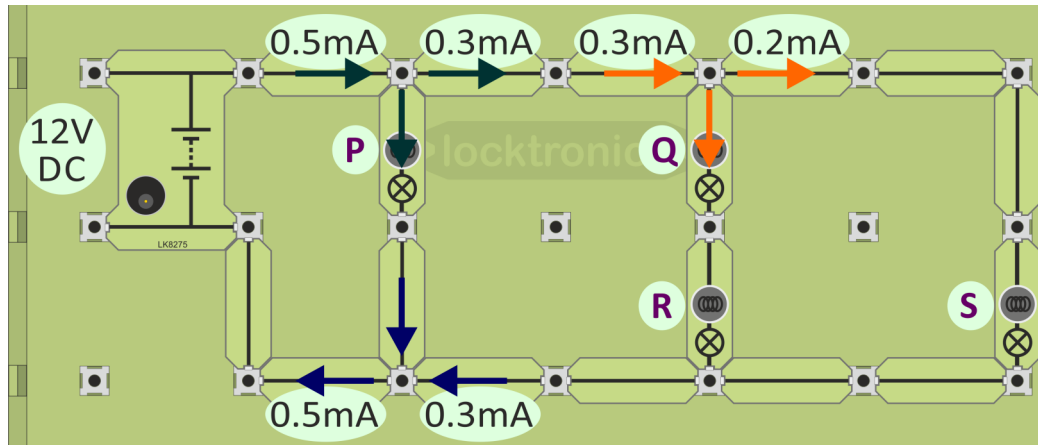

At the **green arrow** junction:

- total current flowing into junction =  $0.5\text{mA}$ ;
- total current flowing out of junction =  $0.3\text{mA}$  + current through lamp **P**;
- so current through bulb **P** =  $0.2\text{mA}$ .

At the **orange arrow** junction:

- total current flowing into junction =  $0.3\text{mA}$ ;
- total current flowing out of junction =  $0.2\text{mA}$  + current through lamp **Q**;
- so current through lamp **Q** =  $0.1\text{mA}$ .

At the **blue arrow** junction:

- total current flowing into junction =  $0.3\text{mA}$  + current through lamp **P** =  $0.5\text{mA}$ ;
- so current flowing out of junction =  $0.5\text{mA}$ .

Lamps **Q** and **R** are in series, so the same current flows through them.

Hence, current through **R** =  $0.1\text{mA}$



If you are unsure about these results, build the circuit and check them!

Answer the questions in the Student Handbook.



# Resistance - 1



So far it has been on/off control of electric currents, using conductors or insulators. Now we want a more subtle control. Using a tap, we can change the flow of *water*. With *electricity*, we change the flow using a **resistor**.



Over to you

DC/AC

1. Create your resistor, using a short length of graphite (pencil lead) in the universal component carrier.
2. Build the layout shown below.
3. Connect the 12V power supply and switch on.

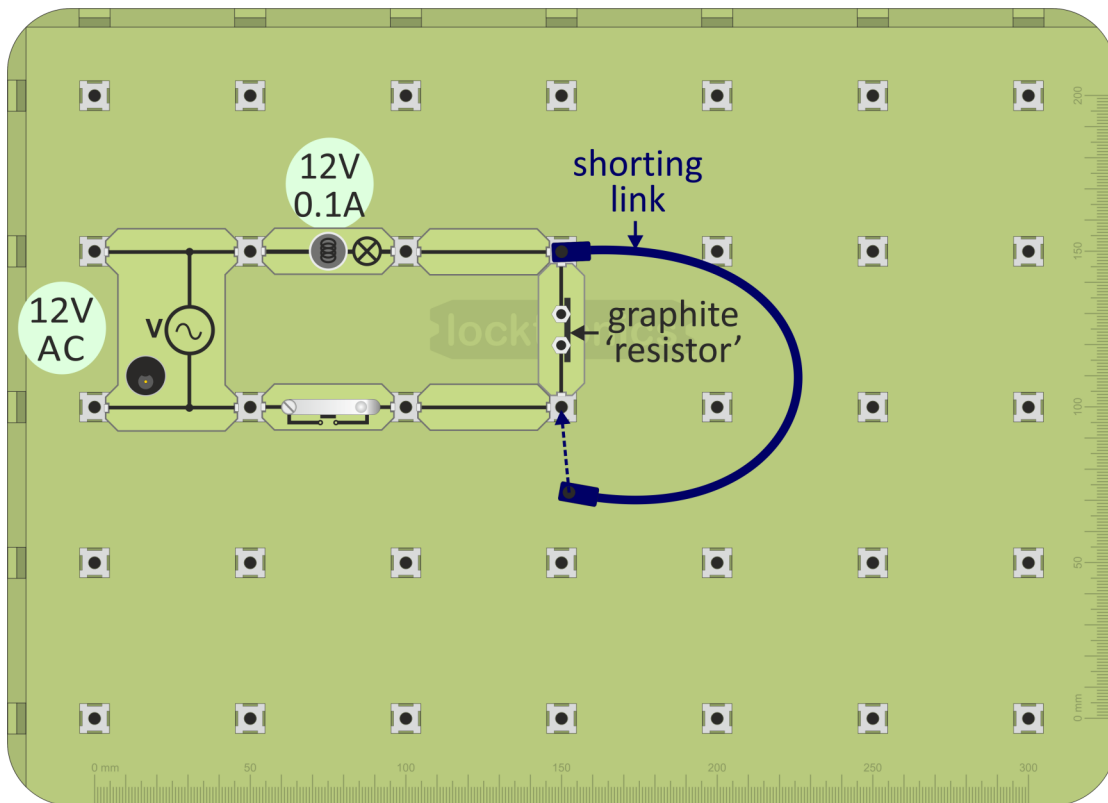
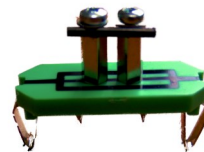

4. Close the switch and notice how bright the bulb looks. Remember – the brighter the bulb, the greater the current flowing.
5. Next, 'short-circuit' the resistor by joining both ends with a wire, as shown. What do you notice about the bulb? What does this tell you about the electric current when you add the resistor?

Now answer the questions in the Student Handbook!

# Resistance - 2



For electrons, adding resistance is like asking you to run in mud. It takes more energy!

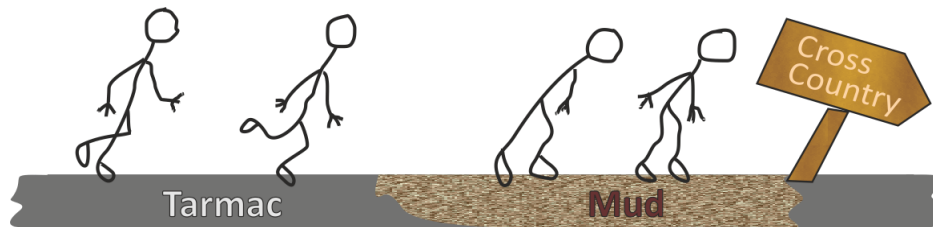

Commercially-made resistors often look like the one opposite. The colour of the stripes is significant, but that is for later!



## Over to you **DC/AC**

1. Build the layout shown below.
2. Connect the 12V power supply and switch on.

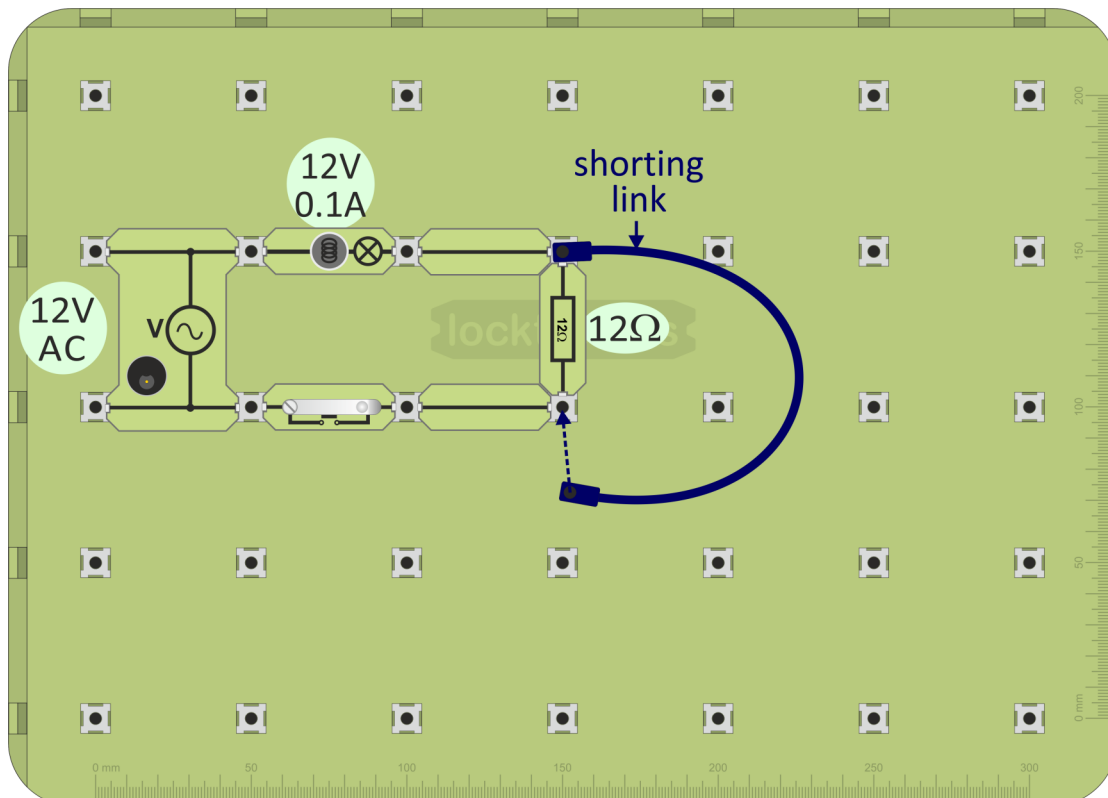

3. Close the switch and notice how bright the bulb looks.
4. Next, 'short-circuit' the resistor with the wire. What happens to the bulb? What does that tell you about the current?



## Ohm's law:

- relates the current, **I**, through a resistor, **R**, to the voltage, **V**, across it;
- results in the formula: **V = I x R** ( or **I = V / R**, or **R = V / I**), using either volts / amps / ohms or volts / milliamps / kilohms;
- applies only when the temperature of the conductor stays steady.

When devising a new test procedure, it's reassuring to start with a situation where you know the answer!

In this case, we are going to work out the resistance of a  $1\text{k}\Omega$  resistor!



1. Build the following layout, using multimeters for the voltmeter and ammeter.

Settings:

**voltmeter** - greater than 12V,      **ammeter** - around 20mA.

2. Set the power supply to 12V, connect it to the circuit and switch on.

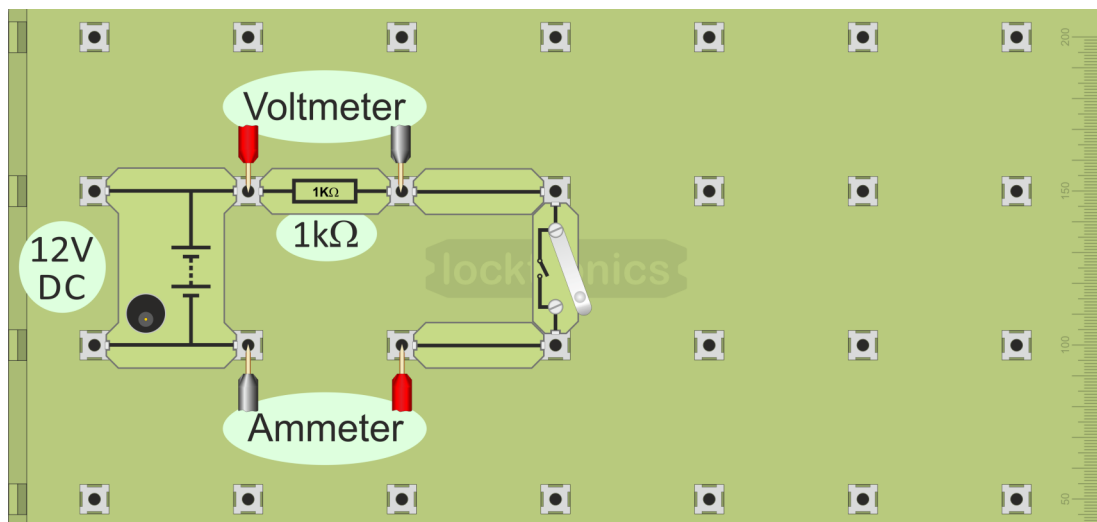

3. Close the switch.
4. Measure the voltage across the resistor and the current flowing through it.
5. Record the results in the Student Handbook and calculate the resistance of the resistor.
6. Repeat the process with the power supply voltage to 6V.
7. Replace the  $1\text{k}\Omega$  resistor with a 12V 0.1A lamp. In the same way, work out its

Now, take a look at what happens when we combine resistors together.

In the last activity, you worked out the resistance of a 12V 0.1A bulb, at 6V and 12V.

This activity uses two of these, first in series and then in parallel.

## Over to you **DC**

1. Build the layout shown below. The two lamps are in series.
2. Connect the 12V power supply and switch on.

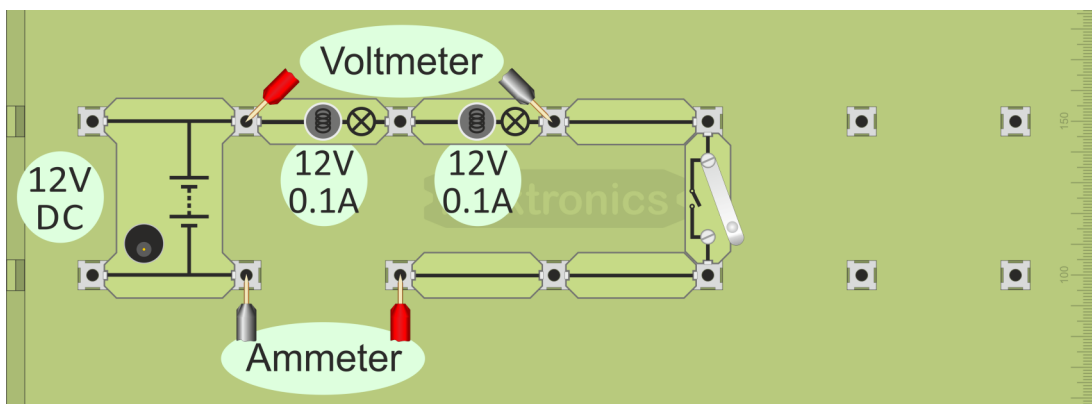

3. Close the switch.
4. Measure the voltage across the lamp combination and the current through it.
5. Record your readings in the Student Handbook and work out the resistance of the two lamps in series.
6. Answer the questions about your results.

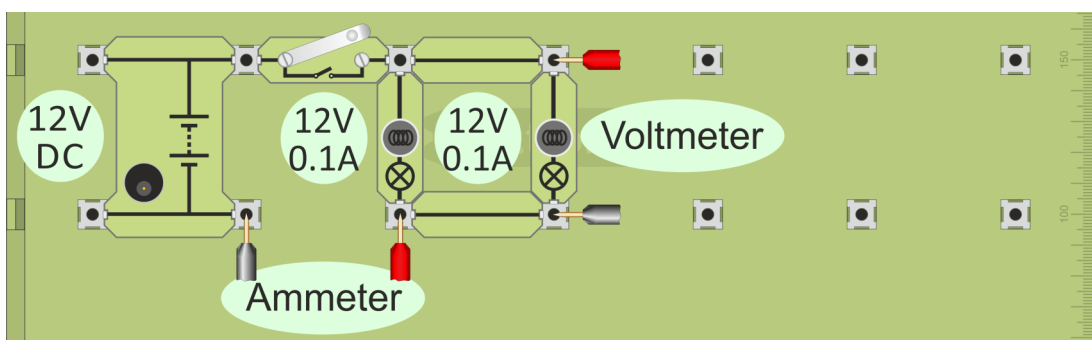

7. Modify the circuit, as shown, so that the lamps are connected in parallel.
8. Measure the voltage across the combination and the current through it.
9. Once again, record your readings in the Student Handbook and work out the resistance of the lamps in parallel. Answer the questions about your results.



**When using a multimeter to measure resistance, the component must be removed from the circuit first!**

As before, before you switch on:

- take care to plug the probes into the correct sockets, the ' $\Omega$ ' and '**COM**' sockets;
- select the correct range.

## Resistance:

- is a hindrance to the flow of electrons around the circuit;
- removes energy from each electron as it moves through the resistor;
- converts this energy into heat;
- is measured in units called 'ohms' (symbol - ' $\Omega$ ') or kilohms ( $k\Omega$ ), by an ohmmeter. (1 kilohm = 1 000 ohms.)

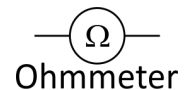

## Using a multimeter to measure resistance:

- Plug one wire into the black '**COM**' socket.
- Plug another into the red ' $\Omega$ ' socket.
- Turn the dial to select a resistance range, such as 200k $\Omega$ .  
(As before, it is good practice to set the meter on a range higher than the reading you are expecting and then refine it to a lower range.)
- Make sure that the component under investigation is not connected to any other.
- Plug the wires into the sockets at the ends of the component.
- Switch on the multimeter when you are ready to take a reading.

## Measuring resistance - 2

### Over to you

The first task is to measure the resistance of the  $12\Omega$  carrier.

Although we know what answer to expect, the value displayed is unlikely to be exactly  $12\Omega$  and it will show that the multimeter is working!

1. Set the multimeter on the  $200\Omega$  range.
2. Make sure that the probes are plugged into the ' $\Omega$ ' and '**COM**' sockets.
3. Press the tips of the probes against the metal clips on the carrier, as shown in the diagram.
4. Read the value of resistance shown on the multimeter.
5. Record this value in the Student Handbook.

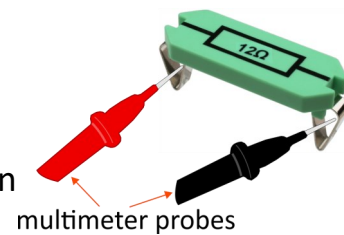

(The measurement is unlikely to be exactly  $12\Omega$ !

The quandary - is there some inaccuracy in the resistor, or is the multimeter not totally accurate?

(The answer is probably a little bit of both!)

Next, do the same for the home made resistor.

We expect this to have quite a low resistance, judging by its effect on the bulb earlier.

Nevertheless, keep the meter on the  $200\Omega$  range, at least to begin with.

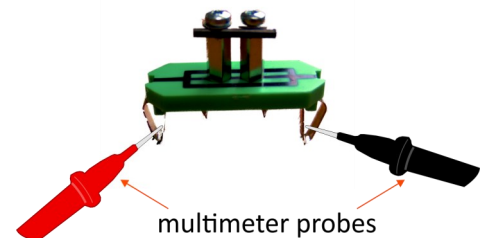

Record its value in the Student Handbook as well.

Finally, use the same procedure to measure the resistance of the 12V 0.1A bulb.

Again, record its value in the Student Handbook.

Obviously, this measurement is done with the filament at room temperature.

In the 'Ohm's law - 1' activity, you measured its resistance when glowing dimly (6V) and brightly (12V). The difference between the resistance measurements is caused by temperature.

Answer the question in the Student Handbook.

# Resistivity - 1



The resistance of a wire depends on three factors - its **length**, **cross-sectional area** and the **resistivity** of the material it is made from. It is measured in units called  $\Omega$  m (ohm metres).

“Which is heavier, a ton of lead or a ton of feathers?”  
Silly question - both weigh the same!



The next question is just as bad -

“Which has a bigger resistance, a copper  $1k\Omega$  resistor or a nichrome  $1k\Omega$  resistor?”



(**Nichrome** - nickel-chromium alloy designed for use in resistors.)

Both are the same -  $1k\Omega$ , but the copper one would be enormous by comparison.

Why?

The answer - **Resistivity**

(how strongly a material opposes the flow of electric current through it)!

Nichrome’s resistivity is 60 times that of copper!

All other things being equal, the copper resistor would have to be 60 times larger!

## Picture it:

Flow of electricity is often likened to flow of water - the wider the pipe, the greater the flow of water, the fatter the wire, the greater the current etc.

To picture resistivity, think of water flowing down an empty pipe and compare it with water flowing down the same sized pipe full of sand.

The first = copper; the sec-

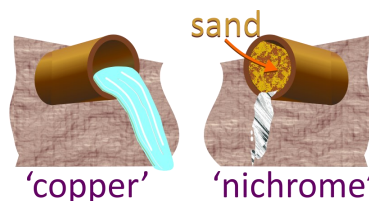

ond = nichrome.



# Resistivity - 2

The four Locktronics resistivity carriers are described in the table below:

Sam-ple	Material	Length L in m	Cross-section A in mm <sup>2</sup>
A.	Nichrome	0.5	0.075
B.	Nichrome	0.25	0.075
C.	Nichrome	0.5	0.21
D.	Constantan	0.5	0.075



(*Constantan - a copper-nickel alloy designed for use in resistors.*)

## Over to you

1. Use a multimeter to measure the resistance of each of the samples.
2. Record your results in the Student Handbook.
3. Answer the questions raised in the Student Handbook.

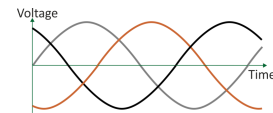

Comparing the results, following the approach below, shows the effect of the factors that affect resistance.

### The logic behind this approach:

#### A and B :

- the same material;
- the same cross-sectional area;
- **different length.**

Comparing them shows the effect of **length** on resistance.

#### A and C :

- same material;
- same length;
- **different cross-sectional area .**

Comparing them shows the effect of **cross-section** on resistance.

#### A and D :

- same length;
- same cross-sectional area;
- **different materials.**

Comparing them shows the effect of **resistivity** on resistance.

# Resistivity - 3

**Challenge**

Measure the resistivities of nichrome and constantan!

1. Build the layout shown below, using the nichrome carrier.
2. Make sure that the DC power supply is set to 6V!  
Ammeter - set up a multimeter to read currents up to 200mA DC.  
Voltmeter - set up a multimeter to read currents up to 6V DC.

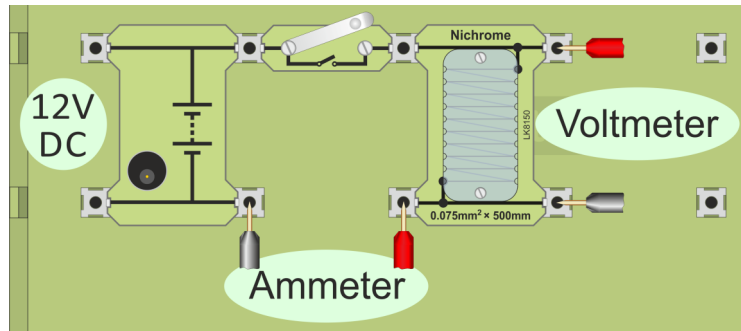

3. Connect the power supply and switch it on.
4. Close the switch.
5. Measure the voltage **V** across the nichrome and the current **I** flowing through it.
6. Calculate the resistance **R** of the nichrome using the formula:

$$R = \frac{V}{I}$$

7. Record your results in the table given in the Student Handbook.

## Resistivity of nichrome:

The results also allow us to calculate the resistivity of nichrome, using the formula:

$$\text{Resistivity } \rho = \frac{R \times A}{L} \quad \text{where } R \text{ is the resistance of the sample}$$

For example:

A sample of copper of length **L** = 1.5m, cross-section **A** = 0.01 mm<sup>2</sup> (= 0.01 x 10<sup>-6</sup> m<sup>2</sup>) has a resistance **R** = 2.5Ω.

Using these values, copper has a resistivity of:  $\rho = \frac{2.5 \times 0.01 \times 10^{-6}}{1.5} = 1.7 \times 10^{-8} \Omega\text{m}$

Following the same steps, use your results for the resistance of the nichrome sample to calculate the resistivity of nichrome. Write your result in the Student Handbook.

Now repeat the process, replacing the nichrome carrier with the constantan carrier.

Once again, record your results in the Student Handbook.



Electricity is **dangerous!**

Our bodies can sense electric currents as small as 1mA. A current of 10 mA DC can cause muscle contractions which mean that the victim cannot release the electrified object.

The voltage required to deliver these currents depends on a number of factors including the electrical resistance of the human body.

This, in turn, depends on factors like:

- the presence of sweat on the skin;
- the hydration level of the body - 45 to 70% of the weight of the body is water;
- the body fat content;
- where on the body the electrical contact occurs:
  - skin has a high resistance unless it has cuts or blisters;
  - current flowing from hand to foot experiences more resistance than current flowing from one finger to the next.

The resistance of the human body is typically between 1k $\Omega$  and 100k $\Omega$ .

Safety devices explored in the next sections:



**Fuses** and **circuit breakers** (MCBs) protect the appliance and the wiring connecting it, but **NOT** the user!

A fuse may happily pass a 10A current without 'blowing'. A human body would not be happy with a current of 10A!



The **RCD** (residual current device) compares the current it supplies **to** the appliance with the current, which flows back **from** the appliance. An imbalance might indicate a fault, such as an electric current flowing to earth through the user. The RCD 'trips', shutting off the electricity supply to the appliance and the user.

# The fuse



Electricity is ***dangerous!***

'Short-circuits' are a potentially harmful effect of electrical heating. Worn or damaged insulation lets wires touch, allowing very large currents to flow.

These can generate a lot of heat, causing fires.



One solution is an application of electrical heating, the fuse, a short length of wire made from a metal with a low melting point. It acts as the weakest point in the circuit. A large current flowing through it heats it so much that it melts.

This breaks the circuit, stopping the current before it causes damage.

The image shows the connections in a UK 13A plug.

The 'cartridge fuse' protects the wiring installation and appliance. It is important that the correct fuse rating is used for the appliance. These cartridge fuses typically come in values of 3A, 5A and 13A.



## Calculating fuse values:

We need:

- the power rating, **P**, of the appliance;
- the voltage, **V**, it is designed to work on.

From these, we first use the formula  $P = I \times V$  (or  $I = P / V$ ) to work out the normal current, **I**, flowing through the appliance. This current is fine - no overheating will occur. Then we choose a fuse value just greater than this so that the fuse will 'blow' cutting off all current when a problem occurs.

For example:

A modern TV - power rating (**P**) 200W on a 240V power supply (**V**).

Normal current (**I**) =  $200 / 240 = 0.8A$ .

**The best cartridge fuse rating for this is 3A.**

## Challenge

Calculate the normal current and best cartridge fuse value for the appliances listed in the Student Handbook.

# The circuit breaker

The modern consumer unit contains both MCBs (miniature circuit breakers) and RCDs.

However, these have different functions.



The circuit breaker switches off the current when it senses a fault. Like the fuse, it protects the appliance and the wiring connected to it. However, a fuse must be re-wired or replaced before normal operation can resume, whereas the mcb can be reset, by pressing a reset button or operating a switch.

1. Build the layout shown below.

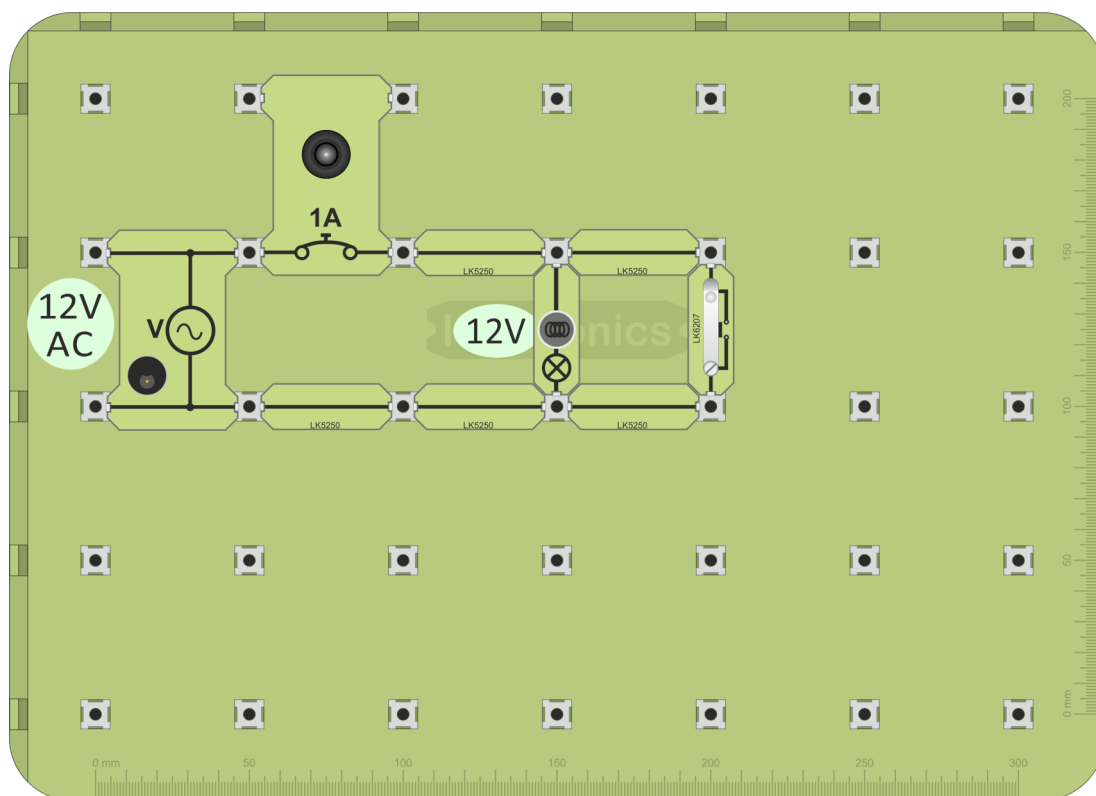

2. Connect the AC 12V power supply and switch on.
3. Press the circuit breaker 'Reset' button if necessary. The lamp should turn on.
4. Press the switch. The circuit breaker should trip as its rated current is exceeded.
5. Restore the supply by pressing the 'Reset' button again.



Add an ammeter to measure the current that causes the circuit breaker to 'trip'. Record your results in the Student Handbook.

# The RCD

A faulty electrical appliance might give the user an electric shock, with a current,

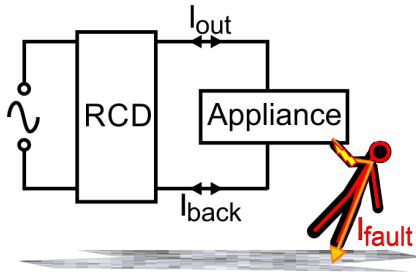

$I_{\text{fault}}$ , flowing to earth through the user. The **RCD** compares the current ( $I_{\text{out}}$ ) flowing **to** with that ( $I_{\text{back}}$ ) returning **from** an appliance. If the difference ( $I_{\text{out}} - I_{\text{back}}$ ) reaches a set value (typically 30mA), the RCD 'trips', shutting off the electricity supply.

## Over to you

## AC

1. Build the layout shown below.
2. Connect the AC 12V power supply and switch on.

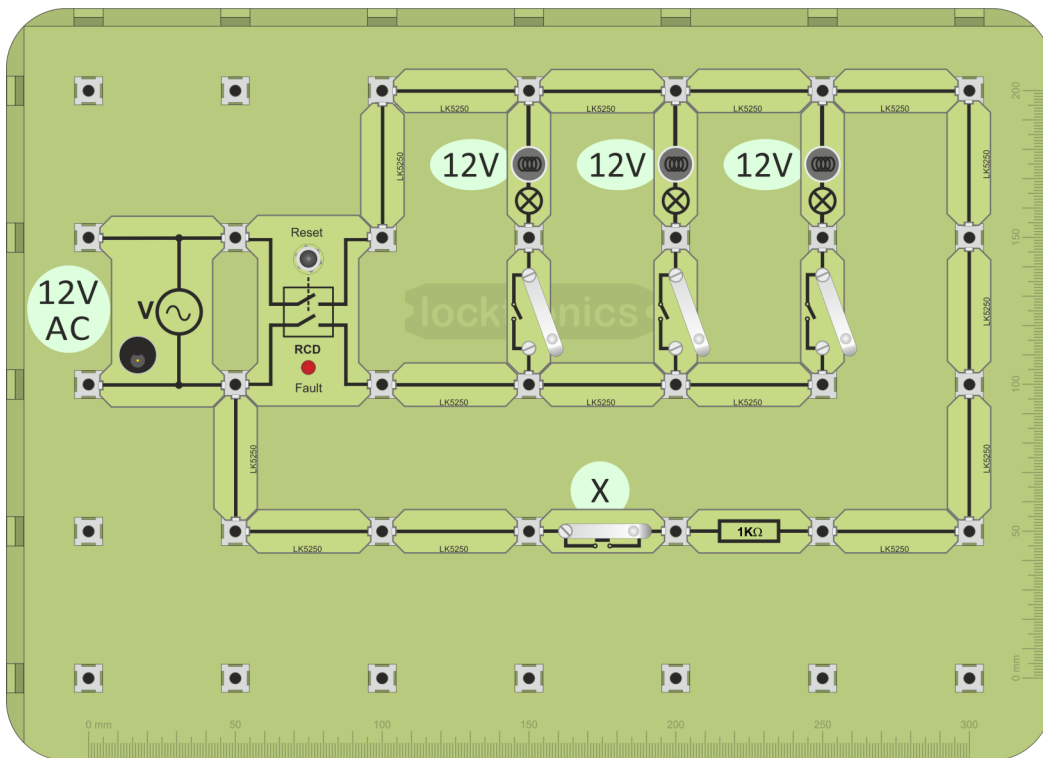

3. Press the 'Reset' button on the RCD if necessary.  
The three lamps can now be controlled separately by the on/off switches.
4. Simulate a fault by pressing switch 'X'. This diverts some current around the RCD, producing an imbalance in the currents leaving and returning to it.
5. The RCD 'trips', switching off the supply and lighting the 'Fault' LED on the RCD.
6. Restore the supply by pressing the 'Reset' button again.

## Challenge

Replace the 1kΩ resistor with a 250Ω variable resistor. Measure the fault current which causes the RCD to trip. Record your result in the Student handbook.



Electricity is ***dangerous!***

Sometimes, part of an electrical appliance, such as the outer metal casing, can become 'live' (wrongly connected to the mains electricity line cable.) Anyone touching this receives an electric shock which can cause serious injury or death.

'Earthing' is the procedure used to ensure that when part of an appliance becomes 'live', a large current flows causing a fuse to blow, or circuit-breaker or RCD to trip. In this way, the user is protected from electric shock. A cable, the 'earth' lead, connects vulnerable parts of the appliance to the earth, or ground.

The following diagram shows a common way to do this, using the TN-C-S system.

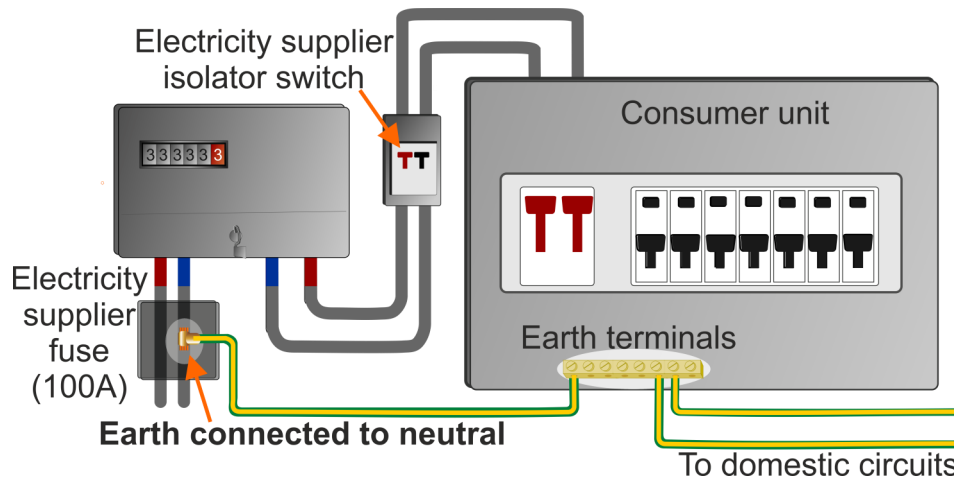

All earth leads are connected to the incoming neutral lead, usually inside the electricity supplier's fuse, where the electricity supply cables enter the building.

## Challenge

The next layout combines the benefits of a circuit breaker and a RCD.

Investigate it by:

- short circuiting a bulb;
- unbalance the currents in the 'line' and 'neutral' wires.

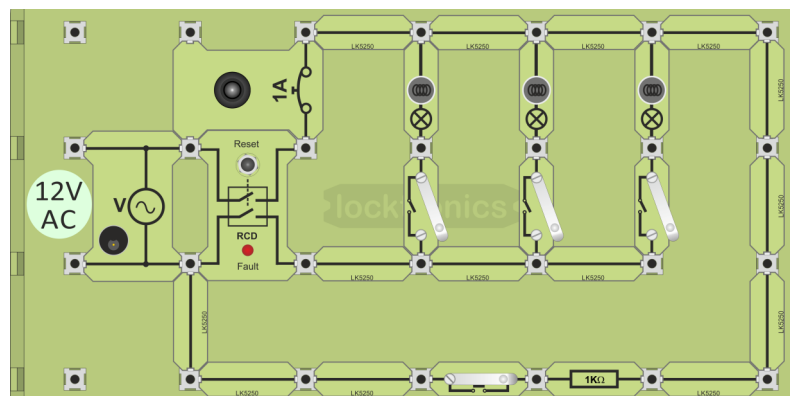

Make sure that you are clear about the different roles of the circuit breaker and RCD.



# The energymeter



## Energy:

- many forms - heat, light, sound, electricity etc.;
- measured in joules (J) or kilowatt-hours (kW-h);
- what we pay for, at filling stations, in electricity and gas bills etc.

## Power:

- energy used (or converted) per second;
- measured in watts (W), or kilowatts (kW). (1 kilowatt = 1 000 watts.)

## The energymeter: (Optional experiment)



- measures voltage, current, power and energy consumption;
- measurement chosen by pressing function button;
- 'Start / Pause' and 'Reset' buttons offer measurement of energy consumption over a period of time;
- display adjusts to show appropriate units.

## Using the energymeter to measure energy consumption:

1. Connect the energy source (battery, power supply, DC generator etc.) to the 'Source' terminals.
2. Connect the load (bulb, resistor, motor etc.) to the 'Load' terminals.
3. Plug in the energymeter power supply, and switch on. The display shows the word 'Initialising...' for a few seconds and then looks like the picture opposite.
4. Press the 'Start / Pause' button. The energymeter starts to record the energy transferred from the source to the load. The arrow '▶' at the lower right-hand corner of the display, shows that the meter is continuing to measure.
5. Press the 'Start / Pause' button again. The display freezes and the arrow turns to a 'P' to show that the meter has paused.
6. To clear the readings, press the 'Reset' button.

```
Energy 0J
Time 0s
```

# Measuring power

Over to you **DC/AC**

(Optional experiment)

1. Build the layout shown below.
2. Connect the 12V power supply and switch on.  
Plug in the energymeter power supply, and switch on.

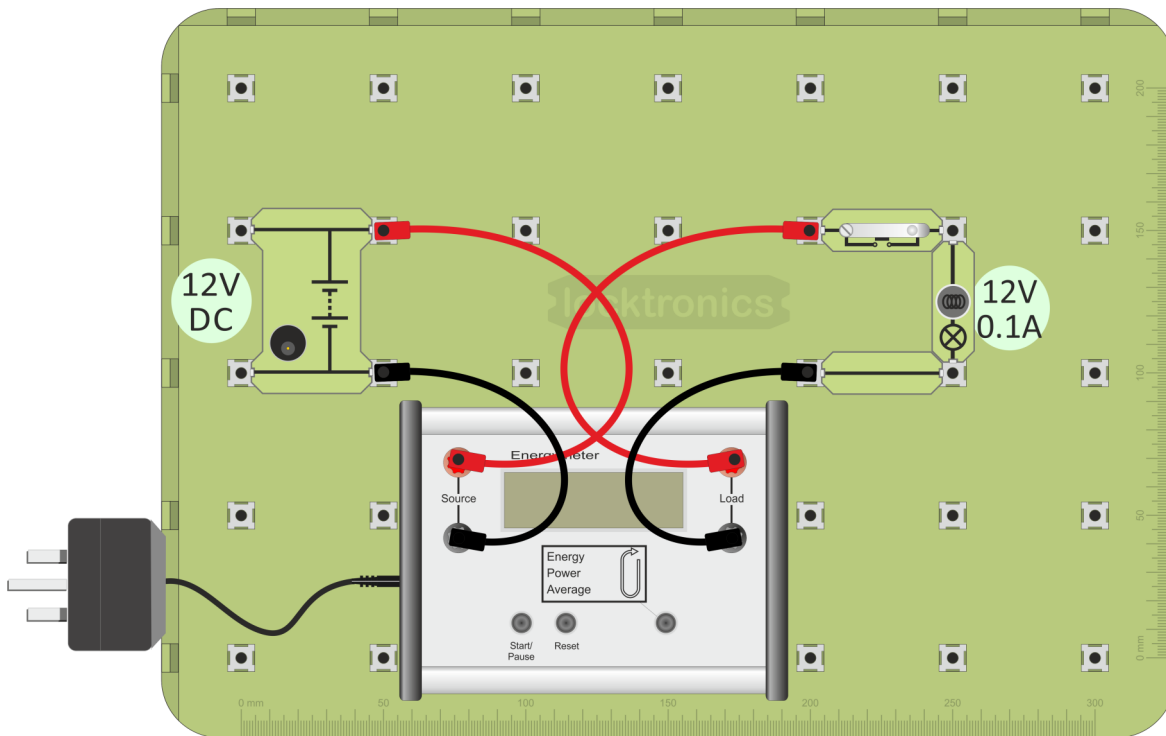

3. Press the 'Function' button until the display shows
4. Press down the push switch to make the bulb light.
5. The display now shows the power consumed by the bulb.
6. Record the reading in the Student Handbook.

## Challenge

Modify the circuit to measure the combined power consumption of **two** bulbs, connected:

- in parallel;
- in series.

In each case record your results in the Student Handbook.  
Comment on your results.



## Energy:

- comes from sources such as fossil fuels, the Sun, nuclear fission;
- appears in many forms, heat, light, sound, electricity etc.;
- is measured in units called joules (J) or kilowatt-hours (kW-h).

## Power:

- measures how much energy we use (or convert) each second;
- is measured in watts (W), or kilowatts (kW). (1 kilowatt = 1 000 watts.)

For example:

- a 100W lamp is much brighter than a 40W lamp - it converts more electrical energy into light each second;
- a 3kW heater generates three times as much heat as a 1kW heater.



## Calculating electrical power:

Use the formula:

$$P = I \times V$$

meaning :

**power = current x voltage.**

Example 1: What is the power rating of a bulb that takes a current of 0.25A from the mains 240V supply?

$$\text{Power} = \text{current} \times \text{voltage} = 0.25 \times 240 = 60\text{W}.$$

Example 2: The energy meter displayed the readings shown in the picture.

V 9.43V | Power  
I 3.59A | 33.9W

$$\text{The power measurement} = \text{current} \times \text{voltage} = 3.59 \times 9.43 = 33.9\text{W}$$



In the UK, consumers are encouraged to use 'smart' meters, offering a range of functions including displaying the power dissipated in individual appliances or in the whole domestic installation.



# Electromagnetism - 1

**abc** 'Ordnance Survey' maps use 'contour lines' to show the steepness of slopes.

On weather maps 'isobars' show weather patterns. Winds are strongest where the isobars are closest together.

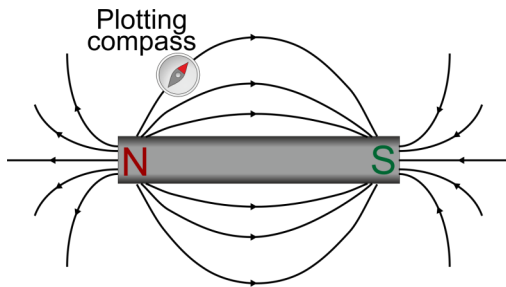
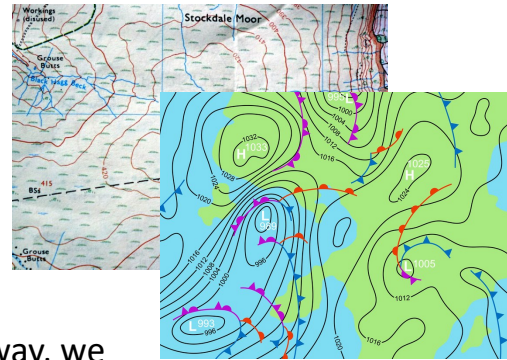

In the same way, we map magnetic fields using 'lines of force' or 'flux lines'.

The magnetic force is strongest where they are packed most tightly.

A line of force is the path that a free north pole (which doesn't exist either!) would follow.

A free south pole, if it existed, would go in the other direction.

In practice, the needle of a plotting compass indicates a line of force, as shown.

You don't trip over contour lines when walking up a hill! 'Contour lines', 'isobars' and

**Over to you** **DC** 'lines of force' don't exist! They are just tools used to create different kinds of map.

1. Build the layout shown. It is similar to that used in the activity on page 18.
2. Connect the 12V DC power supply and switch on.

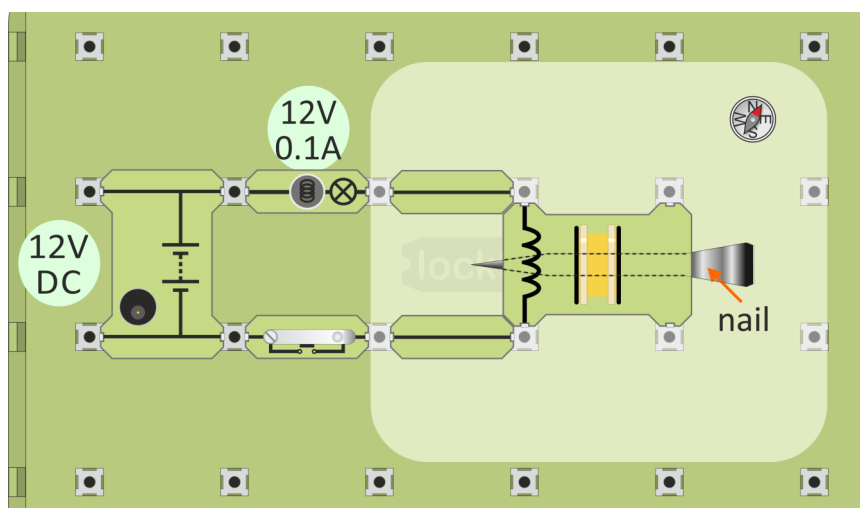

3. Move the plotting compass around the area shown in the lighter shade. As you do so, visualise the 'lines of force' around the electromagnet.
4. Sketch a magnetic field pattern for the electromagnet on the template given in the Student Handbook.

## Over to you

1. Build the layout shown.
2. To begin with, the cylindrical magnet sits inside the coil, as shown.
3. Now, withdraw the magnet from the coil as quickly as possible, watching the voltmeter as you do so.
4. The effect you are looking for is very short-lived. A digital voltmeter samples its input at intervals and so may have missed it - the reading stayed at zero. In that case, repeat the steps several times until you catch the resulting effect on the meter.

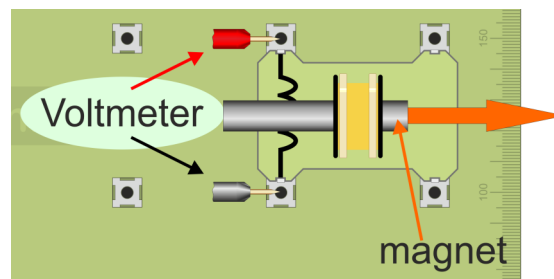

5. Next, turn the magnet the other way round and repeat the process.
6. Investigate the effect of speed of movement on the size of the voltage produced.

It can be shown that the voltage generated has :

- a **size** that depends on the speed of movement and the number of turns of wire in the coil;
- a **direction** that depends on the direction of motion.

### Fleming's Right-hand Rule (also known as the *dynamo rule*):

Fleming devised a second, equally painful gesture, in order to predict the direction of the generated current, this time using the **right-hand**.

Set the **F**ore finger in the direction of the magnetic **F**ield (from North pole to South pole,) and the thu**M**b in the direction of the **M**otion.

The **C**entre finger now points in the direction of the resulting **C**urrent.

This is illustrated in the diagram.

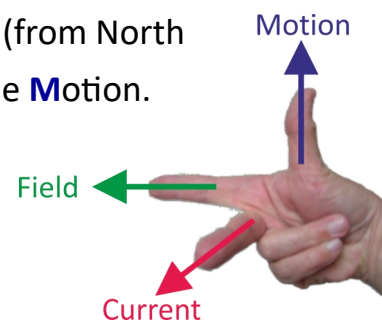

# Generating electricity - 1



The requirements for generating electricity using electromagnetism are:

- a magnetic field;
- a conductor;
- relative motion between them.

Most generators rotate, often driven by turbines like the one shown, operated by high-pressure steam from coal-fired, gas-fired or nuclear power stations.

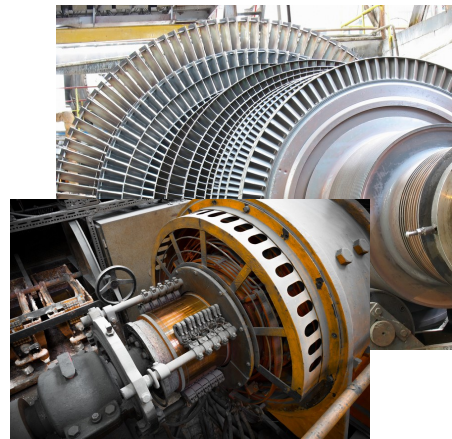

The principle is illustrated by looking at a single coil of wire rotating in a magnetic field. The diagram shows this coil, cutaway and disappearing into the sheet of paper. There is a magnetic field from left to right.

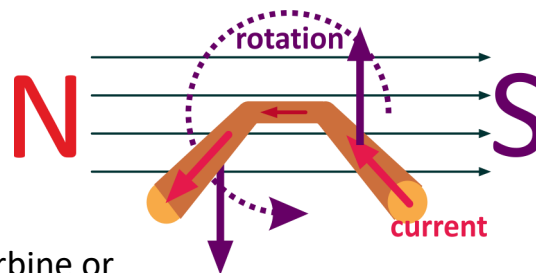

The coil is driven by a turbine or similar device. As one side of the coil moves up, the other side moves down, both in the same magnetic field. The currents induced in the two sides flow in opposite directions, one into the paper, the other out of it. In other words, the induced current flows around the coil.

## Challenge

Apply Fleming's Right-hand rule to check the direction of current flow in the two arms of the coil.

Reverse the direction of rotation and you reverse the direction of the current flow.

Electrical connection to the rotating coil can be made in two ways using:

- a commutator - produces a DC output;
- slip-rings - gives an AC output.

## Challenge

Find out the difference between commutators and slip-rings. Write an explanation in the Student Handbook.



# Generating electricity - 2



Most electricity is generated by a rotating magnetic field inside a stator containing coils of wire.

The magnetic field could be produced by rotating a magnet. However, more often it is produced by a rotating electromagnet, using a small DC current from an 'exciter'.

In modern systems, this current is drawn from the main generator output, rectified to DC and fed to the electromagnet via 'slip rings'.

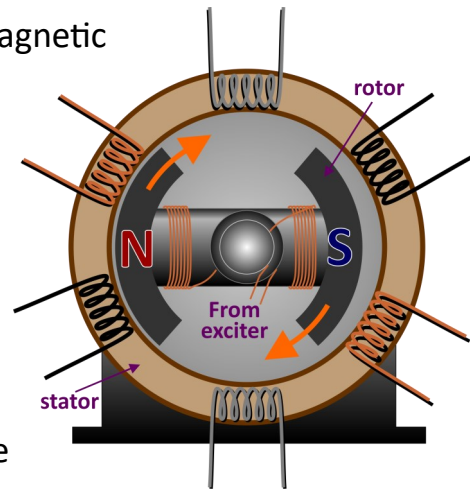

The diagram shows the basics of a three-phase alternator, which generates three AC outputs, out of step with each other. The graph shows this output.

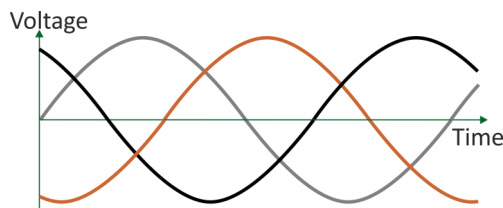

## Over to you

Time to generate some electricity!

The hardware - a hand-cranked generator:

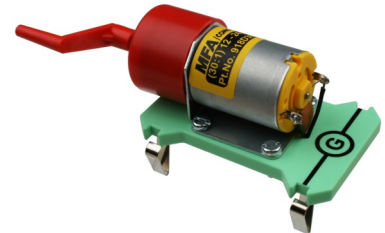

1. Build the layout shown opposite.

Make sure that you use a 12V LED bulb carrier!

(Look for the '+' sign at one end!)

2. **GENTLY**, turn the handle on the generator.

The LED bulb should light.

If it does not, turn it in the opposite direction.

(The generator outputs DC. Some LED bulbs are polarised—they need connecting the right way round..)

3. Replace the LED carrier with a MES lamp holder containing a 12V 0.1A filament lamp.

Turn the handle again.

Which is easier to turn?

(This relates to the efficiency of the filament lamp and LED, discussed earlier.)

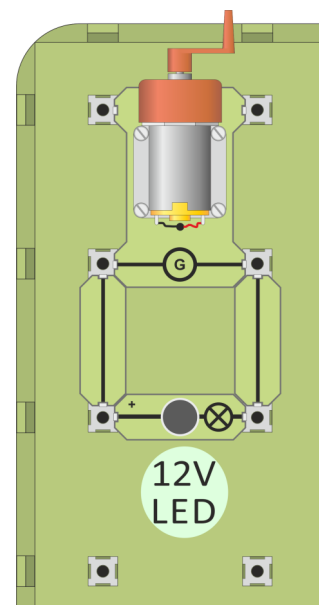



**abc** Generating electricity as AC allows us to use of transformers to change the 'format' of the electricity supply. They can change from high to low voltage, or the reverse, without losing much energy as heat in the process.

Moving a magnet into a coil of wire generates electricity.

This activity starts by

replacing the magnet with an electromagnet, using a transformer carrier. This holds two separate coils of wire,

with no electrical connection between them. A rod made from ferrite a magnetic



**Over to you** **DC**

material can be slid into the coils.

1. Build the first layout shown below.

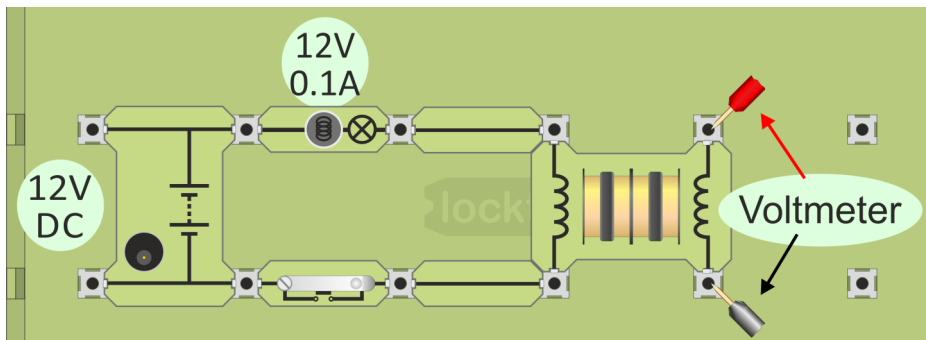

The ferrite rod is not used yet. The left-hand coil is the electromagnet.

A voltmeter, connected to the other coil detects any electricity generated in it.

If using a multimeter for this, set it on its most sensitive DC range.

The 12V lamp shows when a current is present and limits it to protect the coil.

2. At the moment, the voltmeter reads zero. Press and hold down the switch, watching the meter as you do so. You should see a brief pulse of electricity.
3. Now place the ferrite rod in the centre of the coils.

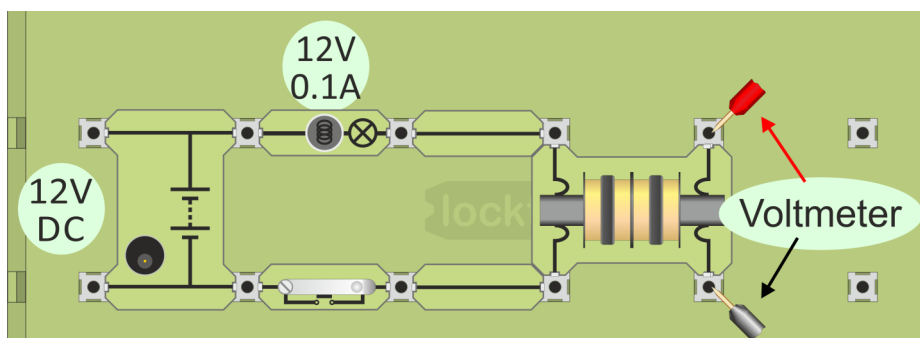

# Transformers - 2

The requirements for generating electricity using electromagnetism are:

- a magnetic field;
- a conductor;
- relative motion between them.

In the last activity, we succeeded in generating electricity but only in short pulses.

We had a magnetic field and a conductor, but where was the relative motion?

This was provided by the switch. When it was off, there was no magnetic field.

When turned on, a magnetic field built in the coil. It moved through the turns of wire as it built up.

Now we aim to generate a continuous electricity supply, by connecting the electromagnet to AC.

## Over to you **AC**

1. Build the layout shown below. It is the same as in the previous activity except that it uses an AC power supply. The voltmeter must now be capable of measuring AC. If you are using a multimeter, set it on the most sensitive AC voltage range.

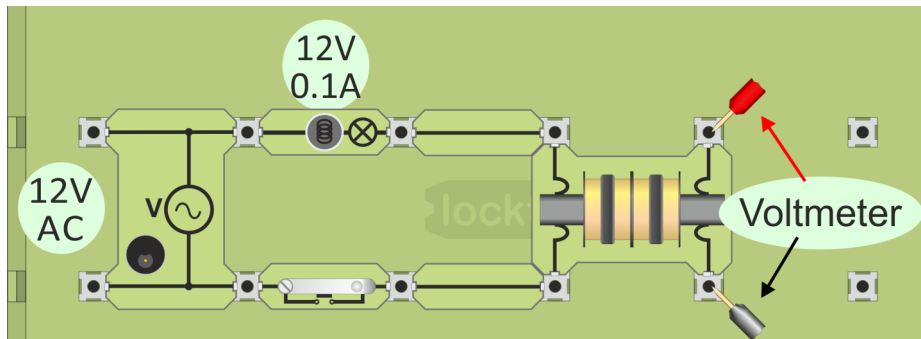

2. As before, press and hold down the switch, watching the meter as you do so. This time, there should be a steady reading on the voltmeter for as long as the switch is closed.



Although we cannot see it, the magnetic field is building up and collapsing in step with the AC current, providing the motion that we need to generate electricity.

The role of the ferrite rod is to intensify the magnetic field in the second coil.

Notice that the efficiency of this transformer is very low. The left hand coil, called the primary, is supplied with 12V AC. However, the output from the other coil, called the secondary, is much smaller.

3. Answer the questions in the Student Handbook.

# Step-down transformer

**abc** Let's refine the transformer a little!

The strength of the magnetic field in the primary depends on factors like:

- the number of turns in the primary coil,
- the current flowing through it and so the voltage applied to it.

The voltage generated in the secondary coil depends on factors like:

- the strength of the magnetic field generated by the primary;
- the number of turns of wire in the secondary coil;
- how effectively the magnetic field of the primary links with it.

In a step-down transformer, the primary coil, the one supplied with AC power, has more turns of wire than the secondary, the one that generates the output voltage.

In this activity, we use a commercial, but not very efficient, transformer with a turns ratio of 2:1, meaning that one coil

has twice as many turns as the other. The primary



**Over to you**

**AC**

will be the '2' coil, and the secondary the '1' coil.

1. Build the layout shown below.

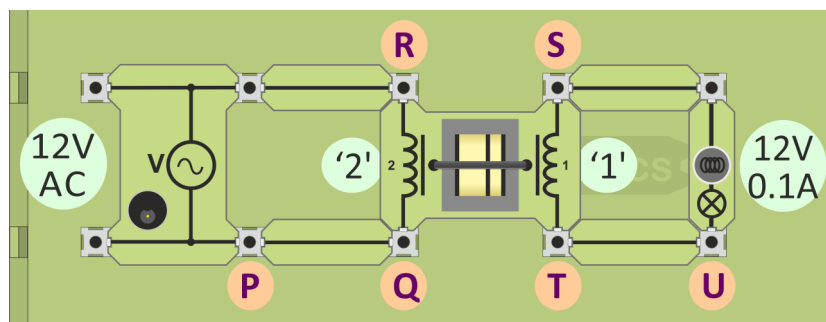

2. Connect a multimeter, set to measure AC voltage, to points **Q** and **R** to measure the voltage,  $V_p$ , across the primary (the '2') coil.
3. Connect it across points **S** and **T** to measure the voltage,  $V_s$ , across the secondary.
4. Change the multimeter range and connections to read AC currents.
5. Remove the connecting link between points **P** and **Q** and replace it with the multimeter probes to measure the primary current  $I_p$ . Then replace the link.
6. Remove the connecting link between points **T** and **U** and use the multimeter to measure the secondary current  $I_s$ .
7. Record all readings in the table in the Student Handbook.

# Step-up transformer

**abc** In a step-up transformer, the primary coil has fewer turns than the secondary.

The National Grid uses both step-up and step-down transformers. At a power station, the output voltage is stepped up (typically to 11kV or higher). By doing so, a smaller current needed to transmit a given amount of electrical power and so less energy is wasted in the transmission cables. At the substation, a step-down transformer then lowers the voltage, typically to 440V and 240 V.

In the home, step-down transformers are common, used as battery eliminators for

electronic devices such as computers, televisions, mobile phones (and Matrix Locktronics circuits!) The step-down transformer outputs an AC voltage which then needs

rectification to DC and smoothing before being used as a power supply.

In this activity we will use the same transformer connected the other way round, so that the primary will be the '2' coil, and the secondary the '1' coil.



## Over to you **AC**

1. Build the layout shown below. It is similar to that used in the previous activity except that the 12V lamp is used in the primary circuit to reduce the voltage applied to the primary coil. A 10kΩ resistor is used as the load.

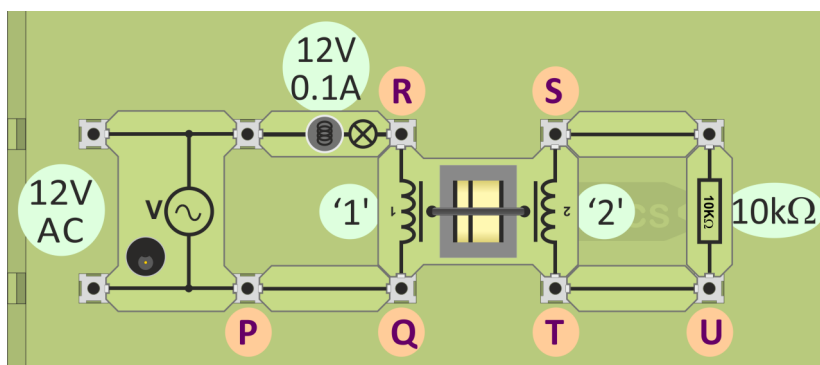

2. Connect a multimeter to points **Q** and **R** to measure the primary voltage,  $V_p$ .
3. Connect it across points **S** and **T** to measure the secondary voltage,  $V_s$ .
4. Change to an AC current range. Remove the connecting link between **P** and **Q** and use the multimeter to measure the primary current  $I_p$ . Then replace the link.
6. Remove the link between **T** and **U** and measure the secondary current  $I_s$ .
7. Record all readings in the table in the Student Handbook.

# Transformer relationships



The first version of the transformer carrier showed the transformer principles, but was very inefficient.

The second version, the commercial transformer, was a big improvement - two coils sitting side by side, as in the prototype, but now linked by a more elaborate core, which threads through the centre of the coils, and wraps around the outside too. The result is a much more effective magnetic field linkage between the coils.



What the results show:

- The ratio  $V_p : V_s$  for both types of transformer is related to the turns ratio.
- The transformer relation says that for an ideal transformer:

$$V_p / V_s = N_p / N_s$$

where  $N_p$  is the number of turns on the primary coil;  
and  $N_s$  is the number of turns on the secondary coil.

In general terms:

- a step-up transformer 'steps up' the voltage (here, virtually doubles it,) but 'steps down' the current - the primary current is much greater than the secondary.
- a step-down transformer 'steps down' the voltage, but it delivers the same secondary current as before for a much smaller primary current.
- For an ideal transformer (100% efficient):

$$P_{IN} = P_S$$

where  $P_{IN}$  is the power delivered to the primary,  
and  $P_{OUT}$  is the power delivered by the secondary;

and  $I_s / I_p = N_p / N_s$

## Verdict:

There is nothing magical about the transformer. It changes the 'format' of the electricity supply, but at a cost in terms of energy wasted.

# Electrical Installation Level 2

## Student Handbook

-

# For your records

## Page 4 - Circuit training:



Complete the table, which compares Locktronics components with those used in domestic electricity installations.

Locktronics	Domestic electricity
	like a domestic bulb, but designed for lower voltage and current.
Connecting links	
	the consumer unit - where the domestic circuits connect to the National Grid.

## Page 8 - AC vs DC - 2:

The 12V AC power supply has a rms voltage of .....

## Page 9 - Measuring AC:

Here is the voltage / time graph for an AC signal.

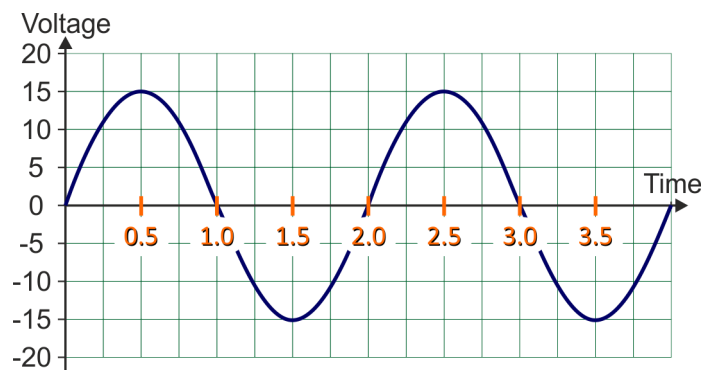

Complete the following statements about it:

Peak voltage = ..... V

Peak-to-peak voltage = ..... V

Periodic time = ..... s

Frequency = ..... Hz



Page 10 - AC and DC again:

The graph compares the voltage / time behaviour of the AC and DC power supplies.

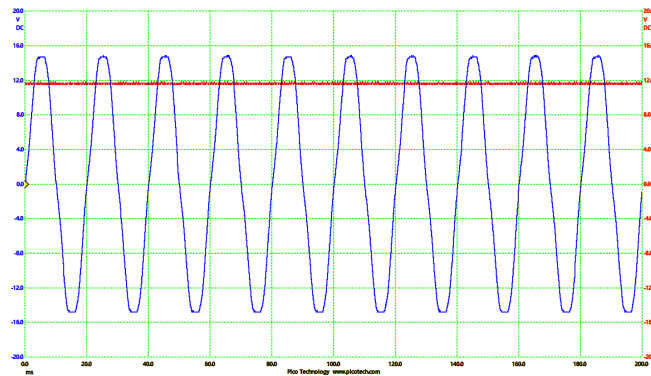

Label the r.m.s. value of the AC signal.

In the UK, the AC mains electricity supply has a r.m.s. voltage of 140V.

What is the peak voltage of this supply? .....

Complete the table to show peak and corresponding r.m.s.voltages.

Which example, **A**, **B**, **C** or **D**, has a peak-to-peak voltage of 40V? .....

	Peak voltage	R.m.s. voltage
A	10V	
B		14V
C	18V	
D		28V

Page 11 - Conductors and Insulators:





Materials that conduct	Materials that do not conduct

What do you notice about the substances that are metals in this list?

.....  
 .....

Page 12 - Circuit diagrams:

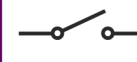
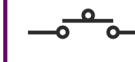
Common circuit symbols:

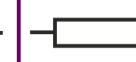
					
AC power supply	Battery or DC power supply	Toggle switch	Push switch	Lamp	Resistor

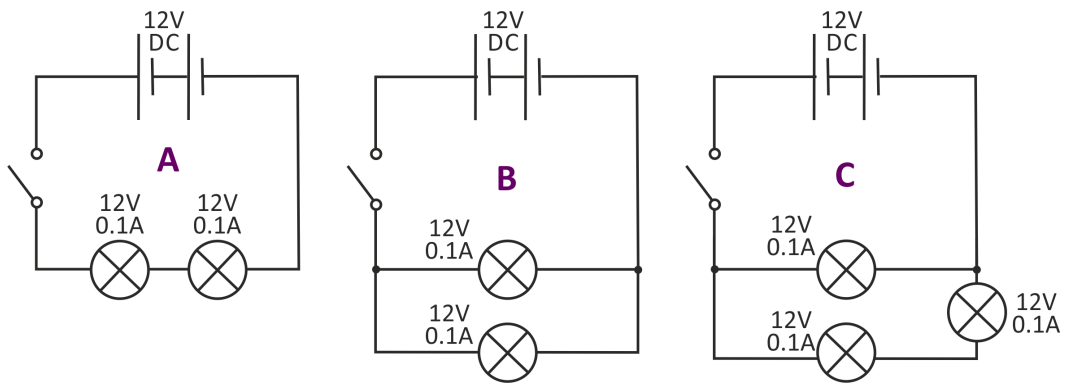

Circuit ..... draws the biggest current from the power supply.

Page 13 - Current path - 1:

**Power supply:**

- drives current around the circuit;
- has two terminals (connection points) one 'positive' the other 'negative';
- current flows from positive to negative.

**Connecting links:** allow current to flow freely.

**Circuit:** continuous length of conductor joining the power supply terminals.

What is the effect of:

- changing the shape of the circuit;

.....  
 .....

- changing from an AC to a DC power supply?

.....  
 .....

## Page 14 - Current path - 2:

The diagram shows how to wire up a pendant light to a ceiling rose and control it with a switch.

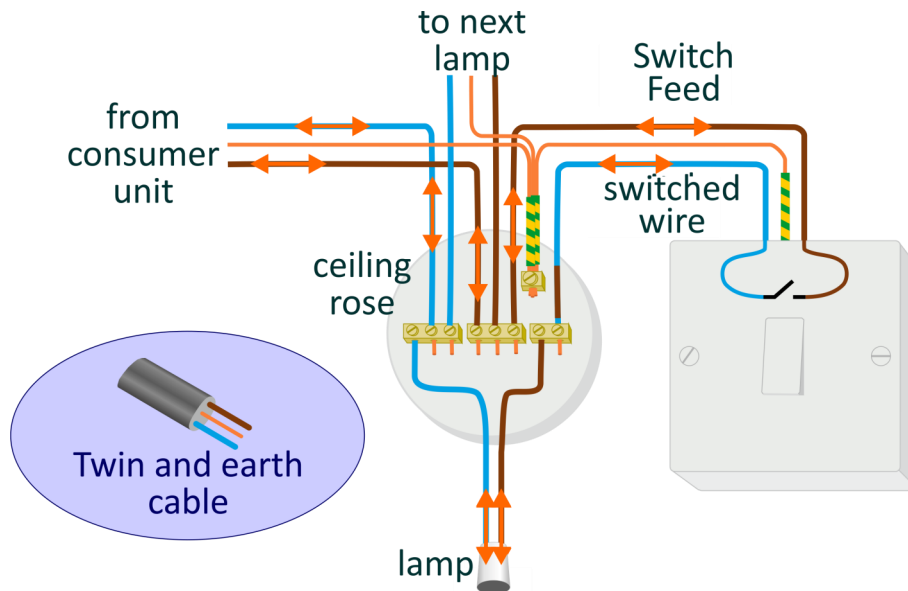

## Page 16 - Heating effects:

**When an electric current flows , its energy is converted to heat.**

In a filament lamp, the filament, usually made from tungsten, is heated to such a high temperature that it glows yellow-hot, giving out light. However, typically only ~5% of the electrical energy appears as light.

Lighting using LEDs (Light-Emitting Diodes) can be 10 times more efficient.

The reverse process takes place in a thermocouple. When its junction of different metals is heated, it generates a DC voltage. It is be used to measure temperature.

## Page 18 - Magnetic effects:

**An electric current is ALWAYS accompanied by a magnetic field.**

The principal application of the magnetic effect of electricity is the electric motor, widely used in domestic appliances. Other applications of electromagnetism include:

- transformers - in power supplies, such as mobile phone chargers;
- generators - used to power tools or as a stand-by in case of power cuts;
- loudspeakers - in radios, televisions, computers and mobile phones;
- circuit breakers - protection against current overload and overheating.

## Page 20 - Motor effect - 2:

### **Fleming's Left-hand Rule:**

John Ambrose Fleming devised a way to work out the direction a wire will move in (also known as the *motor rule*):

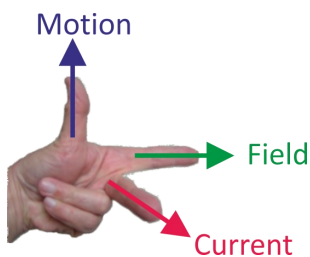

- Clamp your **left**-hand to the corner of an imaginary box, so that thumb, fore-finger and centre-finger are at right-angles to each other.
- Line up the **F**ore-finger so that it points along the magnetic **F**ield (from North pole to South pole,)
- Line up the **C**entre-finger with the direction of the **C**urrent (from positive battery terminal to negative.)
- The thu**M**b now points in the direction of the resulting **M**otion.

## Page 22 - Chemical effects:

### **An electric current can create/be created by a chemical reaction.**

An **electric current** is a flow of electrons, (tiny particles found in all atoms.)

A **chemical reaction** involves electrons transferring between atoms.

Batteries illustrate the link between them. In a 'dry' battery, a chemical reaction generates a voltage which can drive an electric current. In rechargeable batteries, this process can be reversed - a current flowing the 'wrong' way can reverse the chemical reaction, storing up energy for later use.

In electroplating, an electric current through a chemical solution deposits a metal on one of the electrodes in order to protect it from corrosion or to improve its appearance.

## Page 23 - Connect in series:

In a series connection:

- devices are connected one after the other in a line;
- there are no alternative routes - no branching;
- only one path exists for the current through the connection.

What do you notice about the brightness of the **three** lamps connected in series?

.....

What happens if you unscrew one of the bulbs?

.....

How does the brightness of the **two** lamps compare with the previous circuit?

.....

What does this show about the current flowing in this circuit?

.....

Does unscrewing a bulb have the same effect as in the previous circuit?

.....

## Page 24 - Connect in parallel:

In a parallel connection:

- devices have their own separate 'branch-line';
- the ends of a device connect to corresponding ends of all other devices;
- each device has its own path for the current through the connection.

What do you notice about the brightness of the three lamps?

.....

.....

How does their brightness compare to the three lamps connected in series?

.....

.....

What happens if you unscrew one of the bulbs?

.....

Page 25 - Series / parallel - 1:

What do you notice about the brightness of the three lamps?

.....

What happens when you unscrew bulb 'P'?

.....

What happens when you unscrew bulb 'Q'?

.....

Explain these differences:

.....

.....

.....

Page 26 - Series / parallel - 2:

What do you notice about the brightness of the three lamps?

.....

What happens when you unscrew bulb 'P'?

.....

What happens when you unscrew bulb 'Q'?

.....

Explain these differences:

.....

.....

.....

## Page 27 - MES bulbs:

MES bulbs are mass-produced to reduce cost. As a result, they are not *quite* identical. They may have different filament lengths or diameters or experience different heat losses.

Given identical conditions, they will not give the same brightness.

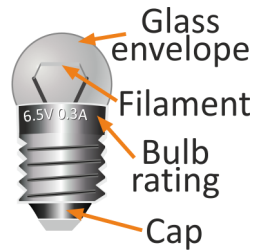

## Page 28- Serial / parallel applications:

In domestic lighting, it is important that lamps operate independently especially when one bulb 'blows'. Hence they are connected in **parallel**, as the diagram shows.

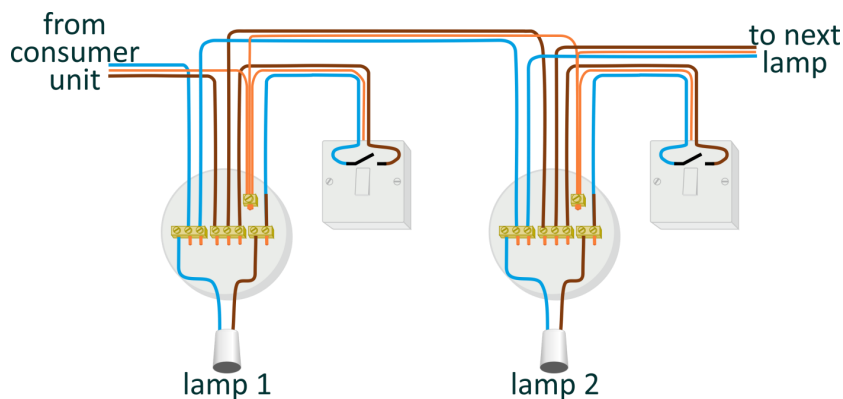

Controls, like fuses, switches and thermostats, must be able to 'break' the circuit and stop current flow to the load device, such as a heater. As a result, they are connected in **series** with the load.

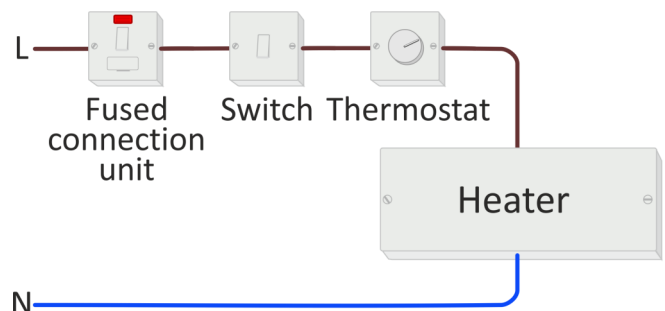

## Page 29 - Staircase circuit - 1:

With switch A and switch B in the positions shown, is the bulb lit?  
 .....

Switch A is moved to the other position, as the next diagram shows.

Draw the new current path on the diagram.

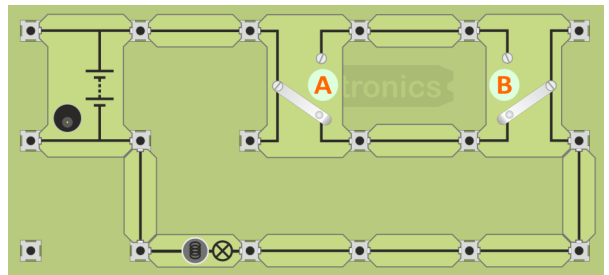
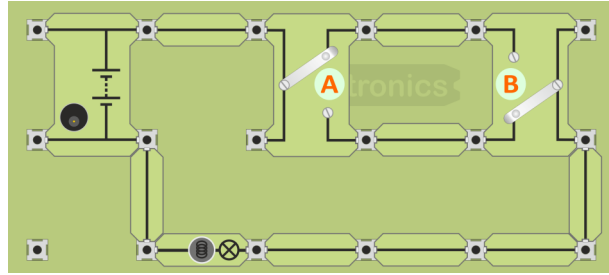

## Page 30 - Staircase circuit - 2:

A changeover switch, also called a SPDT (single-pole-single-throw) switch, has three terminals: **C** (for Common), **L1** and **L2**. Operating it connects **C** to either **L1** or **L2**.

The '2-wire control' system is shown in the next diagram.

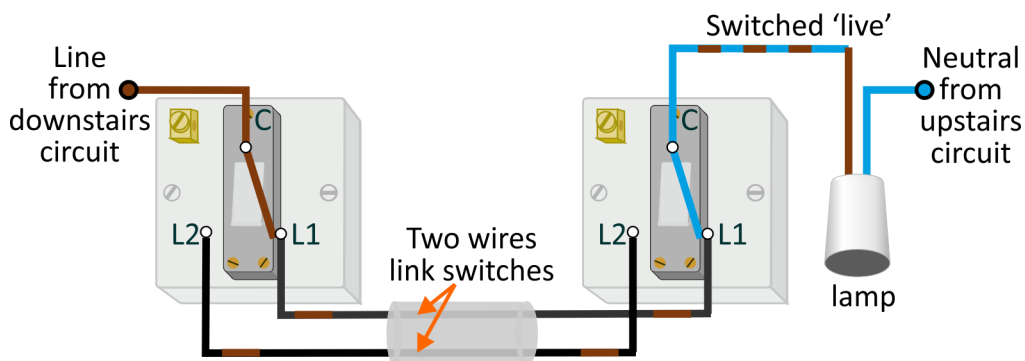
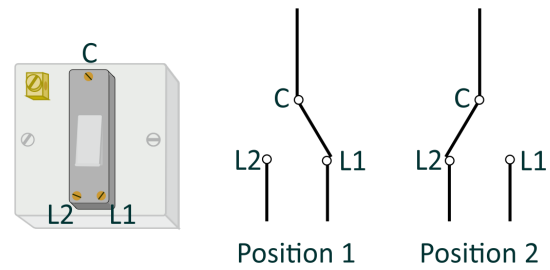

It works **but** there may be safety issues!

- The circuit may take its line connection from one circuit (e.g. downstairs) and its neutral from another (e.g. upstairs.) An electrician working on it might switch off the upstairs lighting circuit and think that the system is safe to work on. However, parts may still be 'live' because the downstairs circuit is still switched on.
- An RCD monitoring the downstairs circuit may trip unnecessarily because line and neutral currents downstairs may be different. Similarly, an RCD looking after the upstairs circuit may be unreliable.



## Page 31 - Staircase circuit - 3:

The left-hand diagram shows one set of switch positions which cause the lamp to light. On the diagram, draw the path that the current takes around this circuit.

On the right-hand diagram, complete the images of the switches to show another set of switch positions that would cause the lamp to light.

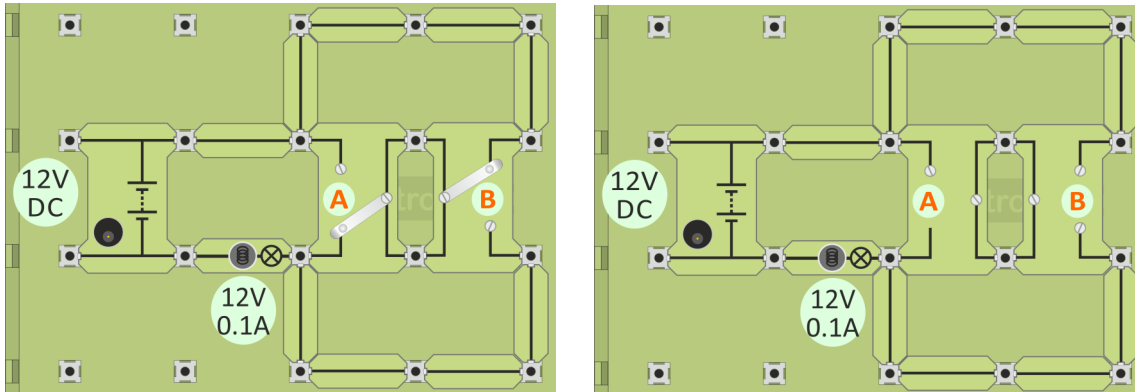

## Page 32 - Staircase circuit - 4:

The next diagram shows a practical form of the '3-wire control' system, so-called because three wires link the two switches together.

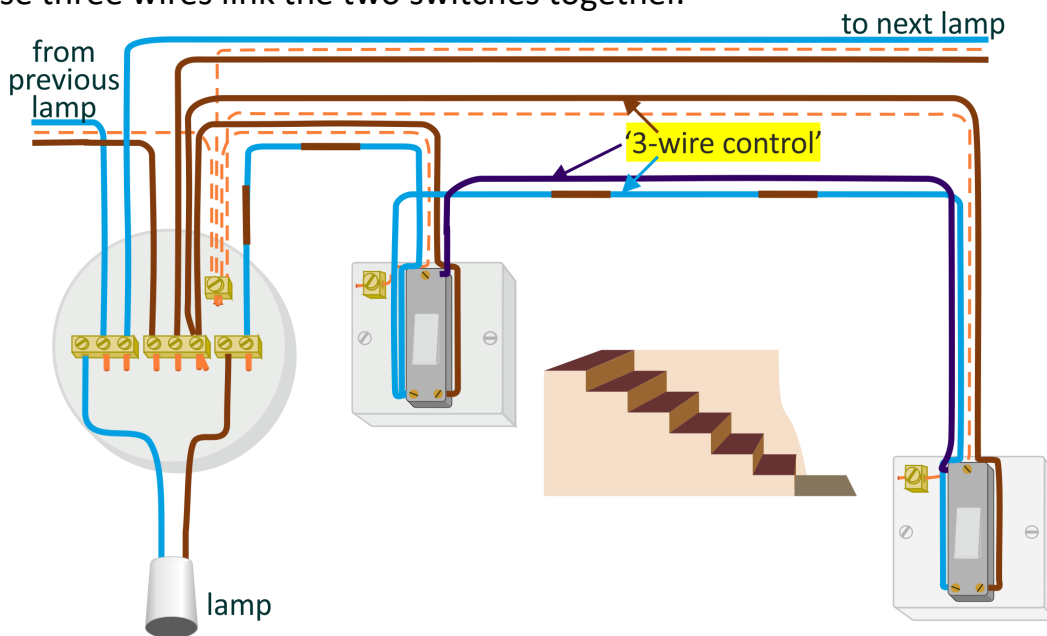

Points to note:

- **L1** terminals are connected together and to the incoming 'line' connection;
- **L2** terminals connected to each other and to the 'switched wire';
- **C** terminals are connected .

## Page 33- 3-way control - 1:

With a third switch - an intermediate switch, (also called 'reversing' or 'DPDT', (double-pole-double-throw,)) the lamp can be controlled by all three switches. With the switches are in the positions shown, and the intermediate switch making the connections shown on the carrier, draw the current path on the diagram.

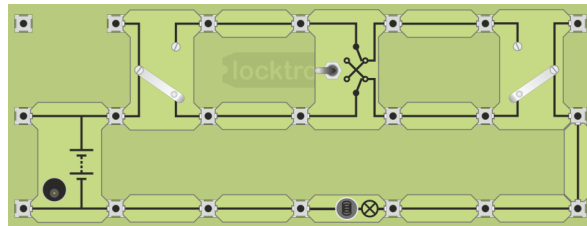

This is another '2-wire control system' and suffers from the same potential problems as the 2-way (staircase) system.

## Page 34 - 3-way control - 2:

An intermediate switch has four terminals, two labelled **L1** and two labelled **L2**.

Operating it makes the connections shown.

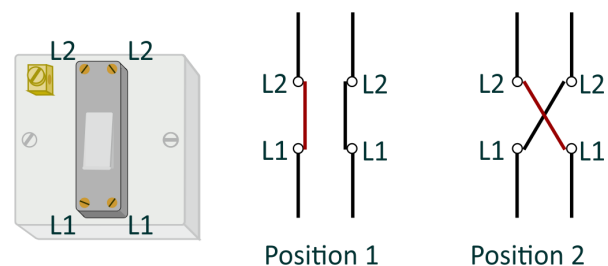

The three-way switching circuit is shown below:

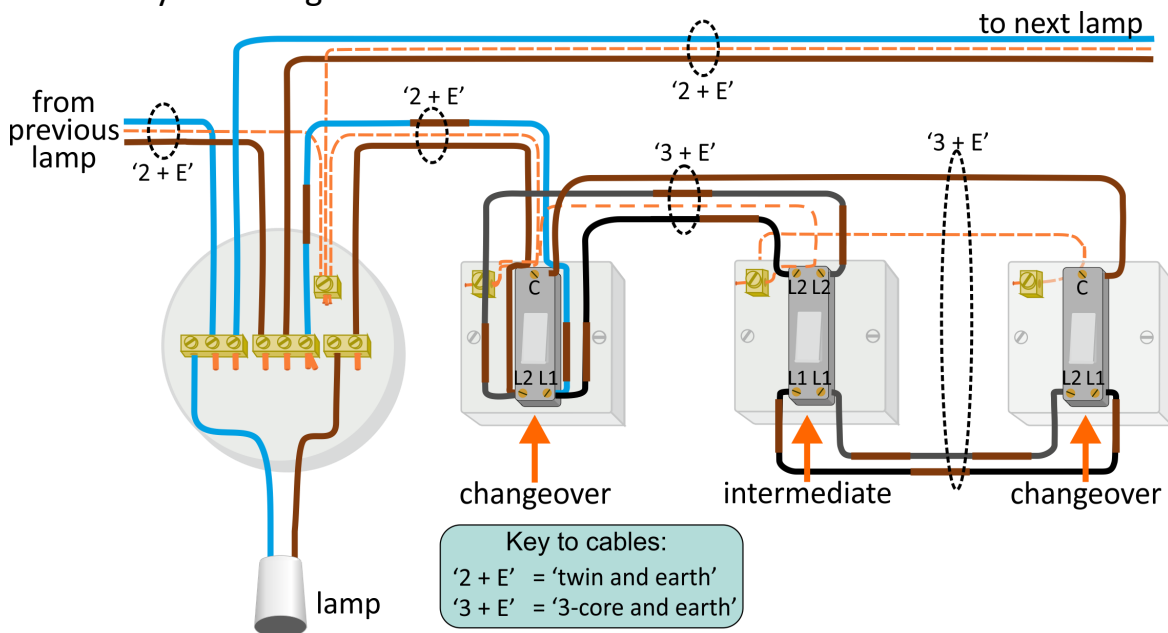

Trace through the connections and compare it with the '2-wire control' system at the top of the page.

## Page 35 - Measuring voltage - 1:

Voltage:

- is a measure of the force pushing the electrons around the circuit;
- measures energy lost or gained as an electron moves through part of a circuit;
- is measured with a voltmeter connected in parallel with the component.

 - circuit symbol for a voltmeter .  
voltmeter

When using a multimeter, **before you switch it on:**

- take care to plug the probes into the correct sockets;
- select the correct range.

Using a multimeter to measure voltage:

- Plug a wire into the black '**COM**' socket and the second one into the red '**V**' socket.
- Select the 20V DC range, (or a range higher than the reading you expect.)
- Plug the other ends of the wires into the sockets at the ends of the component under investigation.
- Switch on the multimeter when you are ready to take a reading.
- A '-' sign in front of the reading means that the meter wires are connected the wrong way round. Swap them over to get rid of it!
- Now select a lower range if that is appropriate.



## Page 36 - Measuring voltage - 2:

Voltage between points	Reading
1 and 2 (Lamp 1)	
2 and 3 (Lamp 2)	
3 and 4 (Lamp 3)	
5 and 6 (Power supply)	

What do you notice about the sum of the voltages across the three lamps?

.....

## Page 37 - Measuring voltage - 3:

Voltage between points	Reading
1 and 2 (Lamp 1)	
3 and 4 (Lamp 2)	
5 and 6 (Lamp 3)	
7 and 8 (Power supply)	

Comment on these results:

.....

## Page 38- Measuring voltage - 4:

Voltage between points	Reading
1 and 2 (Lamp 1)	
3 and 4 (Lamp 2)	
4 and 5 (Lamp 3)	
6 and 7 (Power supply)	

Comment on these results:

.....  
.....  
.....

## Page 39 - Measuring current - 1

Current:

- measures the number of electrons passing any point in the circuit each second;
- measures the rate of flow of electrical charge in the circuit;
- is measured with an ammeter connected in series with the component.

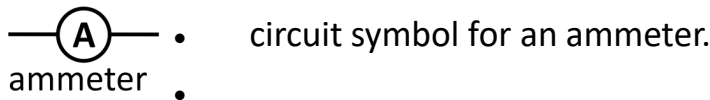

Using a multimeter to measure current:

- Plug a wire into the black '**COM**' socket and a second into the red '**mA**' socket.
- Select the 200mA DC range, (or a range higher than the reading you expect.)
- Break the circuit where you want to measure the current, by removing a link or component and plug the two multimeter wires in its place.
- Switch on the multimeter when you are ready to take a reading.
- Now select a lower range if that is appropriate.
- Beware - The ammeter range is protected by a fuse located inside the body of the multimeter. This may have 'blown', in which case the ammeter will not work.

## Page 40 - Measuring current - 2:

Current at point:	Reading
P	
Q	
R	
S	

Comment on these results:

.....

.....

.....

.....

## Page 41 - Measuring current - 3:

Current at point:	Reading
P	
Q	
R	
S	

Comment on these results:

.....

.....

Estimate of the current at point **T**: .....

How did you obtain this estimate?

.....

.....

## Page 42 - Measuring current - 4:

Current at point:	Reading
P	
Q	
R	
S	
T	

Why are the readings at points '**P**' and '**T**' equal?

.....

.....

Why are the readings at points '**Q**' and '**S**' equal?

.....

.....

What does this imply for the brightness of the two bulbs between these points?

.....

.....

Which bulb is the brightest?

.....

## Page 43 - Kirchhoff's voltage law:

Here are the circuit diagrams for four lighting circuits.

Use Kirchhoff's voltage law to fill in the missing voltages:

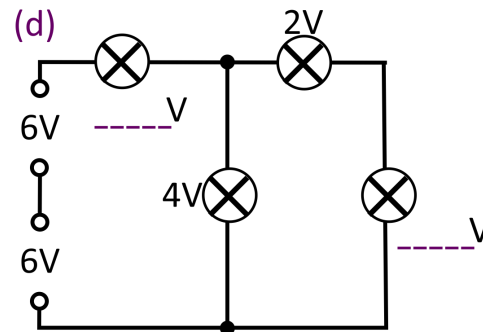
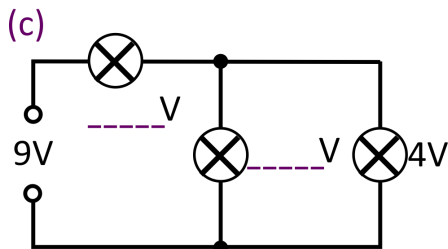
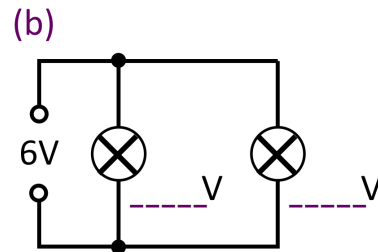
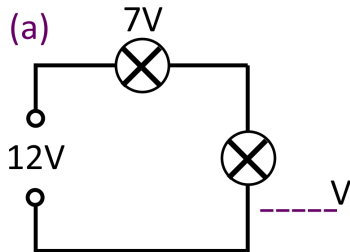

## Page 44 - Kirchhoff's current law:

In the three lighting circuits shown below, some of the currents are given. Use Kirchhoff's current law to fill in the missing currents.

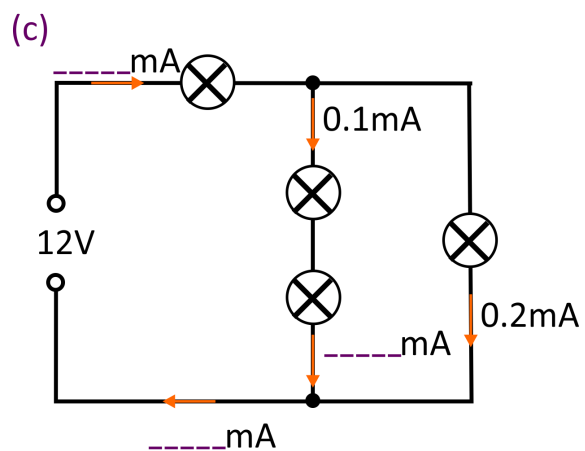
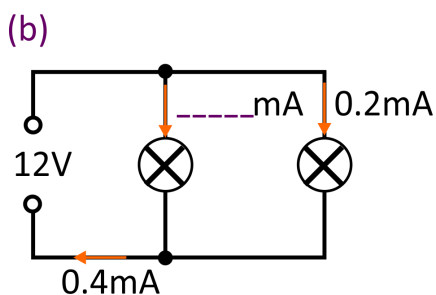
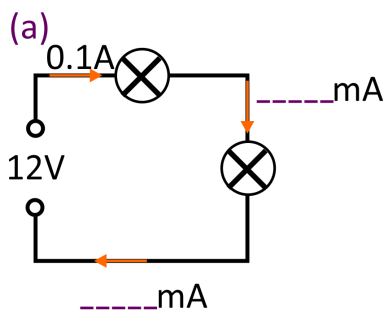

Page 45- Resistance - 1:

We control the flow of electricity using a **resistor**.

What effect does adding the resistor have on the brightness of the bulb?

.....

What does this tell you about the effect of adding the resistor on the current?

.....

Page 47- Ohm's law - 1:

**Ohm's law:**

- relates the current, **I**, through a resistor, **R**, to the voltage, **V**, across it;
- results in the formula: **V = I x R** ( or **I = V / R**, or **R = V / I**)  
using either volts / amps / ohms or volts / milliamps / kilohms;
- applies only when the temperature of the conductor stays steady.

Component	Power supply voltage	Voltage across component	Current in mA	Resistance in kΩ
1kΩ resistor	12V			
	6V			
12V 0.1A bulb	12V			
	6V			

Write down the resistance of the 1kΩ resistor in ohms ..... Ω.

Page 48- Ohm's law - 2:

Combination of two lamps	Voltage across component	Current in mA	Resistance in kΩ
In series			
In parallel			

With the lamps **in series**, what is the voltage across each lamp? ..... V.

From the previous activity, what is the resistance of a bulb at this voltage? ..... Ω

Comment on the resistance of the series combination compared to this value.

.....

With the lamps **in parallel**, what is the voltage across each lamp? ..... V.

From the previous activity, what is the resistance of a bulb at this voltage? ..... Ω

Comment on the resistance of the parallel combination compared to this value.

.....



## Page 49 - Measuring resistance - 1:

Resistance:

- is a hindrance to the flow of electrons around the circuit;
- removes energy from each electron as it moves through the resistor;
- converts this energy into heat;
- is measured in units called 'ohms' (symbol - ' $\Omega$ ') or kilohms ( $k\Omega$ ), by an ohmmeter. (1 kilohm = 1 000 ohms.)

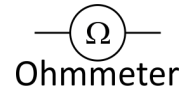

**When using a multimeter to measure resistance, the component must be removed from the circuit first!**

Using a multimeter to measure resistance:

- Plug one wire into the black '**COM**' socket and the other into the red ' $\Omega$ ' socket.
- Turn the dial to select a resistance range, such as  $200k\Omega$  (or a range higher than the reading you are expecting.)
- Make sure that the component is not connected to any other.
- Plug the wires into the sockets at the ends of the component.
- Switch on the multimeter when you are ready to take a reading.
- Now select a lower range if that is appropriate.

## Page 50 - Measuring resistance - 2:

Resistance of Locktronics resistor carrier = .....  $\Omega$ .

Resistance of 'home-made' resistor = .....  $\Omega$ .

Resistance of 12V 0.1A bulb at room temperature = .....  $\Omega$ .

What happens to the resistance of the bulb filament as the temperature rises?

.....

## Page 51 - Resistivity - 1:

The resistance of a wire depends on three factors:

- its length;
- cross-sectional area;
- the resistivity of the material it is made from.

It is measured in units called  $\Omega$  m (ohm metres).

Page 52 - Resistivity - 2:

Complete the table by adding your resistance measurements:

Sam- ple	Material	Length L in m	Cross-section A in mm <sup>2</sup>	Resistance R in Ω
A.	Nichrome	0.5	0.075	
B.	Nichrome	0.25	0.075	
C.	Nichrome	0.5	0.21	
D.	Constantan	0.5	0.075	

Comparing A and B:

Resistance ..... (increases / stays the same / decreases) as length increases.

Comparing A and C:

Resistance ..... (increases / stays the same / decreases) as cross-section increases.

Comparing A and D:

Resistance ..... (increases / stays the same / decreases) as resistivity increases.

Page 53 - Resistivity - 3:

Voltage, V, across nichrome sample = ..... V

Current, I, through nichrome sample = ..... mA

Resistance of nichrome sample =  $V / I$  = ..... kΩ

Resistivity  $\rho = \frac{R \times A}{L}$  where R is the resistance of the sample.

Resistivity of nichrome = ..... Ωm

Voltage, V, across constantan sample = ..... V

Current, I, through constantan sample = ..... mA

Resistance of constantan sample =  $V / I$  = ..... kΩ

Resistivity of constantan = ..... Ωm

## Page 54 - Electrical safety:

Our bodies can sense electric currents as small as 1mA.

A current of 10 mA DC can cause muscle contractions which mean that the victim cannot release the electrified object.

The voltage required to deliver these currents depends on a number of factors including the electrical resistance of the human body.

This, in turn, depends on factors like:

- the presence of sweat on the skin;
- the hydration level of the body - 45 to 70% of the weight of the body is water;
- the body fat content;
- where on the body the electrical contact occurs:
  - skin has a high resistance unless it has cuts or blisters;
  - current flowing from hand to foot experiences more resistance than current flowing from one finger to the next.

The resistance of the human body is typically between 1k $\Omega$  and 100k $\Omega$ .

Safety devices :

### **Fuses and circuit breakers:**

protect the appliance and the wiring connecting it, but **NOT** the user!

A fuse may happily pass a 10A current without 'blowing'.

A human body would not be happy with a current of 10A!

The **RCD** (residual current device):

compares the current it supplies **to** the appliance with the current, which flows back **from** the appliance.

An imbalance might indicate a fault, such as an electric current flowing to earth through the user. The RCD 'trips', shutting off the electricity supply to the appliance and the user.

## Page 55 - The fuse:

In a 'short-circuit', worn or damaged insulation allows wires to touch, large currents can flow, causing a lot of heat.



One solution is the fuse - a short length of wire with a low melting point, which acts as the weak point in the circuit. A large current flowing through it heats it so much that it melts, breaking the circuit and stopping the current before it causes damage.

In the UK, mains '13A' plugs contain cartridge fuses, with ratings of 3A, 5A and 13A.



### Calculating fuse values:

Use the formula  $P = I \times V$  (or  $I = P / V$ ) to work out the normal appliance current,  $I$ . Then we choose a fuse value just greater than this.

Calculate the normal current and then choose the best fuse rating for the following:

Appliance	Power rating (W)	Normal current (A)	Fuse
Reading lamp	60		
Kettle	2000		
Fire	3000		
Vacuum cleaner	1200		

## Page 56 - The circuit breaker:

The circuit breaker switches off the current when it senses a fault.

Like the fuse, it protects the appliance and the wiring connected to it.

However, a fuse must be re-wired or replaced before normal operation can resume. The mcb can be reset, usually by pressing a reset button or operating a switch.



Trip current for circuit breaker = .....A

## Page 57 - The RCD:

A faulty electrical appliance might give the user an electric shock, with a current,

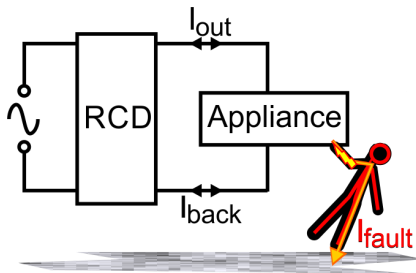

$I_{\text{fault}}$ , flowing to earth through the user. The **RCD** compares the current ( $I_{\text{out}}$ ) flowing **to** with that ( $I_{\text{back}}$ ) returning **from** an appliance. If the difference ( $I_{\text{out}} - I_{\text{back}}$ ) reaches a set value (typically 30mA), the RCD 'trips', shutting off the electricity supply.

The RCD 'trips' when the currents  $I_{\text{out}}$  and  $I_{\text{back}}$  differ by around 30mA or more. In this investigation, this comes from allowing some current to bypass the RCD. Explain how this imbalance is created:

.....

.....

.....

.....

The fault current which caused the RCD to trip = ..... mA

## Page 58 - Earthing:

Sometimes, part of an electrical appliance, such as the outer metal casing, can become 'live' (wrongly connected to the mains electricity line cable.) Anyone touching this receives an electric shock which can cause serious injury or death.

'Earthing' is the procedure used to ensure that when part of an appliance becomes 'live', a large current flows causing a fuse to blow, or circuit-breaker or RCD to trip. In this way, the user is protected from electric shock. A cable, the 'earth' lead, connects vulnerable parts of the appliance to the earth, or ground.

The diagram shows one way to do this, called the TN-C-S system. All earth leads are connected to the incoming neutral lead, usually inside the electricity supplier's fuse, where the electricity supply cables enter the building.

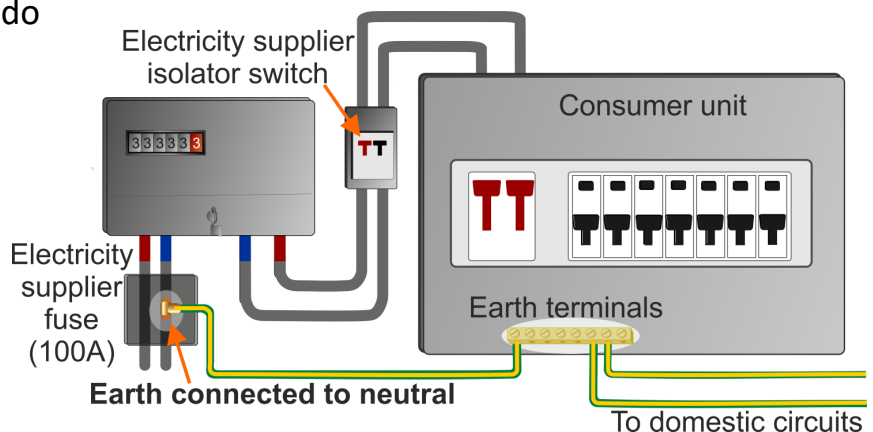

## Page 59 - The energymeter:

### Energy:

- comes from sources such as fossil fuels, the Sun, nuclear fission;
- appears in many forms, heat, light, sound, electricity etc.;
- is measured in units called joules (J) or kilowatt-hours (kW-h).

### Power:

- measures how much energy we use (or convert) each second;
- is measured in watts (W), or kilowatts (kW). (1 kilowatt = 1 000 watts.)

For example:

- a 100W lamp is much brighter than a 40W lamp - it converts more electrical energy into light each second;
- a 3kW heater generates three times as much heat as a 1kW heater.

## Page 60 - Measuring power:

Power consumed by one lamp = .....

Power consumed by two lamps in parallel = .....

Power consumed by two lamps in series = .....

Comment on these results:

.....  
.....

## Page 61 - Energy and power:

To calculate electrical power, use the formula:

$$P = I \times V \quad (\text{i.e. power} = \text{current} \times \text{voltage.})$$

Alternatively:  $I = P / V$  or  $V = P / I$

Example:

Calculate the power rating of a bulb taking a current of 0.25A from the 240V mains.

$$\text{Power} = \text{current} \times \text{voltage} = 0.25 \times 240 = 60\text{W}.$$

Use this formula to complete the following table:

	Power	Voltage	Current
A		250V	4A
B	750W	250V	
C	48W		4A
D		12V	200mA

## Page 62 - Electromagnetism - 1:

We map magnetic fields using 'lines of force', also called 'flux lines'.

The magnetic force is strongest where they are packed most tightly.

A line of force is the path that a free north pole would follow.

A free south pole would go in the opposite direction.

In reality, a **single** magnetic pole, whether 'north' or 'south' cannot exist alone.

In practice, a plotting compass needle points along a line of force. 'Lines of force' don't exist either - they are just tools used to illustrate features in a magnetic field.

Use the your results to sketch the magnetic field around the electromagnet.

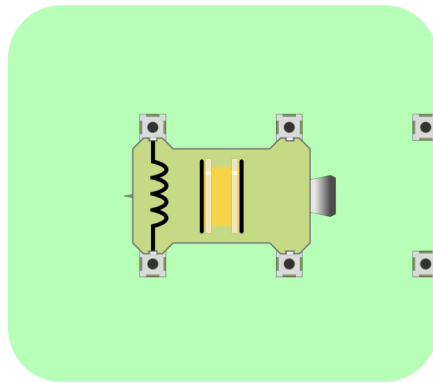

## Page 63- Electromagnetism - 2:

When a magnetic field moves across a conductor, it generates a voltage.

It can be shown that this voltage:

- has a **size** that depends on the speed of movement and the number of turns of wire in the coil;
- a **direction** that depends on the direction of motion.

**Fleming's Right-hand Rule** (also known as the *dynamo rule*):

predicts the generated current direction, using the **right**-hand to produce the gesture shown:

With the **F**ore finger in the direction of the magnetic **F**ield (i.e. North pole to South pole,) and the thu**M**b in the direction of the **M**otion, the **C**entre finger points in the direction of the resulting **C**urrent.

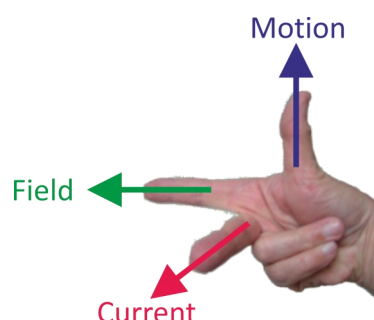

## Page 64- Generating electricity - 1:

The requirements for generating electricity using electromagnetism are:

- a magnetic field;
- a conductor;
- relative motion between them.

The diagram represents a single coil of wire, rotating in a magnetic field. As one side moves up, the other side moves down, but both in the same magnetic field.

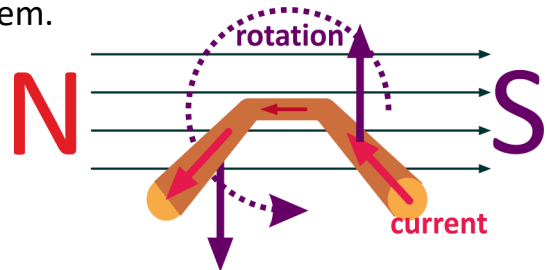

The currents induced in the two sides flow in opposite directions, one into the

paper, the other out of it. In other words, the induced current flows around the coil.

Apply Fleming's Right-hand rule to check the current direction in the two sides of the coil.

Electrical connection to the rotating coil can be made in two ways using:

- a commutator to produce a DC output;
- slip-rings to give an AC output.

Explain the difference in the construction of slip-rings and commutators.

.....

.....

.....

## Page 65- Generating electricity - 2:

Most electricity is generated by a rotating magnetic field inside a stator containing coils of wire. This magnetic field could be produced by rotating a magnet. However, more often it is produced by a rotating electromagnet, using a small DC current from an 'exciter'.

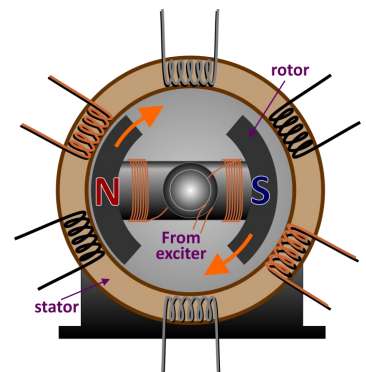

The diagram shows the basics of a three-phase alternator, which generates three AC outputs, out of step with each other, as the graph shows.

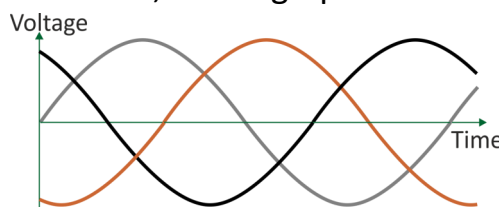



Page 66 - Transformer - 1:

One huge advantage of generating electricity as AC is that it allows the use of transformers to change the ‘format’ of the electricity supply. They change from high to low voltage, or the reverse, without losing much energy as heat in the process.

Page 67 - Transformer - 2:

In the primary coil (electromagnet), the magnetic field builds up and collapses in step with the AC current. This provides the motion needed to generate electricity in the other coil, called the secondary.

What is ‘ferrite’? .....

What is the role of the ferrite rod in this activity?  
.....

Is the voltage generated in the secondary AC or DC? .....

Page 68 - Step-down transformer:

The strength of the magnetic field in the primary depends on factors like:

- the number of turns in the primary coil,
- the current flowing through it and so the voltage applied to it.

The voltage generated in the secondary coil depends on factors like:

- the strength of the magnetic field generated by the primary;
- the number of turns of wire in the secondary coil;
- how effectively the magnetic field of the primary links with it.

In a step-down transformer, the primary coil, the one supplied with AC power, has more turns of wire than the secondary, the one that generates the output voltage.

Record your measurements in the following table:

Use them to answer these questions:

What is ‘stepped-down’ in this transformer? .....

What is ‘stepped-up’ in this transformer? .....

Step-down results	
V <sub>P</sub>	
V <sub>S</sub>	
I <sub>P</sub>	
I <sub>S</sub>	

Use the formula  $P_{IN} = V_P \times I_P$  to calculate the power supplied **to** the transformer:

$P_{IN} =$  .....

Use the formula  $P_{OUT} = V_S \times I_S$  to calculate the power supplied **by** the transformer:

$P_{IN} =$  .....

Does the transformer step-up power? .....

Page 69 - Step-up transformer:

In a step-up transformer, the primary coil has fewer turns than the secondary.

The National Grid uses both step-up and step-down transformers. At a power station, the output voltage is stepped up (typically to 11kV or higher). By doing so, a smaller current needed to transmit a given amount of electrical power and so less energy is wasted in the transmission cables. At the substation, a step-down transformer then lowers the voltage, typically to 440V and 240 V.

In the home, step-down transformers are common, used as battery eliminators for electronic devices such as computers, televisions, mobile phones (and for Matrix Locktronics circuits!) The step-down transformer outputs an AC voltage which then needs rectification to DC and smoothing before being used as a power supply.

Record your measurements in the following table:

Step-up results	
$V_P$	
$V_S$	
$I_P$	
$I_S$	

Use them to answer these questions:

What is 'stepped-up' in this transformer? .....

What is 'stepped-down' in this transformer .....

Use the formula  $P_{IN} = V_P \times I_P$  to calculate the power supplied **to** the transformer:

$P_{IN} = \dots\dots\dots$

Use the formula  $P_{OUT} = V_S \times I_S$  to calculate the power supplied **by** the transformer:

$P_{IN} = \dots\dots\dots$

Does the transformer step-up power? .....

You should find that neither type of transformer increases power. That would amount to creating energy from nothing, which the laws of physics do not allow! They change the format from high-voltage-low-current to low-voltage-high-current, or vice-versa, to suit the application.

## Page 70 - Transformer relations:

The commercial transformer was a big improvement over the first transformer. The two coils sitting side by side are linked by a more elaborate core, which threads through the centre of the coils, and wraps around the outside too. This results in a much more effective magnetic field linkage between the coils. between the secondary coil, and the magnetic field generated in the primary.

What the results show:

- The ratio  $V_P : V_S$  for both types of transformer is related to the turns ratio.
- The transformer relation says that for an ideal transformer:

$$V_P / V_S = N_P / N_S$$

where  $N_P$  is the number of turns on the primary coil;  
and  $N_S$  is the number of turns on the secondary coil.

In general terms:

- a step-up transformer 'steps up' the voltage (here, virtually doubles it,) but 'steps down' the current - the primary current is much greater than the secondary.
- a step-down transformer 'steps down' the voltage, but it delivers the same secondary current as before for a much smaller primary current.
- For an ideal transformer (100% efficient):

$$P_{IN} = P_S$$

where  $P_{IN}$  is the power delivered to the primary,  
and  $P_{OUT}$  is the power delivered by the secondary;

and  $I_S / I_P = N_P / N_S$

### **Verdict:**

There is nothing magical about the transformer. It changes the 'format' of the electricity supply, but at a cost in terms of energy wasted.

# Instructor Guide

## About this course

### Introduction

The course is essentially a practical one. Where possible, practical implications and applications of the theory are highlighted to make the course appear more relevant to the students.

Locktronics equipment makes it simple to construct and test electrical circuits. Electrical wiring diagrams are used as well as conventional circuit diagrams.

A Student Handbook is included to give students a concise record of their studies.

### Aim

The course introduces students to the basic concepts used in domestic and industrial electrical installation.

It covers much of the content of the City and Guilds Level 2 Diploma in Electrical Installations, building on knowledge acquired on introductory courses such as the Matrix LK 4098 “Electrical wiring 1” course and forms the basis for further study of this topic.

### Prior Knowledge

The student should have basic mathematical skills sufficient to calculate a required quantity from a given formula. No manipulation of formulae is expected.

They should have followed the Matrix LK 4098 “Electrical installation 1” course, or should have equivalent knowledge and experience of electricity and electrical wiring installations.

### Progression

Further content of the City and Guilds Level 2 Diploma in Electrical Installations is covered in the Matrix ‘Three Phase Systems’ course, LK2686. This includes manipulating phase, star and delta configurations, power factor and its correction and the implications of balanced and unbalanced loads.

### Using this course:

The experiments in this course should be integrated with relevant teaching to support the theory behind them, and reinforced with practical examples and assignments.

The activities should be printed / photocopied / laminated, preferably in colour, for the students’ use. They are unlikely to need their own permanent copy of them. The Student Handbook should be made available at the outset, so that students can complete it with their measurements and observations as they progress through the course and then keep it for their records.

The format of the course encourages self-study, with students working at a rate that suits their ability. The instructor should monitor that students’ understanding keeps pace with progress through the worksheets. One way to do so is to ‘sign off’ each activity, as a student completes it, and in doing so have a brief chat with the student to assess grasp of the ideas involved in the exercises it contains.

### Time allocation:

It should take students around 20 hours to complete the activities. A similar length of time will be needed to support the learning that takes place as a result.

## Learning Objectives

On successful completion of this course the student will be able to:

- distinguish between DC and AC power;
- interpret a voltage / time graph produced by an oscilloscope;
- give two reasons why, on the National Grid, AC power is preferred to DC power;
- name two common sources of AC and DC power;
- explain what is meant by the following terms, applied to an AC signal:
  - peak voltage;
  - peak-to-peak voltage;
  - periodic time;
  - frequency;
- state and use the formula linking periodic time and frequency;
- explain the meaning of the term 'r.m.s.' applied to an AC sinusoidal signal;
- state and use the formula linking r.m.s. and peak voltages for an AC sinusoidal signal;
- describe how to distinguish between electrical conductors and insulators;
- recognise that most metals are good conductors;
- identify the circuit symbols for common electrical components;
- interpret simple circuit diagrams;
- identify the current path in simple series and parallel circuits;
- trace the current path in a simple electrical installation diagram;
- state that an electric current can have a heating effect and name three applications of the effect;
- state that an electric current can have a magnetic effect and name three applications of the effect;
- explain the motor effect as the interaction between the magnetic field of a permanent magnet and that of a current-carrying wire;
- use Fleming's Left-hand rule to predict the direction of motion of a current-carrying wire in a magnetic field;
- use Fleming's Left-hand rule to predict the direction of rotation of a single turn coil in a magnetic field;
- state that an electric current can have a chemical effect and name three applications of the effect;
- identify a series connection of components;
- use the brightness of lamps connected in series to justify the statement that the same current flows in all parts of a series circuit;
- predict what will happen to the current when a fault occurs in a lamp in a series circuit;
- identify a parallel connection of components;
- state that the sum of the currents in the branches of a parallel circuit is equal to the current leaving the power supply;
- predict what will happen when a fault occurs in one branch of a parallel circuit;
- apply the rules for series and for parallel combinations to a circuit containing a mixture of these connections;
- state that filament lamps are mass-produced and, as a result, may not have identical characteristics;
- explain why, in a domestic installation, lamps are usually connected in parallel whereas controls such as fuses and thermostats are connected in series with the device they manage;
- build a circuit using two changeover switches to control a lamp from two locations, such as the top and bottom of a set of stairs;
- build a circuit using two changeover switches and an intermediate switch to control a lamp from three locations;
- recognise the circuit symbols for a voltmeter, an ammeter and an ohmmeter;
- describe 'voltage' in terms of energy lost or gained as a current flows through a component;
- set up a multimeter to measure the voltage across a component;
- state that the voltages across the components in a series circuit add up to the power supply voltage;
- state that components connected in parallel will have the same voltage across them;
- apply these rules to a circuit containing both series and parallel connections;

*continued on the next page...*

## Learning Objectives - continued from previous page...

On successful completion of this course the student will be able to:



















- describe 'current' in terms of the number of electrons passing any point in the circuit each second;
- set up a multimeter to measure the current through a component;
- apply the rules for current in series components and in parallel components to a circuit containing both series and parallel connections;
- state Kirchhoff's voltage law and use it to deduce the voltage across a component in simple circuits containing series and parallel connections;
- state Kirchhoff's current law and use it to deduce the currents flowing in parts of simple circuits which contain both series and parallel connections;
- describe what is meant by 'electrical resistance' and its effect on the current flowing in a circuit;
- state and use the formulae derived from Ohm's law;
- state that adding resistors in series increases the total resistance of the components whereas adding them in parallel reduces their total resistance;
- set up a multimeter to measure the resistance of a component;
- state the three factors which determine the resistance of a conductor;
- explain what is meant by the term 'resistivity';
- take electrical measurements needed to calculate resistivity;
- state and use the formula to calculate the resistivity of a substance;
- describe how a fuse protects a circuit from excessive current;
- describe the difference in the functions of a fuse, circuit breaker and RCD device;
- state and use the formula to calculate the 'normal' current in a device, given its power rating and operating voltage and hence deduce the best value for the cartridge fuse for that device ;
- state the full name for a mcb and give one advantage of using it compared to using a fuse;
- state three factors which affect the resistance of the human body;
- explain why a fuse or a circuit breaker may not protect the user when a fault develops in an appliance;
- measure the 'trip' current for a circuit breaker;
- state the full name for a RCD and explain how it monitors the state of a circuit;
- measure the 'trip' current for a RCD;
- describe the principles of earthing an appliance;
- describe the TN-C-S earthing system;
- distinguish between the terms 'energy' and 'power';
- use an energy meter to measure the energy converted in a low-voltage appliance;
- compare the energy consumption of two identical lamps connected in series and then in parallel;
- state and use the formula to calculate the power rating of an appliance given the current flowing through it and the voltage across it;
- explain the significance of magnetic lines of force as a means to describe a magnetic field;
- use a plotting compass to map a magnetic field;
- demonstrate how to generate an electric current using a coil of wire and a magnet;
- use Fleming's Right-hand rule to predict the current direction when a conductor moves in a magnetic field;
- apply Fleming's Right-hand rule to find the direction of current flow in the arms of a coil of wire rotating in a magnetic field;
- describe, in outline, the structure of a three-phase generator;
- describe, in outline, the structure of a simple transformer and the role of the ferrite core;
- explain why a transformer works on an AC supply and not on a DC supply;
- identify the factors that determine the strength of the magnetic field in the primary coil of a transformer;
- identify the factors that determine the size of the voltage generated in the secondary coil of a transformer;
- distinguish between a step-up and a step-down transformer in terms of structure and performance;
- state and use the transformer relation to predict the size of the voltage generated in the secondary of a given transformer.



## What the student will need:

To complete the course, the student will need the following equipment:

1	HP2045	Shallow tray
1	HP2666	DC power supply
1	HP3728	AC power supply
2	HP4039	Tray lid
1	HP5540	Deep tray
2	HP7750	Daughter tray foam cut out
1	HP8600	Crash foam
2	HP9564	62mm daughter tray
1	LK2340	AC voltage source carrier
5	LK2346	MES bulb 12V, 0.1A
1	lk4100	12 ohm resistor
1	LK4123	Transformer, 2:1 turns ratio
1	LK4893	Hand-cranked generator
1	LK5202	Resistor, 1k, 1/2W, 5% (DIN)
1	LK5203	Resistor, 10k, 1/4W, 5% (DIN)
1	LK5208	Resistor - variable, 250 ohm
1	LK5243	diode power
16	LK5250	Connecting Link
5	LK5291	Lampholder carrier
1	LK5570	Pair of 4mm to croc clip leads
1	LK5603	Lead - red - 4mm to 4mm stackable
1	LK5604	Lead - black - 4mm to 4mm stackable
1	LK5609	Lead - blue - 4mm to 4mm stackable
1	LK6203	2200 capacitor
1	LK6207	Switch, push to make
2	LK6208	Switch, changeover, metal strip
3	LK6209	Switch on/off
1	LK6482	Fleming's motor rule apparatus
1	LK6632	Switch, reversing, toggle
1	LK6841	LED bulb MES white
1	LK7483	Transformer with retractable ferrite core
1	LK7928	RCD carrier
1	LK7936	Universal component carrier
1	LK8150	Nichrome Wire Carrier, 0.075 x 500mm
1	LK8152	Nichrome Wire Carrier, 0.075 x 250mm
1	LK8154	Nichrome Wire Carrier, 0.21 x 500mm
1	LK8156	Constantan Wire Carrier, 0.075 x 500mm
1	LK8275	Power supply carrier with battery symbol
1	LK8623	Circuit breaker 1A carrier
1	LK8900	Baseboard
1	LK9070AP	EMM Accessories Pack
1	LK9998	400 turn coil carrier

Page	Notes for the Instructor	Timing														
<p>3 Introduction</p>	<p>The course aims to prepare students for Unit 202 - “Principles of Electrical Science”, part of the City and Guilds Level 2 Diploma in Electrical Installations . It follows on from the Level 1 course (LK4098). It uses both AC and DC power supplies so that the students is familiar with both and includes a comparison of their performance. By default, activities use the AC supply, as in most domestic and industrial installations. At times, the DC power supply is used either because of the instrumentation, or the nature of the investigation.</p> <p>The layouts show the student how to build the systems and include an appropriate type of power supply carrier, sometimes AC and sometimes DC. Often, this choice is optional and icons are used to identify which type of power supply can be used.</p> <p>Other icons show the kind of activity being undertaken:</p> <table border="1" data-bbox="432 835 1166 1357"> <thead> <tr> <th>Icon</th> <th>Significance</th> </tr> </thead> <tbody> <tr> <td></td> <td>Content gives information about electricity, or explains some terminology</td> </tr> <tr> <td></td> <td>Practical activity</td> </tr> <tr> <td></td> <td>Relates the current activity to jobs in the industrial / domestic realm</td> </tr> <tr> <td></td> <td>Open-ended activity where the students designs the activity</td> </tr> <tr> <td></td> <td>Health and Safety related issue</td> </tr> <tr> <td></td> <td>Activity involves a formula or calculation</td> </tr> </tbody> </table> <p>Each activity includes the Unit 202 Learning Objective which it addresses.</p>	Icon	Significance		Content gives information about electricity, or explains some terminology		Practical activity		Relates the current activity to jobs in the industrial / domestic realm		Open-ended activity where the students designs the activity		Health and Safety related issue		Activity involves a formula or calculation	
Icon	Significance															
	Content gives information about electricity, or explains some terminology															
	Practical activity															
	Relates the current activity to jobs in the industrial / domestic realm															
	Open-ended activity where the students designs the activity															
	Health and Safety related issue															
	Activity involves a formula or calculation															
<p>4 Circuit training</p>	<p>The first activity is marked ‘optional’.</p> <p>Students who are familiar with the Locktronics system can omit this.</p> <p>For new students, the activity is important, partly in building confidence - many people have serious misgivings about anything electrical - they can’t see how it works, worry about electric shocks etc., partly to impart enjoyment and challenge and partly to introduce the Locktronics kit.</p> <p>In the Student Handbook, the students complete a table by relating the Locktronics components to ‘real-life’ counterparts that students will meet in the work-place.</p> <p>Throughout the course, activities are designed to mirror the tasks and experiences that the students will find in their working lives.</p> <p>The instructor should add anecdotes from their experience to enrich these activities.</p>	<p>15 - 20 mins</p>														

Page	Notes for the Instructor	Timing
5 Power Supplies - 1	<p>This section introduces the two types of electrical power, AC and DC, through voltage / time graphs. Some students may not have sufficient mathematical experience to appreciate their significance. In that case, the instructor may need to spend time working through other examples.</p> <p>The section also mentions that oscilloscopes can be used to produce these graphs. The instructor could demonstrate this, though students themselves are not expected to have any understanding or expertise in using an oscilloscope at this stage.</p>	10 - 15 mins
6 Power Supplies - 2	<p>This section provides outline information about the role of the power supply, e.g. the plug-top devices used in these activities or the National Grid in domestic installations and explains the need for both.</p> <p>At this stage, the student needs to know little about the process of electricity generation, but the instructor may wish to point out that the alternator, an AC generator, whether driven by steam, water, wind or internal-combustion engine, is usually more efficient than the equivalent DC generator.</p> <p>Transformers will not work on DC. They have the ability to step-up or step-down voltage and current very efficiently.</p> <p>Both of these factors argue in favour of generating electricity in AC form. The remainder of this page looks at common sources of AC and DC power and mentions that each can be converted into the other by using appropriate circuitry.</p> <p>The instructor could support this section using examples of electricity sources - batteries, solar cells, alternators etc.</p>	10 - 15 mins
7 AC versus DC - 1	<p>The activity shows that DC and AC power supplies can perform the same task - lighting a lamp. This will eventually lead to a discussion of the r.m.s. value of an AC supply, as the DC equivalent voltage that produces the same effect, and finally as a mathematical formula. (This works only for sinusoidal AC signals, but the students need not be aware of this.)</p> <p>This activity looks at the first part of the task - identifying two bulbs that have the same brightness, i.e. are roughly identical.</p>	20 - 30 mins
8 AC versus DC - 2	<p>This continues the task spelled out in the previous activity - to show that DC and AC power supplies can perform the same task.</p> <p>The instructor may wish to point out at this stage that the average AC voltage is zero - it spends equal times at positive and negative values. The peak value of the AC voltage is similarly inappropriate as a realistic measure of the effect of an AC supply. Most of the time, the AC voltage is smaller than that peak value.</p> <p>Here, one lamp is driven off a 12V DC supply and the other off a variable AC supply (using the 250Ω 'pot' to vary the output of the AC supply.) When the two bulbs are judged to be the same brightness, the outputs of the DC and (variable) AC power supplies are doing the same job.</p>	20 - 30 mins

Page	Notes for the Instructor	Timing
<p>11 Conductors and Insulators</p>	<p>This activity divides a range of materials into two broad categories - electrical conductors and electrical insulators. This categorisation is too rough, as some materials conduct (or insulate) better than others. However, it is a start!</p> <p>In effect, it uses the lamp and power supply as a continuity tester. It may be worth the instructor pointing this out, as later in the course, students will meet similar devices.</p> <p>If the instructor wishes to streamline this activity, each group of students could be given only three or four materials. The results of all the groups can then later be pooled.</p> <p>The instructor may wish to analyse the results to point out that most metals are good conductors, whereas non-metals are insulators. A good topic for discussion is whether water is a conductor. The key is to distinguish between pure (i.e. de-ionised) water - an insulator - and impure, e.g. tap water or sea water, that definitely conduct.</p>	<p>20 - 30 mins</p>
<p>12 Circuit Diagrams</p>	<p>The students meet the first of a number of forms of circuit diagram. It is the one in widespread use in the electronics industry and the one used by the Locktronics system.</p> <p>Students should realise the importance of using standard notation for circuit diagrams as a short-hand way to represent wiring installations.</p>	<p>10 - 15 mins</p>
<p>13 Current path - 1</p>	<p>The activity begins with a reminder of some of the vocabulary being used.</p> <p>The aim is partly to continue confidence-building and partly to embed the notion of a complete circuit. The orange line on the diagram shows the path taken by the current around the circuit. The use of double-headed arrows indicates that it is AC current.</p> <p>The student sees the effect of 'breaking' the circuit, by removing a connecting link and by unscrewing a bulb, reinforcing the need for a complete circuit.</p> <p>The instructor could contrast this situation with a domestic gas installation, where only one pipe is needed rather than a circuit. Nothing returns to the gas supplier! Unlike electricity, gas is burned!</p> <p>Road traffic offers a number of analogies for 'breaking' the circuit - road works, accidents, congestion. The instructor may wish to expand on these with the class.</p> <p>The activity invites the student to create other 'shapes' with the caveat that there should be no junctions. Parallel circuits behave differently, as later activities will show.</p> <p>The instructor should warn about the need to avoid short-circuits In the Locktronics situation, these are of no significance - the power supply simply shuts down for the duration of the short-circuit. In 'real-life' circuits, the consequence could be far more serious - a fire or electric shock.</p>	<p>15 - 25 mins</p>

Page	Notes for the Instructor	Timing
<p>9 Measuring AC</p>	<p>This section identifies common measurements relating to AC signals - 'peak', 'peak-to-peak', 'periodic time' and frequency. These are applied to the voltage / time graph for an AC signal. Some students will need support in understanding the graph and extracting data from it.</p> <p>To assess students' understanding, the instructor could have other graphs available for students to work on, or could reverse the process by asking students to sketch curves that meet a given specification, in terms of peak voltage and period.</p> <p>The frequency formula can be introduced by comparing it to other periodic events:                      "If the time period between the arrival of buses is 30s, how many arrive per minute?",                      "You are standing on a beach. Ten waves reach the shore every minute. What is the time interval between waves?" etc.</p> <p>The SI unit of frequency is the hertz (Hz). An older equivalent is 'cycles per second', which better explains what 'frequency' means.</p> <p>The Student Handbook includes an exercise to reinforce these concepts.</p>	<p>15 - 20 mins</p>
<p>10 AC and DC again</p>	<p>The section starts by listing issues relating to the use of AC power. The instructor could make the point that, even though AC has an average voltage of zero, it can still kill you! In other words, average voltage is not a useful measure in assessing danger!</p> <p>It would make sense for 'electricians-to-be' to focus only on AC in these activities . However, multimeters often offer more measurement ranges for DC. The 'energy meter', which students may see later used for energy and power measurement, works only on DC.</p> <p>As a result, both forms of power supply are used within the activities. Sometimes, the activity must use the DC power supply. The icon that accompanies each activity indicates which should be used or where there is a choice.</p> <p>The section adds detail to the notion of 'r.m.s.' The graph compares an AC power signal with a DC equivalent. It then introduces the formula linking r.m.s. and peak values. It is obviously important to distinguish between the two and to know which is being used in domestic electricity. In the UK, we talk about '240V AC' but this is the r.m.s. value of voltage.</p> <p>In the Student Handbook, students are tasked with calculating the peak voltage of this supply as well as using the formula in other examples. The instructor should assess how well students are able to tackle these and similar calculations.</p>	<p>15 - 20 mins</p>

Page	Notes for the Instructor	Timing
14 Current path - 2	<p>This makes the important link between electrical theory and practice.</p> <p>The previous activity involved circuits made from carriers having single wires, whereas domestic lighting installations use 'twin-and-earth' cables to reduce the number of wires involved (and for mechanical protection of the current-carrying wires). The instructor should check that students recognise this link.</p> <p>The students are given the task of tracing the current path through this circuit. After allowing the students time to do this, it could be summarised as a class exercise.</p> <p>The instructor could also have an example wired up so that students can compare the diagram with the 'real thing'.</p>	15 - 25 mins
15 Effects of electric currents - 1	<p>The student is required to know the three effects which can accompany an electric current - heating, magnetic and chemical. This activity looks at the first.</p> <p>To begin with, the student feels the glass envelope of a filament lamp. As a later section points out, the filament glows yellow-hot because it is heated to a very high temperature by the current.</p> <p>Next, the student makes an electrical heater by clamping a few strands of steel wool in the universal component carrier. If too many strands are used, the resulting current may be so high that it shuts down the power supply and nothing is seen. If too few are used, then they might heat up sufficiently to burn and melt. Getting the right number is a matter of practice.</p>	20 - 30 mins
16 Heating effects	<p>This page highlights some of the applications of electrical heating. This could be the focus of a number of assignments - recent developments in electrical lighting, home heating, electrical safety etc. The reverse, the thermocouple is mentioned. An example to show the students would be helpful.</p>	10 - 15 mins
17 Effects of electric current - 2	<p>This activity requires a DC power supply to ensure that the resulting magnetic field is steady. The lamp has two functions - to indicate that a current is present, and to limit that current to a value that does not over-heat the coil or cut out the power supply. If the student notices no effect on the compass, it may be that the baseboard is oriented in the wrong compass direction, an unlucky event! Rotating the board through 90<sup>o</sup> should cure this.</p> <p>The student waves a magnet near the plotting compass to illustrate that the current-carrying coil has the same effect as a magnet. With the eventual study of transformers in mind, the student tests to see whether a 'core' of magnetic material, the steel nail in this case, intensifies the magnetic field.</p>	20 - 30 mins

Page	Notes for the Instructor	Timing
18 Magnetic effects	<p>The focus here is the electric motor, a widespread application of electro-magnetism. It is present in a host of domestic appliances, some of which also include heaters. Once more, this is a rich source of assignments.</p> <p>Other applications are listed and the instructor may wish to develop themes relating to these or introduce others. Mention of the circuit-breaker can be linked back to work done on the fuse.</p>	15 - 25 mins
19 Motor effect - 1	<p>Motors abound and come in a variety of shapes and sizes. It is helpful to have a display of examples to introduce this topic.</p> <p>The experiment itself lasts only a few minutes, but the students should be allowed to 'play' with the kit until they are confident about what is happening. The instructions tell them how to reverse the magnetic field, and reverse the current direction, to see what effect these changes have.</p>	15 - 25 mins
20 Motor effect - 2	<p>Ultimately, the motor effect is pretty mysterious and relates to the properties of electrons themselves.</p> <p>It depends on the previous experience of the students as to how far the explanation on page 20 is taken. Electrons are 'magical' and their behaviour is beyond our everyday experience. For example, if an electron moves past us, we experience a magnetic field. Equally, if the electron is at rest and we move past it, the result is the same. If we move along at the same rate as an electron, we experience no magnetic field. Moving electrons are the source of all magnetic effects, even those in 'permanent' magnets, even though there is no obvious flow of electrons. It is important that they learn to use the left-hand (motor) rule to relate the direction of the force on a conductor to the current and magnetic field directions. They will need plenty of practice in applying this rule.</p>	10 - 15 mins
21 Effects of electric currents - 3	<p>The chemical effect of electricity may not be an easy one for the instructor to access. Hence, the experiment is marked 'optional'. It may be done as a demonstration or made a topic for individual research.</p> <p>The point is made that both chemistry and electrical science rely on the movement of electrons. The link between them is really inevitable. Once again, to make any effect observable, the DC power supply must be used. The lamp indicates the presence of the electric current. Close observation of the beaker shows that chemical changes are taking place.</p>	20 - 30 mins
22 Chemical effects	<p>Chemical effects of electricity are extremely useful. The topic of batteries could occupy a whole course. Rechargeable batteries are found in a huge range of appliances, from mobile phones to electric and hybrid cars. Again, rich assignment territory!</p> <p>Electrolysis and electroplating are a bit more esoteric. The instructor may choose to set these topics for individual research, or use video clips.</p>	10 - 15 mins



Page	Notes for the Instructor	Timing
<p>23 Connect in series</p>	<p>The meaning of 'series' is outlined at the top of the page.</p> <p>The circuit itself is the same as that built when looking at the need for a complete circuit and at current paths. Now the emphasis is different. It is identified as a series circuit and the activity looks at the implications.</p> <p>Perhaps the most significant property is that a break in the circuit anywhere stops the current everywhere. When Christmas tree lights were connected in series, this was the cause of the annual battle to find the faulty bulb. It is partly why lights in a house are connected in parallel, but that debate may be better held back for a couple of pages.</p> <p>The page introduces a possible problem. The success of the investigation relies on the bulbs being identical and so equally bright when the equal currents flow through them. There is a common, mistaken, belief that the current gets smaller as it goes around the circuit. If so, the bulbs would get dimmer the further they were from the start of the circuit. There is an worrying possibility that the student may see just this result, not because of the size of the current but because of the structure of the bulbs themselves. Hence, the note at the bottom of the page!</p> <p>Next, a second series circuit, containing only two lamps is created. By the end of the course, the student will know that two lamps offer less resistance than three and so the current is bigger. For now, it is enough that the student sees that this is so without worrying about resistance.</p>	<p>25 - 35 mins</p>
<p>24 Connect in parallel</p>	<p>The meaning of 'parallel' is outlined at the top of the page. The instructor could enlarge on this by discussing traffic flow. Why is a bypass seen as a solution to traffic flow through a black-spot such as an old village? Why are dual-carriageways better than single?</p> <p>The activity contrasts the behaviour of this circuit with that of the first series circuit. The procedure is the same, but the results are different. When part of the circuit is broken, the effect applies only to that part of the circuit. In a house, when one bulb 'blows', the others are unaffected.</p> <p>The instructor might point out that each of the three bulbs is connected directly to the terminals of the power supply. Each bulb is unaware of and unaffected by the others.</p> <p>Once again, students need to know that the structure of the bulbs can affect the outcome of the investigation.</p>	<p>20 - 30 mins</p>
<p>25 Series / parallel - 1</p>	<p>Very often, some components in a circuit are connected in series and some in parallel. That is the arrangement studied here.</p> <p>The first task for the student is to decide which are in series and which in parallel and to work out possible current paths - these issues are related!</p> <p>Next, the effect of breaking the circuit by unscrewing a bulb is examined. The result depends on which bulb is chosen. There is nothing new here - if it is a parallel connection, the effects are extremely local to the bulb - if in series, the effects can be more widespread.</p>	<p>20 - 30 mins</p>



Page	Notes for the Instructor	Timing
26 Series / parallel - 2	<p>Another example of mixed series / parallel connections! The aim is to give students confidence through exposure to a number of these circuits.</p> <p>The approach is slightly different in that the student is asked to predict what will happen and then test that prediction. The instructor may wish to do the first part as a 'brain-storming' session with the whole class. This allows some assessment of how well the class and individuals in it are understanding the work done so far.</p>	20 - 30 mins
27 MES bulbs	<p>As pointed out above, the investigations into series and parallel circuits require bulbs with very similar properties. This page explains why this might not be so and gives a test to decide what is going on.</p> <p>The approach is to tell the students to swap over the bulbs to see if that has an effect. If it does, then the bulbs are not identical, and should be changed - a supply of spare MES bulbs may be needed!</p>	10 - 15 mins
28 Serial / parallel applications	<p>As earlier, this section links between electrical theory and practice.</p> <p>The instructor should stress the need for understanding this link and once again could have examples wired up so that students can compare the diagrams with the 'real thing'.</p> <p>At this stage, students probably have some general awareness of fuses and thermostats and do not need detailed knowledge.</p>	15 - 25 mins
29 Staircase circuit - 1	<p>Locktronics makes it easy to set up and study the two-way lighting circuit often used to control hall and staircase lighting in the home.</p> <p>The instructor should allow time and encourage experimentation to strengthen understanding of how this is achieved. Students are asked to trace out the current path for different combinations of switch position. Their work in the Student Handbook will inform the instructor on the depth of their understanding. Again, a class demonstration using real components will help cement this understanding. The instructor must judge whether to introduce 'SPDT' at this stage.</p>	20 - 30 mins
30 Staircase circuit - 2	<p>This section follows up the work on two-way switching and shows the '2-wire control' circuit in practice. It highlights the problems associated with it - the possible safety risk and effect on RCDs. Individuals could be asked to explain these to the rest of the group to test understanding.</p> <p>The more complex concept of increased electrical interference is not mentioned. Instructors may wish to explain to a more advanced group that current carrying conductors radiate electromagnetic waves.</p> <p>In the '2-wire control' system, these can cause problems with radio and television reception and computer networks.</p> <p>In the '3-wire control' system, however, line and neutral sit side-by-side inside each cable, carrying the same current, and so the electromagnetic fields largely cancel out.</p> <p>Actual examples of changeover switches will help again. The instructor could have a low voltage circuits available so that students can compare the '2-wire' and '3-wire' systems.</p>	15 - 25 mins

Page	Notes for the Instructor	Timing
31 Staircase circuit - 3	<p>Now, the same task is investigated using the '3-wire control' system. Once again, the instructor should allow time for students to 'play' and appreciate the difference between this and the '2-wire' system studied previously.</p> <p>The instructor may need to point out why this is called '3-wire', as there appears to be only two connections between the switches. The third is provided by the 'common' connection on one changeover switch being connected directly to the 'common' contact on the other.</p>	20 - 30 mins
32 Staircase circuit - 4	<p>This section shows the '3-wire control' version in practice. Instructors should highlight the features that overcome the problems of the '2-wire control' system.</p> <p>The 'Points to note' section is there as an 'aide-memoire' for students. The notes at the bottom of the page are to help students with the task of tracing the circuit.</p>	15 - 25 mins
33 3-way control - 1	<p>This extends the previous circuit by adding an intermediate switch. The instructor should ensure that students appreciate which terminals are connected to which with each switch position. A demonstration using a continuity tester such as a multimeter may help to convince them.</p> <p>The 'Locktronics' layout is quite straightforward and allows experimentation. The real circuit is more complex! The version studied here is another example of a '2-wire control' system. The instructor could invite suggestions as to why this applies to this circuit.</p> <p>The results in the Student Handbook allow the instructor to assess a student's level of understanding on this demanding topic.</p> <p>Again, it is for the instructor to decide whether to use the term 'DPDT' for the intermediate switch.</p>	
34 3-way control - 2	<p>The treatment mirrors that for two-way switching and is equally important, and difficult, for students at this stage in their training. As before, actual examples, such as a low voltage demonstration circuit will help, as will class discussion and activities such as wiring up a 'template' and checking its operation using a low voltage supply.</p> <p>Able students, or groups of students, could be asked to create and test a 4-way control circuit using a second intermediate switch.</p>	15 - 25 mins

Page	Notes for the Instructor	Timing
<p>35 Measuring voltage - 1</p>	<p>The multimeter is one of the most feared of measuring instruments, yet probably the most useful!</p> <p>One problem is that no two models look the same. Another is that it requires knowledge to use it - an understanding of the symbols, of the importance of range and an appreciation of which sockets to use.</p> <p>It is important that they observe the instruction to select the range and connect to the sockets before they switch on. Most multimeters have an internal fuse to protect the meter when measuring current. This can 'blow' if the student makes a range selection with the meter turned on.</p> <p>The auto-ranging multimeter has both helped and hindered. It reduces the knowledge needed to use it, but masks what is going on.</p> <p>Students need practice in using multimeters and experience of a number of different types, in order to feel confident in their use.</p> <p>Voltage is simple to measure, but one of the most difficult to explain.</p> <p>Electrical current is easy to visualise - a host of little electrons bobbling along a wire. 'Voltage' is why they flow. It is related to the force that pushes them around the circuit, but isn't that force itself. It's related to the energy gained or lost by the electrons as they pass through various components in the circuit, but isn't that energy itself.</p> <p>Hence the phrase "...is a measure of..." That will have to serve for now.</p> <p>Some texts use 'e.m.f' ('electro-motive force') and p.d. ('potential difference') This adds nothing to understanding and increases complexity as the two terms are not interchangeable. For this course, and many others, 'voltage' is fine!</p> <p>Measuring voltage is easy - just connect the multimeter to the two ends of the component being investigated - in parallel with the component, in other words.</p> <p>The guidance given here includes interpretation of the symbols used and identification of the appropriate sockets.</p> <p>When other types of multimeter are used, the instructor may need to explain these to the students.</p>	<p>15 - 25 mins</p>

Page	Notes for the Instructor	Timing
36 Measuring voltage - 2	<p>A familiar circuit is set up - three lamps connected in series - to introduce voltage measurement.</p> <p>One issue that the instructor may wish to explore is that voltage is a relative measurement, involving two connections. In this regard, it is rather like measuring height. Heights are quoted relative to a known level - "...above sea-level..." "... from the floor..." Sometimes, the base level is not even mentioned as it is obvious. "My height is 1m 53cm." means from the bottom of my feet to the top of my head. It doesn't (usually) mean that I am 1m 53cm above sea level!</p> <p>Some measurements are absolute. My mass is 80kg at sea-level, on the Moon or on the floor of the house!</p> <p>The voltage measurements here can lead to Kirchhoff's Voltage Law, but that's for later. For now, they show that the power supply voltage is shared between the three lamps. It is one factor, among several, that decides how bright they are.</p>	20 - 30 mins
37 Measuring voltage - 3	<p>Measuring voltage is easy because the multimeter is connected to the two ends of the component being investigated - in parallel with the component, in other words. The guidance given here includes interpretation of the symbols used and identification of the appropriate sockets. Where other types of multimeter are used, the instructor may need to explain these to the students.</p> <p>The voltage measurements here show that the voltage across each lamp is equal to the power supply voltage, a result that comes as no surprise when looking at the way the lamps are connected to the power supply.</p>	20 - 30 mins
38 Measuring voltage - 4	<p>This activity measures relevant voltages in the mixed series / parallel circuits studied earlier.</p> <p>The student should be able to make sense of the results, bearing in mind the outcomes of the investigations into purely serial and purely parallel circuits.</p>	20 - 30 mins
39 Measuring current - 1	<p>As pointed out earlier, current is easy to visualise - hordes of electrons bobbling down a wire. As each electron carries an identical amount of negative electrical charge, current can also be described as the rate of flow of electrical charge past a point. However, measuring current is not quite so straight forward.</p> <p>In order to measure current, it must flow through the ammeter. In other words, the ammeter is connected in series with the component under investigation. That implies that the circuit must be broken to allow the ammeter to be inserted, connected to the two points created by the break.</p> <p>As for measuring voltage, the guidance includes interpretation of the symbols and identification of the sockets. Other types of multimeter may require a briefing by the instructor.</p>	15 - 25 mins

Page	Notes for the Instructor	Timing
40 Measuring current - 2	<p>The circuit has been seen before - three lamps connected in series. In order to accommodate the insertion of the multimeter (ammeter), extra connectors are placed before and after the lamps.</p> <p>The results are predictable - a series circuit, so the same current flows in all parts. Hence it is pointless to say that, for example, the current reading at 'Q' gives the current flowing the second lamp. If the same current does not flow everywhere, then where does the excess current go?</p>	20 - 30 mins
41 Measuring current - 3	<p>The process is the same, but is applied to a parallel circuit (, again, including extra connectors to facilitate taking the measurements.) The analysis is a little more complicated. At any junction, the total current flowing out of the junction is equal to the total current flowing into it. Hence, the current at point 'T' should equal the sum of the currents at 'R' and 'S'. The current at 'P' should equal the sum of the currents at 'Q', 'R' and 'S' etc.</p>	20 - 30 mins
42 Measuring current - 4	<p>Next, the same procedure is applied to a circuit containing both series and parallel connections. The two previous results still apply, but only to parts of the circuit.</p> <p>The current at 'P' equals the sum of the currents at 'Q' and 'R'. The current at 'Q' is equal to the current at 'S', and so on. The brightness of each bulb depends on the size of the current flowing through it, so the lamp above 'R' should be the brightest.</p>	20 - 30 mins
43 Kirchhoff's voltage law	<p>The earlier activities on measuring voltages in a number of lighting circuits was leading up to a look at Kirchhoff's voltage law. It is really another statement of the conservation of energy - the energy given to electrons by the power supply is lost in the bulbs as electrons flow around the circuit.</p> <p>Students will almost certainly need additional help in understanding this law. The instructor may need to explain what a 'loop' means in this context. The circuit shown has five loops, but two do not contain a power supply (the loop containing the three lamps 'P', 'Q' and 'R' and the loop containing the lamps 'Q', 'R' and 'S'). They are not considered here. The voltage across bulb 'R' is given, presumably measured. The instructor should ensure that students understand the arguments that lead to evaluating the other voltages. The Student Handbook contains a number of questions to test whether the students have grasped the concept.</p>	15 - 25 mins
44 Kirchhoff's current law	<p>A similar approach is taken in examining Kirchhoff's current law. The underlying concept is probably easier - electrons do not disappear. Like water flowing in pipes, (providing there are no leaks,) the amounts entering a junction and leaving it are the same. (The instructor could contrast this with the flow of traffic. Some vehicles crash, or park, or re-start, or get scrapped. The number entering an intersection per hour may not be the same as the number per hour leaving it!)</p> <p>Once again, the Student Handbook contains a number of questions to test understanding.</p>	15 - 25 mins

Page	Notes for the Instructor	Timing
45 Resistance - 1	<p>This exercise introduces formally the topic of electrical resistance. The universal component carrier is used to make a graphite resistor. Its effect on the brightness of a lamp is seen by inserting it in series, to control the current through the lamp, and then removing it, by short-circuiting it with a connecting wire.</p>	20 - 30 mins
46 Resistance - 2	<p>The introduction likens the effect of electrical resistance on electrons to running in mud. Increased 'friction' - electrons colliding with and losing energy to surrounding atoms - results in the generation of heat.</p> <p>The experiment follows the same procedure as the previous but this time uses the <math>10\Omega</math> resistance carrier. The actual resistance used is not important except that if it is too big, it will cut the current to such a low value that the bulb will not glow. Then the student has no way of distinguishing this situation from a break in the circuit.</p>	20 - 30 mins
47 Ohm's law - 1	<p>The section starts with an overview of Ohm's law and the formulae that derive from it. The units used in them is important - either volts, amps and ohms, OR volts, milliamps and kilohms. The instructor could give examples to illustrate this. In the Student Handbook, the student is asked to convert the <math>1k\Omega</math> resistance into ohms.</p> <p>They set up a standard circuit to measure resistance. To begin with, it is a <math>1k\Omega</math> resistor, even though we have a pretty good idea of the answer! The measurement is made at two power supply voltages, in the hope that the results are very similar, as its temperature changes very little.</p> <p>In principle, it is not appropriate to apply Ohm's law to a lamp. Its temperature changes hugely with voltage. In this case, one aim is to show that its resistance does change - increases - with voltage (i.e. temperature.) It is no coincidence that filament bulbs tend to 'blow' when first switched on. Then they are cold and have a low resistance so that the current is at its highest. When the bulb warms up, its resistance increases and the current decreases. The other aim is to estimate its resistance at two power supply voltages in readiness for the next activity.</p>	20 - 30 mins
48 Ohm's law - 2	<p>Students measure the resistance of a combination of two lamps, in series and then in parallel. In series, the lamps each have half of the supply voltage across them, i.e. <math>\sim 6V</math>. The previous activity gave an estimate of resistance under these conditions. The results here should show that their combined resistance in series is around double that value.</p> <p>In parallel, each has the full 12V power supply voltage across it. Again, the previous activity gave an idea of their resistance at 12V. Results here should show a combined resistance in parallel of about half of that value.</p> <p>In domestic installations, the significance of this is that the more devices you connect in parallel, the lower their total effective resistance and so the greater the current demanded from the supply. The rating of cables and fuse values should be appropriate to that demand.</p>	20 - 30 mins

Page	Notes for the Instructor	Timing
49 Measuring resistance - 1	<p>The introduction offers a view of the meaning of electrical resistance but does not define it! It is important that students can manipulate prefixes like 'kilo' and 'milli'.</p> <p>The important aspect of measuring resistance is spelled out at the top of the page - the component under investigation must be disconnected from the circuit first. (Otherwise you might be measuring the resistance of other components in the circuit as well.)</p> <p>As for other measurements using the multimeter, it is important that the range is selected and the probes attached to appropriate sockets before the multimeter is switched on.</p>	10 - 15 mins
50 Measuring resistance - 2	<p>This activity uses the multimeter to measure the resistance of three components, the resistance carrier, the home-made resistor and the 12V bulb.</p> <p>In a way, we are cheating in saying "Choose the 200Ω range..." because in this instance we have a good idea what the resistance is. In general, the rule is - 'Start on the biggest range and work down.'</p> <p>The measurements follow the procedure outlined on the previous page. Measuring the resistance of the 10Ω resistance carrier may seem strange, as the answer looks obvious. However, in part, it reassures the student that they are doing it properly. Also, the measurement will vary a little from the expected. Students should be aware that:</p> <ul style="list-style-type: none"> <li>• components are mass-produced to a tolerance;</li> <li>• meters are not 100% accurate.</li> </ul> <p>Both factors are probably at play here.</p> <p>The purpose of measuring the resistance of the bulb again is to drive home the effect of temperature on resistance. This measurement is made using a tiny current from the multimeter - so small that it causes negligible heating. The student therefore has three measurements of this resistance, at room temperature, at low voltage (6V) and at high temperature. The Student Handbook invites the student to suggest a reason for the differences (= increase of resistance with temperature.)</p>	20 - 30 mins
51 Resistivity -1	<p>The section starts with an important overview of the factors affecting the resistance of a wire. The instructor could draw on the parallel with the flow of water to justify these.</p> <p>Introducing the 'silly' questions aims to bring into focus bulk properties of materials, such as density and resistivity, rather than the properties of particular sample.</p> <p>A detailed discussion of the factors affecting resistance is probably best left until after the next activity, where students make measurements on four different wire samples.</p> <p>The section ends with a suggested 'water equivalent' for resistivity.</p>	10 - 15 mins



Page	Notes for the Instructor	Timing
52 Resistivity -2	<p>The differences between the four Locktronics resistivity carriers is detailed in the table at the beginning of the activity. This information is also printed on the carriers themselves.</p> <p>The students are told to measure the resistance of each, using a multimeter, and record the results in the Student Handbook. They then use these to deduce the effect of length, cross-section and resistivity on the resistance of a sample.</p>	20 - 30 mins
53 Resistivity -3	<p>Here, students measure the resistance of one of the nichrome samples. As previously, the layout identifies the two meters as ammeter and voltmeter but, in reality, both are probably multimeters. The results are used to calculate the resistance of the nichrome sample. (This can be compared with the value obtained in the previous investigation.)</p> <p>The students then go on to calculate the resistivity of nichrome, guided by the example given which refers to a fictitious length of copper wire. The value obtained should be around <math>100 \times 10^{-8} \Omega m</math>.</p> <p>They can then carry out the same process for constantan.</p>	20 - 30 mins
54 Electrical safety	<p>This section starts by reviewing the factors involved in determining the degree of electric shock. The instructor could use a multimeter to measure skin resistance between the hand and the sole of the foot, and between fingers on one hand, both when dry and when wet to illustrate these points.</p> <p>It compares three safety devices, fuse, circuit breaker and RCD, pointing out that only the latter protects the user directly. The first two aim to sense fault conditions and cut off the electricity supply when one occurs. The instructor may need to reinforce this point, as there is a common misbelief that fuses (and circuit breakers) always protect the user.</p> <p>Similarly, it is worthwhile emphasising the advantage of a circuit breaker over a fuse in that a push button resets the former whereas the latter must be replaced with fresh wire or a new cartridge.</p>	5 - 15 mins
55 The fuse	<p>This section discusses the use of fuses. The instructor should emphasise that these are used to protect the wiring and the appliance, but not the user. That is the function of the earth wire. Should any metal casing or metal parts become 'live', the earth wire conducts a very high current, causing the fuse to 'blow'.</p> <p>Fuses appear in a number of formats, depending on where they are used. After an explanation of how they work, the focus is then on plug-top cartridge fuses.</p> <p>The procedure for selecting suitable ratings - use the power formula <math>P = I \times V</math> to calculate the normal appliance current and then choose the next higher fuse value - is outlined and illustrated with an example. Students are then asked to carry out similar calculations for appliances listed in the Student Handbook. The instructor can add further examples to assess the students' understanding.</p>	15 - 25 mins



Page	Notes for the Instructor	Timing
<p>56 The circuit breaker</p>	<p>The section starts with a brief mention of the consumer unit.</p> <p>The instructor may wish to take this opportunity to show one to students, pointing out the MCB and RCD(s). It might be worth mentioning that often there are two RCDs so that only part of a domestic installation is isolated when a fault occurs.</p> <p>Building on the previous section, this looks at the circuit breaker, which has the same function as the fuse, but is re-settable.</p> <p>These work in one of two ways:</p> <ul style="list-style-type: none"> <li>• thermal - a bimetal strip which bends when too hot, releasing a spring-loaded contact, switching off the current;;</li> <li>• electromagnetic - the magnetic field of a solenoid rises to the point where it releases a spring-loaded latch, tripping the supply.</li> </ul> <p>Their current ratings give the minimum current at which they will trip. The three types, B, C and D, differ in the size of current overload needed to cause a rapid (0.1s) trip - 3 times, 5 times and 10 times the current rating respectively.</p> <p>In the circuit, the lamp shows when a current is present. It goes out when the circuit breaker trips. The 'pot' acts to increase the current drawn from the power supply. When this exceeds 1A, the circuit breaker 'trips'.</p> <p>The students are challenged to modify the circuit so that the trip current can be measured. With some groups, it may be prudent for the instructor to check the circuit before it is used.</p> <p>The circuit breaker used on the Locktronics carrier is designed for a minimum of 500 activations. In all likelihood, it will exceed this minimum. Should replacement be necessary, the RS Components stock number for the circuit breaker is (currently) 729-2704.</p>	<p>15 - 25 mins</p>
<p>57 The RCD</p>	<p>The purpose of the RCD is to protect the user of a faulty appliance by shutting off the electricity supply. This distinguishes it from the circuit breaker and fuse. Instructors should ensure that students understand this difference.</p> <p>The introduction outlines the operating principle, of sensing a current imbalance between the line and neutral cables. Instructors might wish to show examples of different types of RCD.</p> <p>Students build a circuit representing a domestic lighting circuit of three lamps, protected by a RCD. As explained above, the RCD compares the current supplied to the lamps with that returning from them. Normally, these are identical and so the RCD does nothing.</p> <p>The circuit allows some of the returning current to bypass the RCD, simulating a fault. This is done by pressing the push switch. At this point, the RCD 'trips' isolating the circuit from the electricity supply.</p> <p>Once again, the challenge is for the student to measure this minimum 'trip' current.</p>	<p>20 - 30 mins</p>

Page	Notes for the Instructor	Timing
58 Earthing	<p>Nearly all electrical installations have a safety earth connection. The details of how this is achieved may differ but the principle is the same - the provision of a low resistance path to ground - so that, when a fault occurs, a large current down this path, causes the fuse to blow, cutting off the electricity supply to the circuit .</p> <p>The diagram illustrates one way to do this - the TN-C-S system. With some students, the instructor may need to point out the important features of the diagram, or illustrate the technique with a mock-up of the components.</p> <p>To end this section on electrical safety, the student is invited to explore a system containing both a circuit breaker and a RCD in order to see the difference in their functions.</p>	15 - 25 mins
59 The energymeter	<p>This section starts by distinguishing between the terms energy and power, terms often confused by students.</p> <p>Energy is a difficult concept to pin down. We know when we've got it, and when we haven't got it. We pay for it on a regular basis - filling the car with petrol, buying a battery, paying a gas bill etc.</p> <p>Power measures how quickly we are going to 'use' energy, (convert it to a different form, to be precise). A powerful car engine probably uses more petrol than a frugal one. A high-power light bulb 'uses' more electricity than a low power one.</p> <p>To add to the confusion, some of the units commonly used sound similar.</p> <p>Officially, energy is measured in joules and power in watts.</p> <p>Often, though, power is rated in kilowatts (kW) and electrical energy in kilowatt-hours (kW-h). (A kilowatt-hour is the energy used in one hour by a device with a power rating of 1kW.)</p> <p>The energymeter is a device designed to allow measurement of energy and power at low voltage. Bearing in mind the formula for electrical power, <math>P = I \times V</math>, it is not surprising that the meter can also display current and voltage readings. With an internal timer, it uses the power reading and elapsed time to calculate energy consumed.</p>	15 - 25 mins
60 Measuring power	<p>This exercise uses the energymeter to measure the power rating of one lamp and then several.</p> <p>The wiring needed is straightforward - the source is connected to the two terminals on the left, allowing the meter to measure source voltage - the load is connected to the terminals on the right because the current must flow through the meter in order to be measured. From those two readings, the power is calculated.</p> <p>The student is challenged to measure the combined power of two lamps, first in parallel and then in series. The instructor can use the results on the Student Handout to assess that the task was carried out correctly.</p>	20 - 30 mins

Page	Notes for the Instructor	Timing
<p>61 Energy and power</p>	<p>The page begins by expanding on the outline given earlier on energy and power.</p> <p>The important part of this page is the power formula. Many students have a blind-spot for formulae and will need this spelling out in fine detail, using words as well as symbols and numbers. Although only two examples are given in this section, many more may be needed before this formula makes sense to some students.</p> <p>‘Smart’ meters are becoming commonplace in domestic and industrial electricity installations. One of their functions is to display the same information as the energymeter, for individual devices or for the full system. This allows the consumer to make informed decisions about electrical energy usage. This could be the basis for an assignment or a piece of individual research by the student.</p>	<p>20 - 30 mins</p>
<p>62 Electro-magnetism - 1</p>	<p>The introduction covers two mapping features which students should be familiar with - contour lines on geographical maps and isobars on weather maps. Neither exist - they are useful in describing the features of a locality or illustrating weather features.</p> <p>Lines of force, or flux lines are equally imaginary but equally useful in depicting the features of a magnetic field. They help our brains to understand something weird - action at a distance. One magnet can move another without touching it - weird!</p> <p>Lines of force show the direction in which a free north magnetic pole would travel. This can never be demonstrated, as free north poles do not exist! However, that’s not going to stop us plotting these lines, using a plotting compass.</p> <p>The north pole on the needle tries to move in one direction while the south pole tries to move in the other. By definition, then, the needle is sitting along a line of force.</p> <p>By moving the plotting compass around the electromagnet, the student obtains a visual impression of the magnetic field pattern created by the electromagnet. They transfer this to a template in the Student Handbook for their records.</p>	<p>20 - 30 mins</p>
<p>63 Electro-magnetism - 2</p>	<p>In this activity, students look for a transient effect using a voltmeter which is designed to ignore transients! Patience is required!</p> <p>The setup will generate several millivolts but as a short-lived pulse. Digital meters sample the input signal and so if the pulse occurs between samples, it will not register a reading. Repeating the process will bring a result eventually! The aim of the activity is limited - just to confirm that a magnet moving through a coil of wire generates electricity.</p> <p>It introduces Fleming’s Right-hand dynamo rule, relating the current direction, the direction of motion and the magnetic field. Students will need plenty of practice in applying this rule.</p>	<p>20 - 30 mins</p>

Page	Notes for the Instructor	Timing
64 Generating electricity - 1	<p>Here, we move from the linear motion in the previous activity to the rotational motion found in alternators. The single coil example needs to be worked through carefully.</p> <p>Students are challenged to apply the dynamo rule to confirm the current direction. Instructors should check that they are able to do this. Giving other orientations of the single coil and other directions of magnetic field and rotation should confirm their understanding.</p> <p>In a second challenge they research the difference between slip-rings and commutators. Cutaway models of motors will help them appreciate how commutators result in a DC output (though not steady DC,) whereas slip-rings result in an AC output.</p>	15 - 25 mins
65 Generating electricity - 2	<p>The focus shifts from a rotating coil inside a magnetic field to a rotating magnetic field inside a coil, usually in the form of an electromagnet.</p> <p>Although this requires electricity, it is only a small current and so the slip-rings used to deliver it last longer. The current for the electromagnet comes from a subsystem called an exciter. Traditionally, a separate DC generator, driven by the same shaft as the main generator, supplied this but now it is derived from the output of the main generator.</p> <p>The diagram shows the construction of a three-phase alternator. Three-phase generation is more efficient than single phase. The Locktronics 'Three-phase systems' module looks at this issue in more detail.</p> <p>The activity goes on to demonstrate how mechanical energy can be converted into electrical energy - the basis of many forms of commercial electricity generation. The first load is a LED. As a form of diode, these allow conduction (and so produce light) only in one direction. Hence, the instructions say that the student should turn the handle gently to begin with, in case the handle is rotated in the wrong direction.</p> <p>The second is a filament lamp. The contrast, in terms of how easy it is to turn the handle, is quite marked, and relates to the efficiency of the two forms of lighting.</p> <p>Note that in the kit are a capacitor and diode for extension activities.</p>	15 - 25 mins
66 Transformers - 1	<p>Transformers work only on AC supplies - a good reason to generate AC!</p> <p>Transformers can appear to be rather magical. The aim in this and the next activity is to show that they are an extension to what we have just studied. If students accept that electricity is generated when a magnet is plunged into a coil, then the transformer is not difficult. The magnet is replaced with an electromagnet, and the motion with a moving magnetic field generated by an alternating current.</p> <p>The focus to begin with is on DC - electricity is generated only when the current is switched on and off. The magnetic field in the electromagnet builds when the current starts to flow and collapses when it stops.</p> <p>As in the earlier activity, sampling may cause a problem if students are using digital multimeters. Continued on the next page...</p>	20 - 30 mins

Page	Notes for the Instructor	Timing
66 Transformers - 1	<p>Continued from previous page ...</p> <p>The voltage generated in the first part of the activity is tiny and easily missed. Instructors may need to check that students are using the correct range on the multimeter (something only a few mV DC). The ferrite rod has a big effect and it's possible to generate around 1V with it in place (though still as a pulse) - a different multimeter range might be needed. It may not be obvious to some students that switching the electromagnet on and off, with DC. causes a moving magnetic field, and hence induces current in the secondary coil. Instructors may need to develop this.</p>	20 - 30 mins
67 Transformers - 2	<p>This is the same activity, but driving the electromagnet with AC.</p> <p>The section starts with a discussion of what caused the 'relative motion' in the previous activity. The work on 'Electromagnetism - 1' should have convinced them that a current is associated with a magnetic field. When the switch is off, there is no current and so no magnetic field. Closing the switch starts a current and the associated magnetic field builds up. (Although we cannot show it with this apparatus, there is a kind of 'chicken and egg' situation here, which brighter students may wonder about. There cannot be a current without a magnetic field and there cannot be a magnetic field without a current. In fact, the current and the magnetic field build up over a short time when the switch is closed.)</p> <p>Students then repeat the same procedure as before with the ferrite rod in place, but using an AC power supply to drive the primary coil. As the current is constantly changing, building and then falling in one direction and then doing the same in the reverse direction, the magnetic field in the primary intensifies, collapses and then reverses. This continuous movement generates a continuous voltage - AC like the driving current. Instructors may need to be wary if the topic of 'step-down' transformers has been mentioned. This is not really 'step-down', just inefficient!</p>	20 - 30 mins
68 Step-down transformer	<p>First, a review of the issues deciding the size of the transformer output voltage, which the instructor could reinforce by discussion and questions. 'Number of turns' is an obvious factor as it determines the performance of both primary and secondary coils. Where there are more turns in the primary than in the secondary, it is known as a 'step-down' transformer. Students will find that the output voltage from the secondary is smaller than applied to the primary.</p> <p>They may be under-whelmed by this. After all, a series resistor would drop the output voltage. However, the results should show that the secondary current is bigger than the primary current. In other words, a 'step-down' transformer steps down voltage but steps up current. A series resistor would waste energy and get hot. The transformer is much more efficient, though not 100% efficient - it will warm up a little. (Hence the need for the cooling systems in substation transformers!)</p> <p>AC current and voltage measurements may require students to move probes between terminals on the multimeter and select AC scales. They may require assistance in doing so.</p>	20 - 30 mins

Page	Notes for the Instructor	Timing
<p>69 Step-up transformer</p>	<p>To begin with, the construction of the ‘step-up’ transformer is discussed. That is followed by discussing applications of step-up and step-down transformers. The students may already have looked at the transmission of electricity over the National Grid. If not, then additional input from the instructor may be appropriate on reducing <math>I^2R</math> heating losses by high voltage transmission. Similarly, for some the idea of rectification may be a new concept and need discussion.</p> <p>The circuit used for the activity has been modified from that used in the previous one. Obviously, the transformer has been reversed. In addition, the 12V lamp has been moved into the primary circuit as a convenient way of reducing the voltage applied to the transformer. As this is a step-up transformer, the secondary voltage will be higher than the primary. More significant though is the question of current. The students will find that the primary current is much larger than the secondary current. Without the reduction in primary voltage, this large primary current could cause overheating in the primary coil of the transformer.</p> <p>The procedure is identical to that for the step-down transformer. The section in the Student Handbook concludes by emphasising that power and hence energy, is not stepped up. In fact the opposite is true, as just pointed out. The transformer will warm up, wasting energy.</p>	<p>20 - 30 mins</p>
<p>70 Transformer relationships</p>	<p>This section reviews the work done on transformers. The concept of flux linkage between the coils may need added support from the instructor.</p> <p>Again ‘number of turns’ is an important factor in determining the performance of the transformer, demonstrated by the transformer relation, given here.</p> <p>The instructor may wish to expand coverage:</p> <ul style="list-style-type: none"> <li>• If it is the ratio that is important, what is the significance of the actual number of turns?</li> <li>• Will a transformer with 10 turns in the primary and 5 in the secondary behave the same as one with 10,000 and 5000 respectively?</li> <li>• The transformer relation applies to an ideal transformer. What is an ideal transformer?</li> </ul> <p>The section ends by stressing once more that practical transformers actually waste energy (but not as much as series resistors!)</p>	<p>15 - 25 mins</p>