

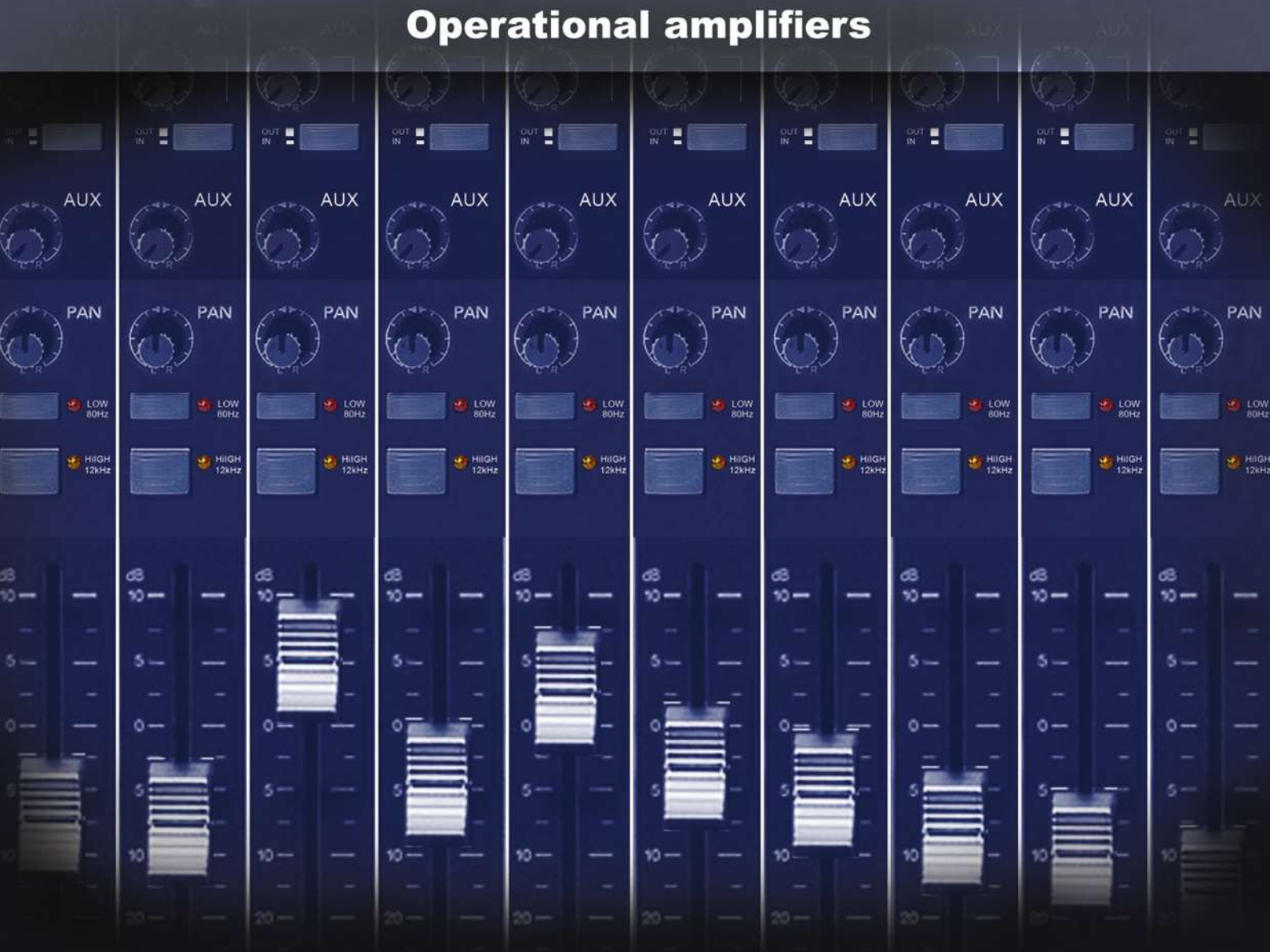

Simplifying Electricity

Operational amplifiers



UPDATED 2023

CP3061

MATRIX www.matrixmultimedia.com

Copyright © 2009 Matrix Multimedia Limited

Contents



Worksheet 1 - Op-amp principles	3
Worksheet 2 - The comparator and Schmitt trigger	5
Worksheet 3 - Non-inverting amplifier	8
Worksheet 4 - Inverting amplifier	10
Worksheet 5 - AC behaviour of amplifiers	11
Worksheet 6 - Voltage follower	14
Worksheet 7 - Summing amplifier	16
Worksheet 8 - Difference amplifier	18
Worksheet 9 - Active treble cut filter	20
Worksheet 10 - Relaxation oscillator	22
Student handout	24
Instructor guide	35
Version control	43

Worksheet 1

Op-amp principles

CP3061-1

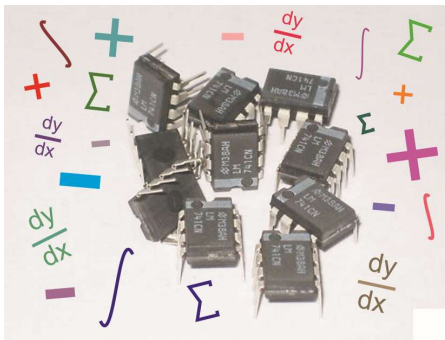

Operational amplifiers (op-amps) are everywhere. They are the most commonly used analogue IC, used in audio systems and instrumentation systems, used to perform mathematical operations, (hence their name,) such as addition, subtraction, and integral and differential calculus.

They were at the heart of analogue computing long before digital computers took over.

Over to you:

- This first investigation explores the circuit shown in the diagram opposite.
- Build this circuit. Use 2 x HP2666 power supplies to generate the +12V positive and -12V negative power supplies.
- Rotate the knob on the potentiometer from one extreme to the other, and notice what happens to the analogue voltmeter reading as you do so.
- Use a digital multimeter (DMM) set on the 20V DC range to measure the voltage V_2 .
- Copy the table shown opposite, and record the value of V_2 in it. Its value will be the same on all rows of the table.
- Use the DMM to monitor the voltage V_1 from the 'pot', and set it to the first value, +9.0V, shown in the table.
- Measure the output voltage V_{OUT} . Record its value in the first row of the table.
- Repeat this process for all other values of V_1 given in the table.
- Now swap over the inputs so that the 'pot', output X, provides input V_2 , and the output Y of the voltage divider made from the two 1kΩ resistors, provides input V_1 .
- Repeat the process outlined above, and compare the performance of the op-amp in the two situations.

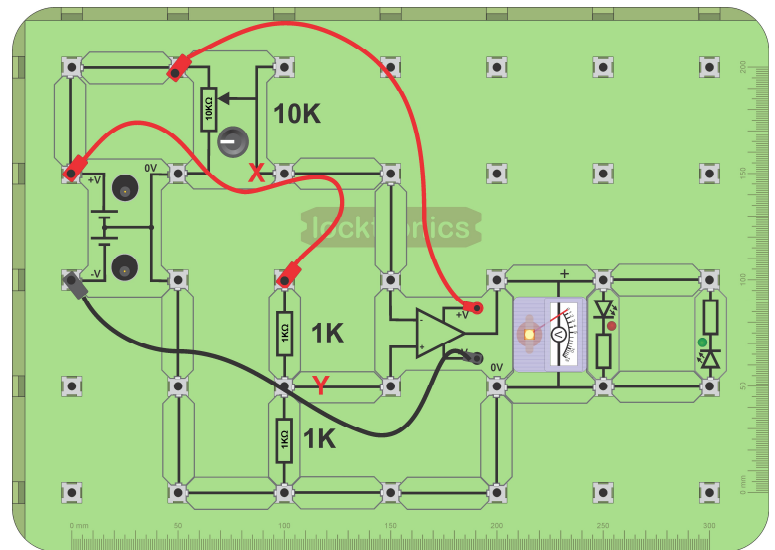
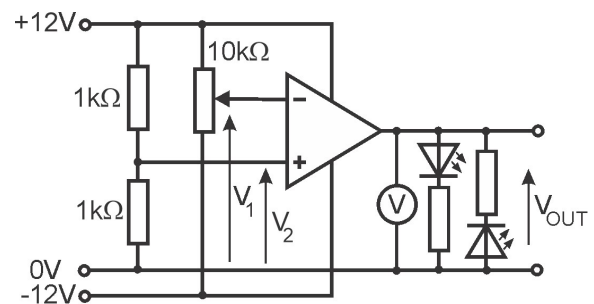

Input voltage V_1	Input voltage V_2	Output voltage V_{OUT}
+9.0V		
+8V		
+7V		
+6V		
+5V		
+4V		

Worksheet 1

Op-amp principles

CP3061-1



So what?

The op-amp has two inputs, **A** and **B**, with a '+' and a '-' sign, and one output terminal **C**.

The circuit symbol is shown below. (The '+' and '-' have nothing to do with the power supply!)

Input **A**, with the '-' sign, is called the **inverting** input.

Input **B**, with the '+' sign, is called the **non-inverting** input.

Op-amps are **high gain differential voltage** amplifiers.

- The voltage **gain** shows how many **times** the output voltage V_{OUT} is bigger than the input V_{IN} : voltage B less voltage A

$$\text{In general: Voltage gain } A = V_{OUT} / V_{IN}$$

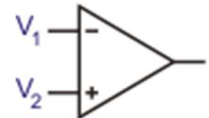

- A **differential voltage** amplifier amplifies the **difference** in the input voltages.
- For example, when a voltage, V_2 , of $10\mu\text{V}$ is applied to input B and a voltage, V_1 , of $7\mu\text{V}$ to input A, then the amplifier would amplify the **difference**, $3\mu\text{V}$.

The basic equation for the op-amp is:

$$V_{OUT} = A \times (V_2 - V_1)$$

A_0 is called the **open-loop voltage gain**, as there is no 'loop' between output and input.

Op-amps have a **high gain**, with A typically $\sim 100,000$, so that the output voltage is typically 100,000 times bigger than the input voltage **difference**. When the difference is $3\mu\text{V}$, the output voltage is $300,000\mu\text{V}$ ($= 0.3\text{V}$.)

Op-amps can't solve the energy crisis. We can't apply a voltage difference of 1V at the inputs and hope to get 100,000V at the output. The equation is true only when the output voltage is between the power supply voltages - in this case around +13V and -13V. When V_{OUT} reaches these limits, we say that it is **saturated**. In worksheet 1, the output is always saturated.

When V_2 is bigger than V_1 , the output is as close as it can get to the positive supply voltage, a value known as the positive saturation voltage. When V_1 is bigger than V_2 , the output is close to the negative supply voltage, and is known as the negative saturation voltage.

This circuit is called a **comparator**. It compares the input voltages and shows which is bigger. When V_2 is bigger than V_1 , (i.e. the '+' input voltage is bigger,) V_{OUT} is in **positive** saturation. When V_1 is bigger than V_2 , (i.e. the '-' input voltage is bigger,) V_{OUT} is in **negative** saturation.

For your records:

- Copy the circuit symbol for the op-amp and add labels to identify the three terminals.
- Copy the formula for voltage gain, and the basic equation for the op-amp .
- Explain what is meant by:
 - high gain differential voltage amplifier
 - saturation
 - comparator.

Worksheet 2

The comparator and Schmitt trigger

CP3061-2



Control systems of all kinds rely on sensors to tell them what is happening. Many of these offer simple digital outputs - either 'on' or 'off'. Some sensors are analogue devices, where, for example, the output of the sensor changes with temperature, .

The op-amp comparator circuit converts these analogue signals to digital. In some cases, we need to avoid 'chatter' where the digital output keeps switching from one value to the other rapidly. One solution is to use a Schmitt trigger circuit.

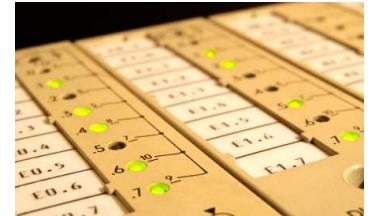

Over to you:

1. The comparator:

- Set up the circuit shown. The layout shows one way to do this. Adjust the 'pot'. The LED will light at some point. Turn the 'pot' back until the LED is only just lit.
- Now warm up the thermistor with your fingers. The LED should go out. Let it cool down again. When it gets cold enough, the LED will light to warn that the temperature has fallen.
- You should find that there is a well-defined 'turn-on' point, controlled by the signal from the 'pot'. The LED is either on or off - the output is digital. There is only one threshold - the LED switches on and off at virtually the same voltage.

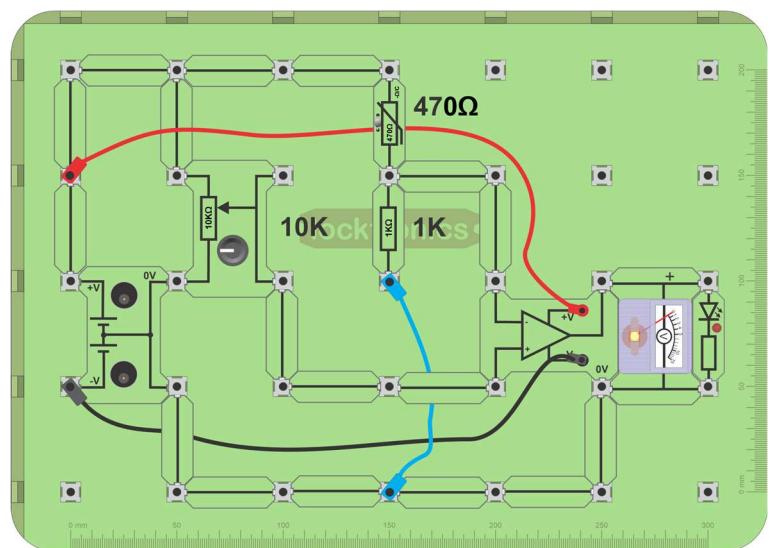
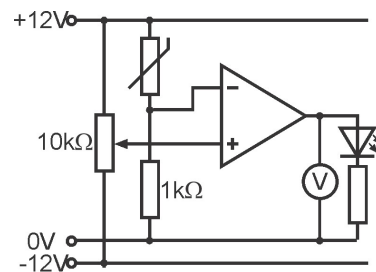

So what?

The comparator is the easier circuit to design and use.

- The LED switches on and off at the same threshold voltage, V_2 , set by the 'pot'.
- The temperature-sensing unit consists of a thermistor and a fixed resistor.
- As the temperature falls, the thermistor resistance rises, and so the output voltage, V_{OUT} , falls.
- When V_1 falls below the value of V_2 , the LED switches on.

Worksheet 2

The comparator and Schmitt trigger

CP3061-2

Near the switching threshold, any electrical noise could push the signal over the threshold, and cause the output to switch rapidly on and off, from the noise alone. If this is the case, it may be better to use a Schmitt trigger circuit.

The behaviour of the op-amp is unchanged:

- When V_2 is bigger than V_1 , the LED is on.
- When V_1 is bigger than V_2 , the LED is off.
- The output of the op-amp sits at either $+V_{sat}$ (positive saturation,) or $-V_{sat}$ (negative saturation.)
- The two equal ($1k\Omega$) resistors are connected in series between the output and 0V and so each has a voltage drop of $\frac{1}{2}V_{sat}$ across it. Hence $V_2 = \frac{1}{2}V_{sat}$.
- For example, ideally the output of the op-amp should saturate at around $+12V$ and $-12V$. This means that V_2 is either $+6V$ or $-6V$.
 - When the LED is off, the op-amp output is $-12V$, and $V_2 = -6V$. The input signal, V_1 must fall below $-6V$ to switch the LED on.
 - When the LED is on, the output of the op-amp is $+12V$, and $V_2 = +6V$. The input signal, V_1 must rise above $+6V$ to switch the LED off.
 - There are now **two** switching thresholds.

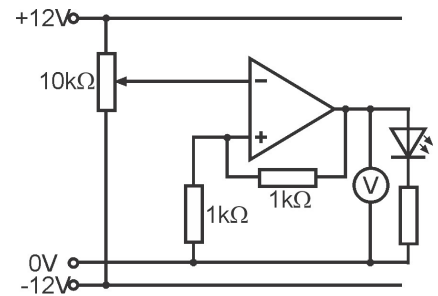

Schmitt trigger

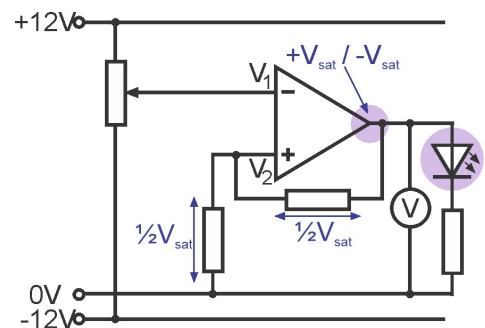

Over to you:

2. The Schmitt trigger:

The comparator has only one threshold. If the signal from the sensor sits very close to that threshold and wobbles up and down a little, then the LED can flash on and off unnecessarily. The next circuit avoids that.

- Set up the circuit shown.
- To simplify the investigation, the temperature-sensing unit has been replaced by a 'pot'.
- The 'pot' now acts as the sensor. Turn it until the LED lights. Now turn the 'pot' back until the LED turns off.

So what?

- You should find that there are now two thresholds. The LED turns on at one voltage, and off at another.
- This resolves the issue about unnecessary switching.

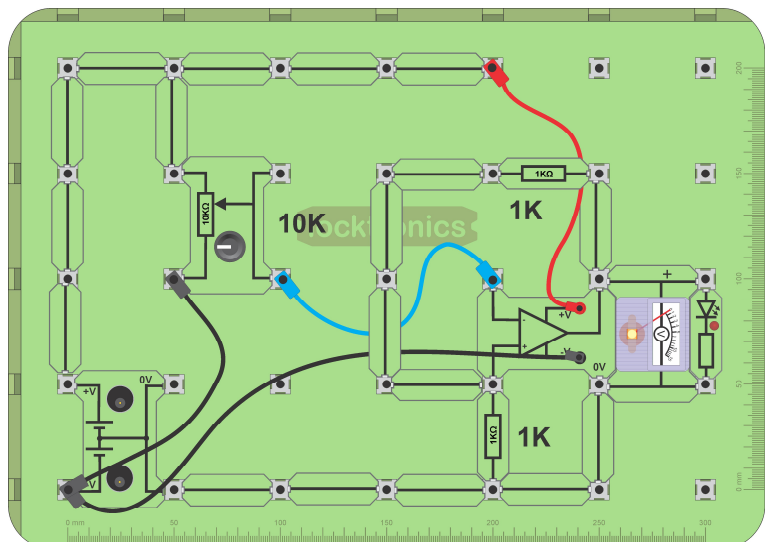

Worksheet 2

The comparator and Schmitt trigger

CP3061-2



For your records:

- Draw the circuit diagram to show a temperature-sensing unit connected to :
 - a comparator circuit;
 - a Schmitt trigger circuit.
- Write a clear explanation in no more than 50 words on the difference between comparators and Schmitt triggers.
- Design a Schmitt trigger circuit like the one above but which has switching thresholds of +2V and -2V. Assume that the saturation voltages are +12V and -12V.

Worksheet 3

Non-inverting amplifier

CP3061-3



Audio systems need careful design. It's not enough to design each stage as a separate system. Each stage must 'talk' effectively to the next, i.e. must transfer its signal without loss or distortion.

The op-amp has a number of roles in this. Designed properly, the non-inverting amplifier draws very little current from the input subsystem that supplies it with an audio signal, an important element of the design.

Over to you:

- The next investigation uses the circuit shown opposite.
- Build this, using a value of $1k\Omega$ for R_F and $1k\Omega$ for R_1 . One way to do so is shown in the picture below.
- Use a digital multimeter (DMM) set on the 20V DC range to monitor the voltage V_{IN} . Turn the 'pot' to set this voltage to +2.5V.
- Copy the table shown opposite.
- Measure the output voltage V_{OUT} and record its value in the first row of the table.
- Repeat this process for all the other values of V_{IN} .
- Calculate the gain using the formula:
Voltage gain = V_{OUT} / V_{IN}
- Use your results to complete the third column.
- Now swap the $1k\Omega$ feedback resistor for a $10k\Omega$ resistor.
- Make a copy of the second table.
- Repeat the process outlined above, using the new values of V_{IN} given in the second table.
- Complete the second table in the same way as before.

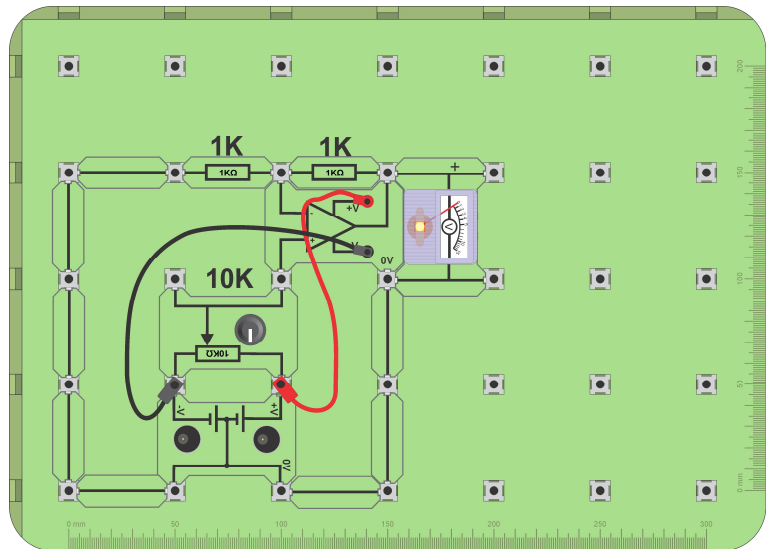
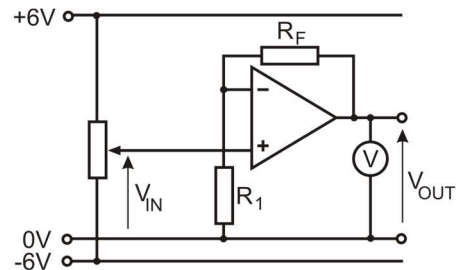

$R_F = 1k\Omega, R_1 = 1k\Omega$		
V_{IN}	V_{OUT}	Gain
+2.5V		
+1.5V		
+0.5V		
-0.5V		
-1.5V		
-2.5V		

$R_F = 10k\Omega, R_1 = 1k\Omega$		
V_{IN}	V_{OUT}	Gain
+0.5V		
+0.3V		
+0.1V		
-0.1V		
-0.3V		
-0.5V		

Worksheet 3

Non-inverting amplifier

CP3061-3



So what?

The industry standard op-amp is the '741', produced by Fairchild Semiconductors in 1968. Since then, many improvements have been made to the performance.

The ideal characteristics of an op-amp are:

- infinite open-loop voltage gain;
- infinite bandwidth, (the range of frequencies amplified successfully;)
- infinite input impedance, (draws no current from the device creating its input signal;)
- infinite slew-rate, (the output voltage can leap instantly to any value;)
- zero output impedance, (delivers the full output voltage to any subsystem that follows;)
- infinite common-mode rejection ratio (CMRR) (amplifies only the difference in voltage between the inputs and ignores any voltage common to both, such as interference.)

Often, subsystems delivering a signal to an amplifier, such as a microphone, cannot provide much current. If the amplifier draws significant current from it, then the signal voltage falls, defeating the point of using an amplifier. The non-inverting amplifier, however, offers a very high input impedance, typically $1M\Omega$, so that it draws very little current from its signal source.

The theoretical value for the voltage gain is given by the formula:

$$\text{Voltage gain} = 1 + R_F / R_1$$

For the first part of the investigation, where $R_F = 1k\Omega$ and $R_1 = 1k\Omega$, this gives a value:

$$\text{Voltage gain} = 1 + 1 / 1 = 2$$

(Using any two equal valued resistors would give the same voltage gain. Using high values reduces battery drain and power dissipation.)

For the second part, where $R_F = 10k\Omega$ and $R_1 = 1k\Omega$, this gives a value:

$$\text{Voltage gain} = 1 + 10 / 1 = 11.$$

Look at your measurements. Do they support these values of voltage gain?

For your records:

- Draw the circuit diagram for the non-inverting voltage amplifier.
- Write down the formula linking voltage gain to input voltage and output voltage.
- Write down the formula linking the voltage gain of a non-inverting amplifier to the values of the feedback resistor and resistor R_1 .
- Copy the following table and complete it:

Input voltage	Output voltage	Voltage gain	Resistor R_F	Resistor R_1
5mV			22k Ω	2k Ω
	300mV	15		1k Ω
20mV	400mV		38k Ω	
10mV		10		10k Ω
3mV	18mV		100k Ω	

Worksheet 4

The inverting amplifier

CP3061-4



The inverting amplifier is somewhat inferior as a voltage amplifier, but it leads to a number of exciting applications that are based on this circuit.

The fact that it inverts the signal is rarely significant - an audio signal sounds just the same whether or not it is inverted! More important - the inverting amplifier usually draws more current from its signal source, than does the non-inverting amplifier, and so needs careful design.

Over to you:

- The next investigation uses the circuit shown opposite.
- Build this, using a value of $10\text{k}\Omega$ for R_F and $10\text{k}\Omega$ for R_{IN} .
- Use a multimeter to monitor the input voltage V_{IN} . Turn the 'pot' to set this to $+2.5\text{V}$.
- Copy the first table.
- Measure the output voltage V_{OUT} and record it in the first row of the table.
- Repeat this process for all the other values of V_{IN} .
- Calculate the voltage gain using the formula: $\text{Voltage gain} = V_{OUT} / V_{IN}$ and hence complete the third column.
- Now swap the $10\text{k}\Omega$ input resistor for a $1\text{k}\Omega$ resistor.
- Make a copy of the second table.
- Repeat the same process, using the values of V_{IN} given in the second table.
- The formula for calculating the voltage gain is $\text{Gain} = - R_F/R_{IN}$ instead of $\text{Gain} = 1 + R_F/R_{IN}$ for the non-inverting amplifier.
- How could you use a $10\text{k}\Omega$ resistor and two $1\text{k}\Omega$ resistors to give you a voltage gain of 5?
- Test your idea by modifying the circuit you used above.

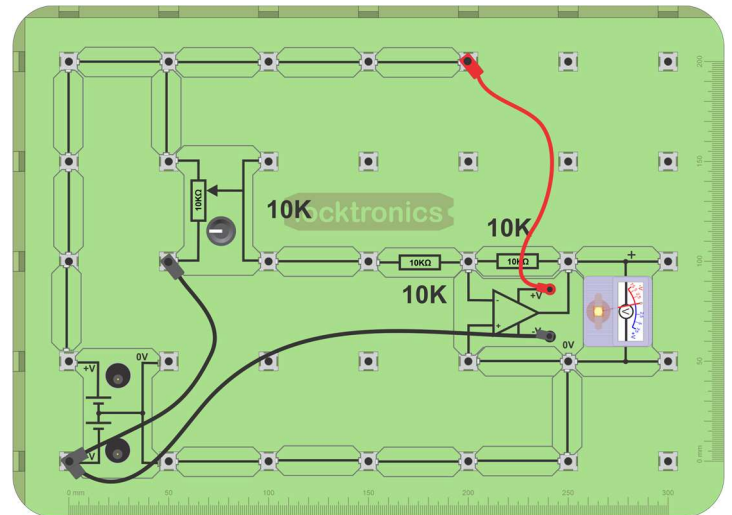
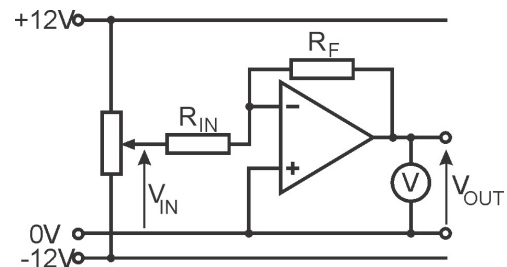

$R_F = 10\text{k}\Omega, R_{IN} = 10\text{k}\Omega$		
V_{IN}	V_{OUT}	Gain
+2.5V		
+1.5V		
+0.5V		
-0.5V		
-1.5V		
-2.5V		

$R_F = 10\text{k}\Omega, R_{IN} = 1\text{k}\Omega$		
V_{IN}	V_{OUT}	Gain
+0.5V		
+0.3V		
+0.1V		
-0.1V		
-0.3V		
-0.5V		

Worksheet 4

The inverting amplifier

CP3061-4



So what?

An important observation:

$$V_2 = V_1$$

in any op-amp circuit where the output is not saturated,

The reason:

- The output voltage is never very large, say 10V maximum.
- Provided that the output is not saturated,

$$V_{OUT} = A_0 \times (V_2 - V_1).$$

- Open loop gain, A_0 , is around 100,000.
- Hence, $10 = 100,000 \times (V_2 - V_1)$, so $(V_2 - V_1) \sim 0.0001V$, or, to a good approximation:

$$V_2 = V_1$$

In the case of the inverting amplifier, $V_2 = 0V$, because it is connected directly to it.

As long as the output is not saturated, $V_1 = 0V$ also. This can be a good experimental check that the op-amp is working correctly.

For the inverting amplifier:

$$\text{Voltage gain} = - R_F / R_{IN}$$

As a result:

- when $R_F = R_{IN}$, the voltage gain = -1;
- when $R_F = 10 \times R_{IN}$, the voltage gain = -10, and so on.

However, because $V_1 = 0V$ when the output is not saturated, (and amplifiers should never be driven into saturation,) the input source sees the amplifier as having a resistance of R_{IN} : The value of R_{IN} should be kept large in order to limit the current that the amplifier draws from the input source. It should be at least $1k\Omega$, and preferably bigger than $10k\Omega$.

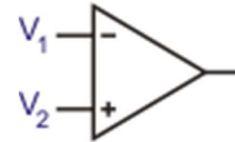

For your records:

- Draw the circuit diagram for the inverting voltage amplifier.
- Write down the formula linking the voltage gain of an inverting amplifier to the values of the feedback resistor and input resistor.
- Copy the following table and complete it:

Input voltage	Output voltage	Voltage gain	Resistor R_F	Resistor R_{IN}
5mV			20k Ω	2k Ω
	-300mV	12		10k Ω
20mV	100mV		100k Ω	
-10mV		3		10k Ω
3mV	-24mV		240k Ω	

Worksheet 5

AC behaviour of amplifiers

CP3061-5



Earlier investigations into the behaviour of inverting and non-inverting amplifiers used DC input signals. That is fine for outline investigations. But in many instances amplifiers are used with AC signals: for example with audio.

This investigation checks that the behaviour is identical when we replace the DC signals (i.e. 0Hz) with audio frequency signals.

Over to you:

1. Non-inverting amplifier

- Build the circuit shown
- Copy the table.
- Set the signal generator to give a signal with a frequency of 100Hz and amplitude 0.3V. Inject the signal at point A.
- Use an oscilloscope to measure the amplitude of the output signal at B. Record it in the table for various frequencies.
- Calculate the gain for each value of frequency.
- Experiment with other values of R_F and R_1 .

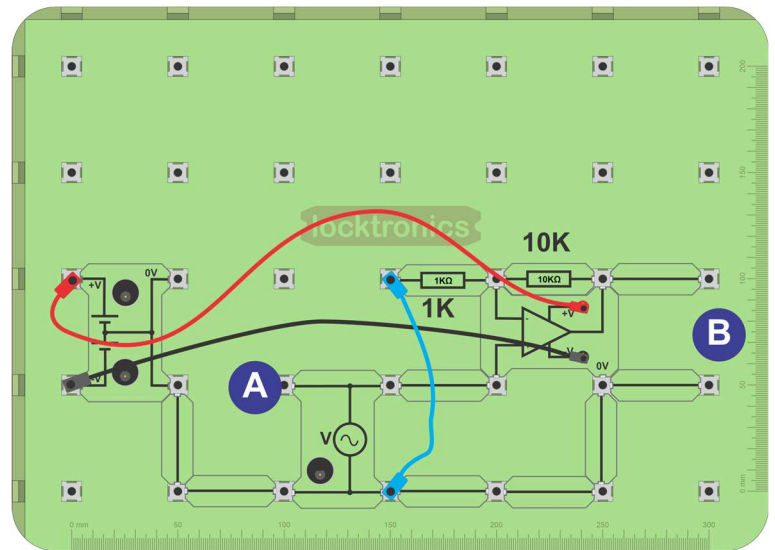

$R_F = 10k\Omega$ $R_1 = 1k\Omega$

Frequency	V_{IN}	V_{OUT}	Gain
100	0.3V		
500	0.3V		
1000	0.3V		
5000	0.3V		

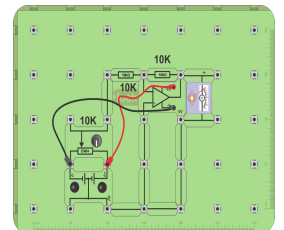

2. Inverting amplifier

- Convert your circuit into an inverting amplifier, with $R_F = 10k\Omega$ and $R_{IN} = 1k\Omega$. The picture shows one way to do this.
- Make a second copy of the table.
- Input the signals given in the table, and measure the amplitude of the output each time.
- Record your results in the table.
- Calculate the gain for each value of frequency and experiment with other values of R_F and R_{IN} .

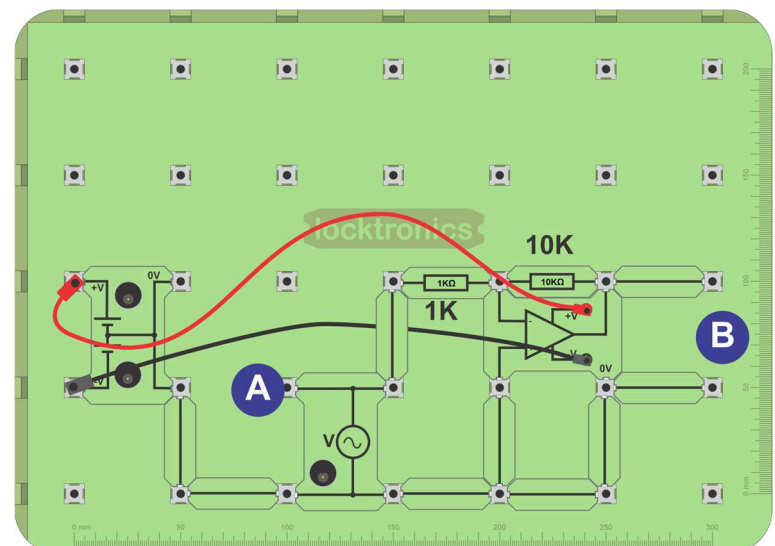
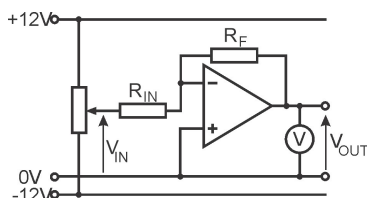

Worksheet 5

AC behaviour of amplifiers

CP3061-5



So what?

- First result - the same rules apply for AC as for DC. The voltage gains are governed by the same formulae.
- What is not quite as obvious is that the inverting amplifier inverts the signal. When the input voltage is positive and increasing, the output is negative and decreasing, and so on. The non-inverting amplifier does not invert the signal.
- The reasons that these are not necessarily obvious are:
 - audio signals sound the same 'both ways up.'
 - The oscilloscope traces start on a rising voltage if you use the settings given above.

Try this:

Increase the amplitude of the input signal while watching the output using Picoscope. At some point, the beautiful sine waves distort, becoming flattened at the top and bottom. This is where the output is becoming saturated. The effect is called clipping distortion. Add a speaker and listen to the effect on the sound produced by the loudspeaker. (Note you will get some distortion as the op amp output is not designed for driving a speaker).

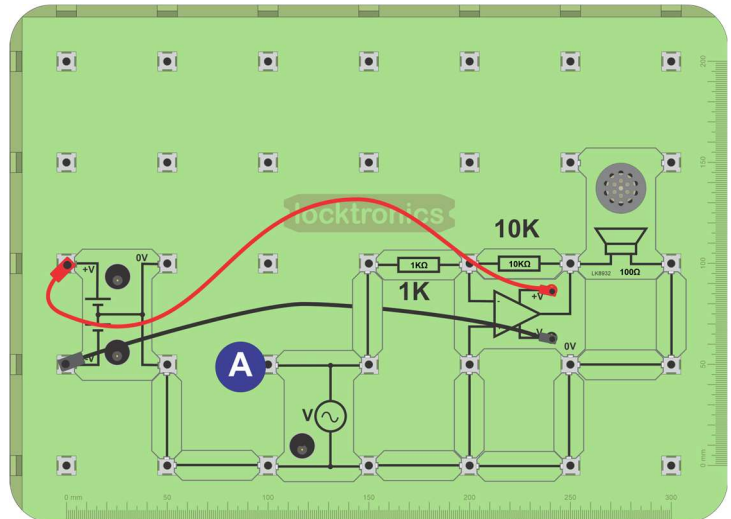

For your records:

- Explain to an intelligent friend, who has not done this investigation, what causes clipping distortion.
- Draw a voltage / time graph to show the effect of clipping distortion on a sine wave signal.

Worksheet 6

Voltage follower

CP3061-6

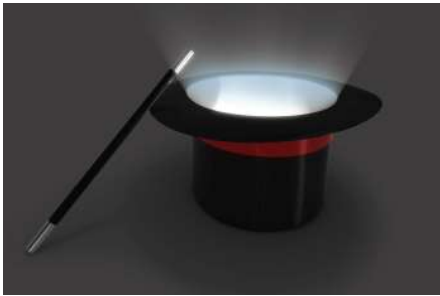

What you're about to investigate may seem like magic!

The voltage follower, or buffer, behaves like a simple length of wire, in voltage terms, but with an important difference - it draws very little current from the signal source.

It is an extreme form of a non-inverting amplifier, using zero ohms as the feedback resistor, and infinite ohms as resistor R_1 .

Over to you:

1. Behaves like a length of wire:

- Set up the first circuit.
- Notice the connecting link between output and inverting input, (see the ! symbol.) This provides the 100% feedback.
- Copy the table shown below.
- Use a digital multimeter (DMM) to monitor the voltage V_{IN} . Turn the 'pot' to set this voltage to +2.5V.
- Measure the output voltage V_{OUT} and record it in the table.
- Repeat this process for all the other values of V_{IN} .

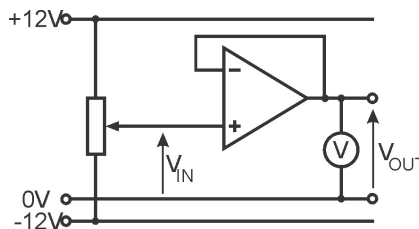

V_{IN}	V_{OUT}
+2.5V	
+1.5V	
+0.5V	
-0.5V	
-1.5V	
-2.5V	

2. The magic bit:

What we want to do now is use a thermistor to control the speed of a fan. Set up the second circuit (no op amp).

- When you test this, you will find that it does not work. Disconnect the motor. The voltmeter shows a healthy reading, which rises when the temperature increases. Re-connect the motor and this reading falls to nearly zero.
- Now set up the third circuit, using a potentiometer to mimic the thermistor function, and test it. The motor affects the output voltage, but nowhere near as much, and you should be able to control the speed of the motor with the potentiometer. This version of the circuit works well.

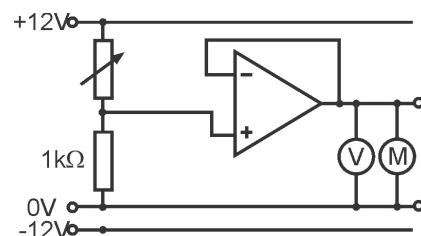
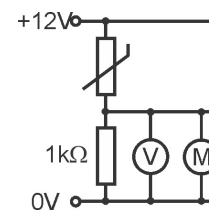
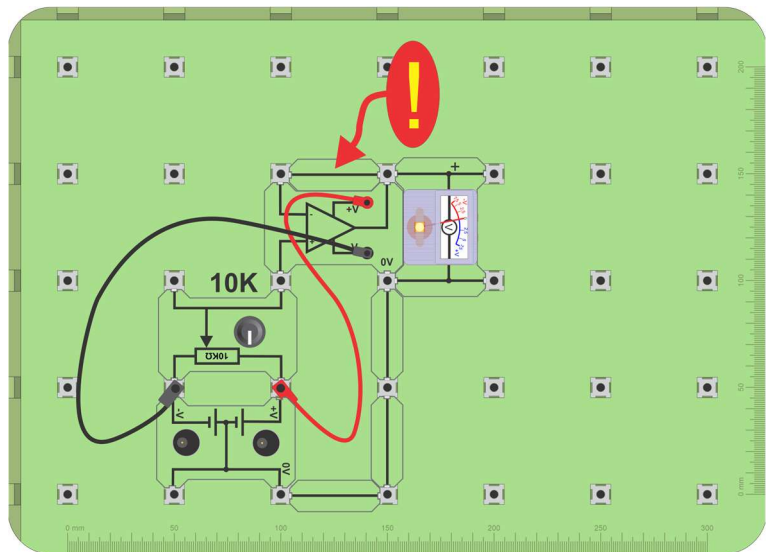

Worksheet 6

Voltage follower

CP3061-6

So what?

Matching for voltage transfer:

No matter how complex its inner workings, we can picture an electronic subsystem as a voltage source, V_S , in series with an output resistance, R_O .

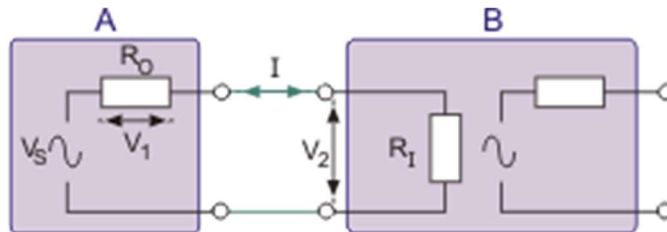

The diagram shows two subsystems, **A** and **B**. Our design aim is to pass on as much of the voltage V_S as possible. In other words, we want V_2 , the voltage 'seen' by **B**, to be as close as possible to V_S , the voltage generated by **A**.

Now $V_2 + V_1 = V_S$, so we want to make V_1 as small as possible, by making the current I as small as possible. In turn, this means that the input resistance of **B**, R_I , must be much bigger than R_O , the output resistance of **A**.

The non-inverting amplifier has an input resistance of at least 1 M Ω . (Different op-amps have different input impedances. The TL081 used in the Locktronics op-amp carrier has an input resistance of $10^{12} \Omega$ and an output resistance of around 200 Ω .) As a result, the current drawn from the input signal source is very small, and the loss of signal (V_1 in the diagram,) is small.

As a result, when connected to the temperature sensing unit, in part 2 of the investigation, the voltage follower has very little effect on the output of the sensor. The voltage from the sensing unit is conveyed with little change to the output of the follower. The motor now draws current from the op-amp, and not from the sensing unit.

For your records:

- Draw the circuit diagram for the op-amp voltage follower.
- Copy and complete the following:
 - In a voltage follower, the output voltage is to the input voltage. However, the input impedance (resistance) of the voltage follower is so big that it draws current from the input signal source. As a result, it has little or no effect on the input signal. The output device draws current from the op-amp and not from the signal source.
- Use the internet to research the following terms and explain each in less than 25 words:
 - buffer;
 - 100% feedback;
 - equivalent circuit.

Worksheet 7

The summing amplifier

CP3061-7



The inverting amplifier has only one input. However, we can add other inputs in such a way that each operates independently. We can then incorporate variable resistors that allow us to fade in and fade out input signals.

We call the result a summing amplifier, and it is widely used in audio recording and broadcasting as the mixing desk.

Over to you:

1. Summing

- Build this, using $10\text{k}\Omega$ resistors for R_F , R_1 and R_2 . The picture shows one way to do this.
- Use a DMM to monitor the input voltages V_1 and V_2 . Set their values to those given in the first line of the table.
- Copy the table.
- Measure the output voltage V_{OUT} and record it in the first row of the table.
- Repeat this process for all the other values of input voltages.
- Now swap the $10\text{k}\Omega$ feedback resistor for a $1\text{k}\Omega$ resistor. Use the same process as before to investigate this circuit.
- Record your results in a new table, similar to that used above.

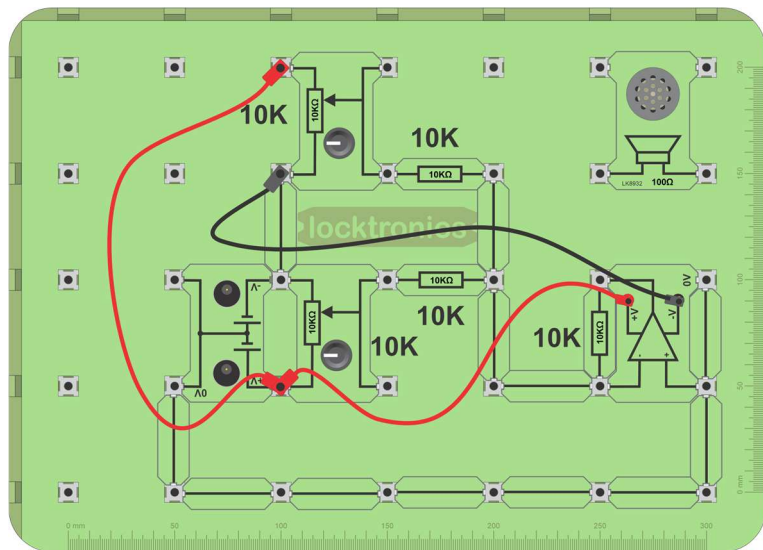
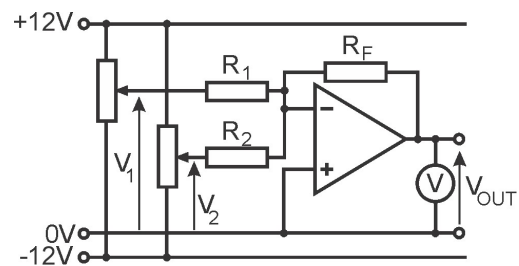

2. Mixing

- Modify the circuit as shown in the circuit diagram below by adding variable resistors to the inputs.
- Connect audio signal sources, such as a Mobile phone and a signal generator, to inputs A and B.
- Notice the effect of changing the variable resistor settings on the output
- You can add a loudspeaker but note that the impedance match is wrong so the sound quality is not good.

$R_F = R_2 = R_1 = 10\text{k}\Omega$		
V_2	V_1	V_{OUT}
+2.0V	+1.0V	
+1.5V	+1.0V	
+0.5V	-0.5V	
-0.5V	-0.5V	
-1.5V	+2.0V	
-2.5V	+2.0V	

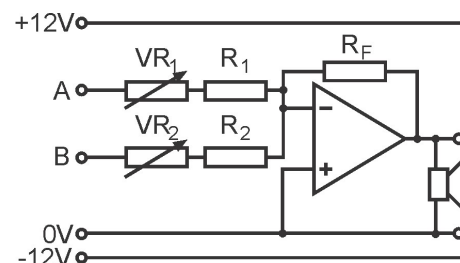

Worksheet 7

The summing amplifier

CP3061-7

So what?

The circuit diagram for the summing amplifier is repeated opposite with some of the relevant values added.

Here's the analysis of this circuit when input $V_2 = +2.0V$, and input $V_1 = +1.0V$:

- It's an amplifier, so the output should not be saturated.
- Hence, the two inputs will sit at the same voltage.
- The non-inverting input is connected to 0V, so the inverting input sits at 0V.
- For each input, the full input voltage is dropped across the input $10k\Omega$ resistor.
- Using Ohm's law, the current flowing through the upper $10k\Omega$ input resistor is **0.1mA**, and the current flowing through the lower $10k\Omega$ input resistor is **0.2mA**.
- We assume that the op-amp is ideal, and so no current flows into the op-amp through its inverting input. As a result, the input currents combine, to give **0.3mA**, which flows through the feedback resistor into the output circuit.
- Applying Ohm's law to the feedback resistor, the voltage across it is $0.3 \times 10 = 3V$.
- The left-hand end of the feedback resistor sits at 0V.
- The current flows from there to the output, so that must be more negative, (as current flows from positive to negative voltages.)
- This means that the output voltage is 3V lower than 0V. In other words, $V_{OUT} = -3V$.
- This circuit is a summing amplifier indeed! It added together the input voltages (and inverted the result.)

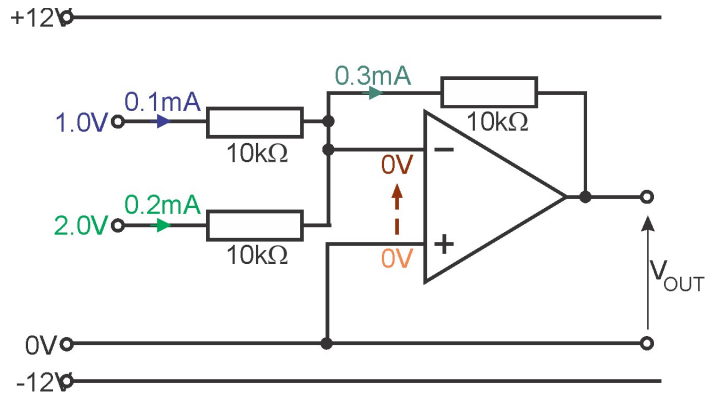

Note: if using your mobile phone to generate audio then you may need to change resistor values.

For your records:

- Copy the circuit diagram for the summing amplifier, given on the previous page.
- Copy out the steps of the analysis given above, but modify them by using the values given in the last line of the results table, where $V_2 = -2.5V$ and $V_1 = +2.0V$.
(The current will flow the opposite way in input V_2 , because the voltage is negative!)

Worksheet 8

The difference amplifier

CP3061-8

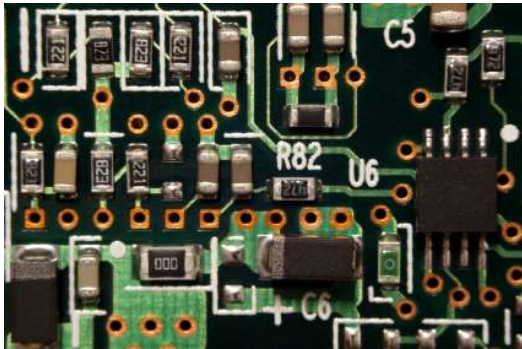

The difference amplifier finds its applications in instrumentation systems. Its name gives a clue as to what it does. The importance to instrumentation lies in its ability to distinguish between background components to a signal, such as temperature and power supply voltage, and the true signal. It is often used in conjunction with bridge circuits. For example, monitoring strain in civil engineering, such as bridges and high-rise buildings.

Over to you:

- The next circuit is another modification of the inverting amplifier used in worksheet 5. It is shown opposite.
- Build this, using two 10kΩ resistors and two 1kΩ resistors. Notice the symmetry of the arrangement.
- The picture shows one way to build this.
- Use a DMM to monitor the input voltages V_A and V_B . Set their values to those given in the first line of the table.
- Copy the table.
- Measure the output voltage V_{OUT} and record it in the first row of the table.
- Repeat this process for all the other values of input voltages. As with all amplifier circuits, it is important to avoid output saturation.
- Analyse your results. Can you see the pattern that links V_{OUT} to V_A and V_B ? Test your theories by trying other combinations of input voltages, and predicting the result.

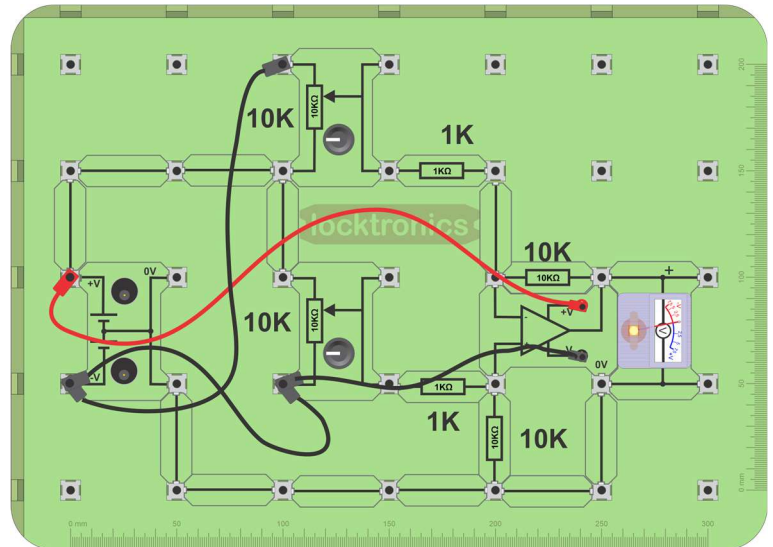
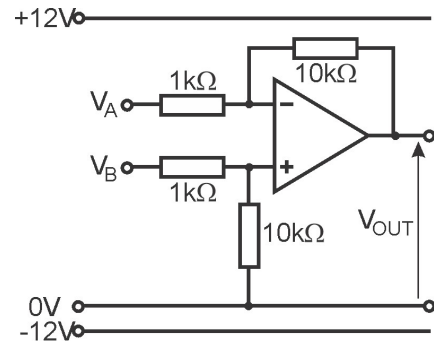

V_B	V_A	V_{OUT}
+2.0V	+1.8V	
+1.5V	+1.2V	
+0.4V	0V	
0V	-0.2V	
-1.5V	-1.3V	
-2.2V	-2.6V	

Worksheet 8

The difference amplifier

CP3061-8

So what?

Here is an analysis of the performance of the difference amplifier.

(The values of the resistors have been changed to make the arithmetic easier.)

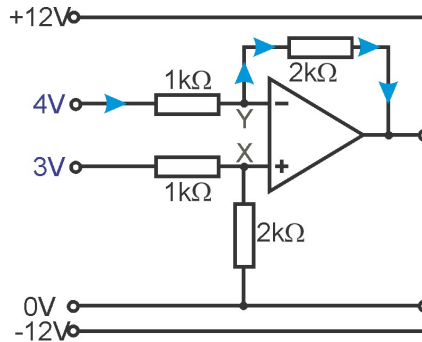

Earlier we pointed out that the ideal op-amp has infinite input impedance, and so draws no current from its input source. We will assume that this op-amp is ideal!

Look at point X, the non-inverting input of the op-amp. It is at the centre of a voltage divider. We can draw it as shown opposite:

There is a 3V drop across two resistors, one of which is twice as big as the other. As a result, the 2kΩ resistor takes twice as much of the voltage as does the 1kΩ resistor, giving 2V across the 2kΩ resistor and 1V across the 1kΩ resistor. In other words, point X sits at 2V.



Assuming that the output of the op-amp is not saturated, the two inputs must sit at the same voltage and so point Y sits at 2V also.

The output of the op-amp can be viewed as part of a voltage divider. The 1kΩ input resistor has a 2V drop across it (from 4V at the input to 2V at point Y.) The 2kΩ resistor in series with it must have twice as big a voltage drop, i.e. 4V.

Looking at the blue current arrows on the diagram, current flows from point Y to the output. That means that the output is at a lower voltage than point Y, in this case 4V lower. As Y is at 2V, the output must be at $(2 - 4) = -2V$.



For your records:

- Draw the circuit diagram for the difference amplifier.
- Calculate the output voltage if all four resistors in the circuit have a resistance of 10kΩ, and the input voltages are:

$$V_A = +6V$$

$$V_B = +4V$$

Explain carefully how you obtain your answer.

Worksheet 9

Active treble cut filter

CP3061-9



The acoustic range for human hearing is taken to be the frequency range 20Hz to 20kHz. An ideal amplifier offers the same voltage gain to all these frequencies. However, there are situations where we want to boost or cut certain frequency ranges. For example, we might feel that a particular audio signal sounds ‘tinny’ or too shrill. In that case we can employ a circuit that cuts the treble frequencies in that signal. In hi-fi systems, these are usually called tone controls.

Over to you:

- Another modification of the inverting amplifier is shown opposite.
- Build this, using the picture as a guide if you wish.
- The input signal is provided by a signal generator.
- The output is monitored on an oscilloscope. Suitable settings are given at the bottom of the page.
- Set the signal generator to give a sine-wave signal with a frequency of 50Hz and a peak amplitude of 0.2V, and connect it at point A (V_{IN}).
- Copy the table, and write in the actual value of signal amplitude.
- Measure the amplitude of the output on the oscilloscope and record it in the first row of the table.
- Repeat this process for the other frequencies given in the table with the same input signal amplitude. Measure and record the amplitude of the output signal in each case.
- Complete the third column of the table for your results.

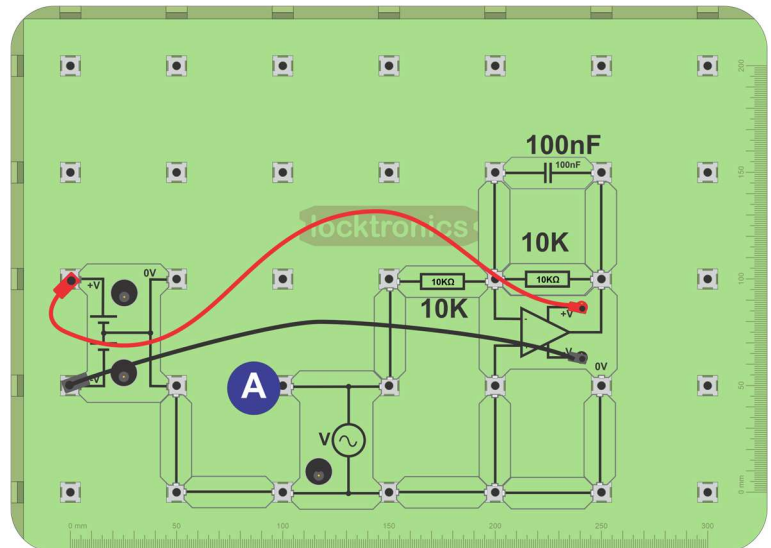
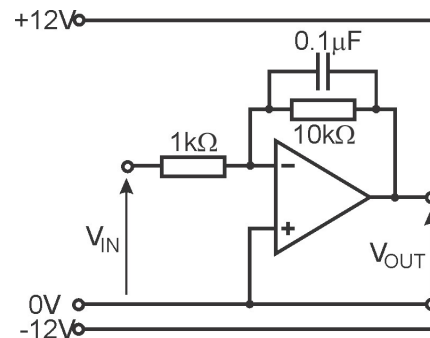

Frequency	V_{IN}	V_{OUT}	Gain
50Hz			
100Hz			
150Hz			
200Hz			
250Hz			
300Hz			
400Hz			
500Hz			

Worksheet 9

Active treble cut filter

CP3061-9



So what?

- The circuit behaves like a 'normal' inverting amplifier, except that feedback is supplied via the resistor - capacitor combination.
- Capacitors behave like very large resistors at low frequencies, and as smaller and smaller resistors as the frequency rises.
- At a very low frequency, the capacitor behaves exactly like its circuit symbol - as a break in the circuit. At this stage, no current flows through the capacitor. Feedback is via the 10kΩ resistor only, and so the voltage gain is $R_F / R_{IN} = 10\text{k}\Omega / 1\text{k}\Omega = 10$.
- At a very high frequency, the capacitor behaves like a short-circuit across the feedback resistor. No current flows through the resistor. It all flows through the capacitor. The voltage gain is now roughly zero.
- Somewhere in between, the effect of the capacitor is equal to that of the feedback resistor. More precisely, the reactance of the capacitor equals the resistance of the feedback resistor. This happens at a frequency called the break frequency, and this marks the frequency at which the voltage gain of the filter starts to fall appreciably.
- At the break frequency:

$$X_C = R$$

so that:

$$1/2\pi fC = R$$

giving:

$$\text{break frequency } f = 1 / 2\pi RC$$

For your records:

- Why is the term 'break frequency' important when considering the behaviour of filters?
- Write down the formula for break frequency.
- Calculate the break frequency for the circuit you investigated on the previous page.

Worksheet 10

Relaxation oscillator

CP3061-10

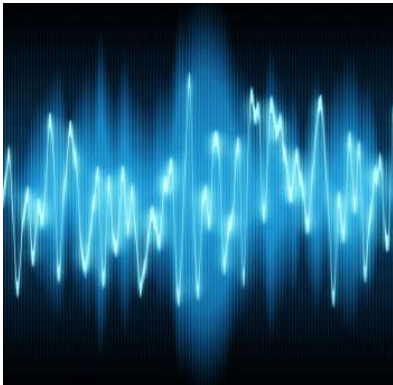

Another use for op-amps! This time, we use a combination of positive and negative feedback to make the output oscillate on, off, on, off repeatedly.

We do this twice - once with oscillations so slow that you can see them on the analogue voltmeter and on a LED, and then, with different component values, faster oscillations which you can hear on the loudspeaker.

Over to you:

1. Slow oscillations:

- Set up the circuit shown in the first diagram.
- The picture shows one way to do this. A 4mm lead is used to make the positive feedback connection.
- Switch on the power supply.
- Watch the LED and the voltmeter connected to the op-amp output, Both show a low frequency oscillation.
- The frequency depends on the values of the resistors and capacitor. Experiment with other values.

2. Fast oscillations:

- Set up the second circuit.

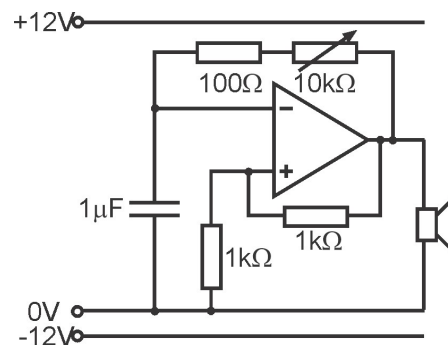
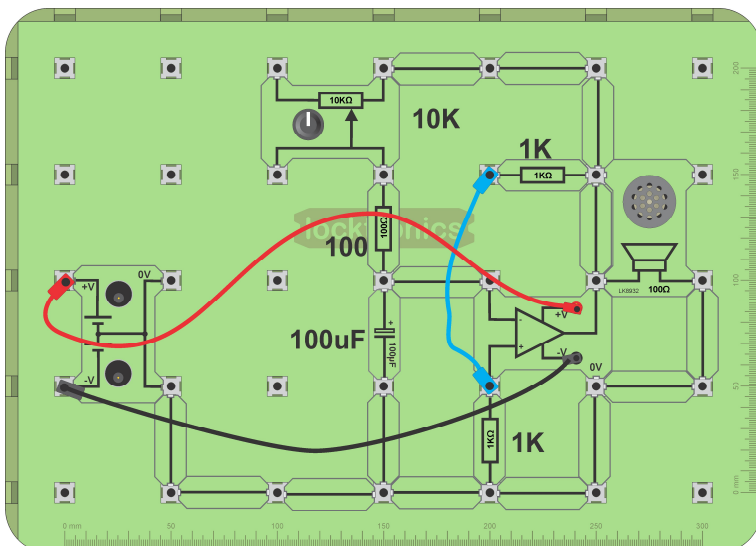
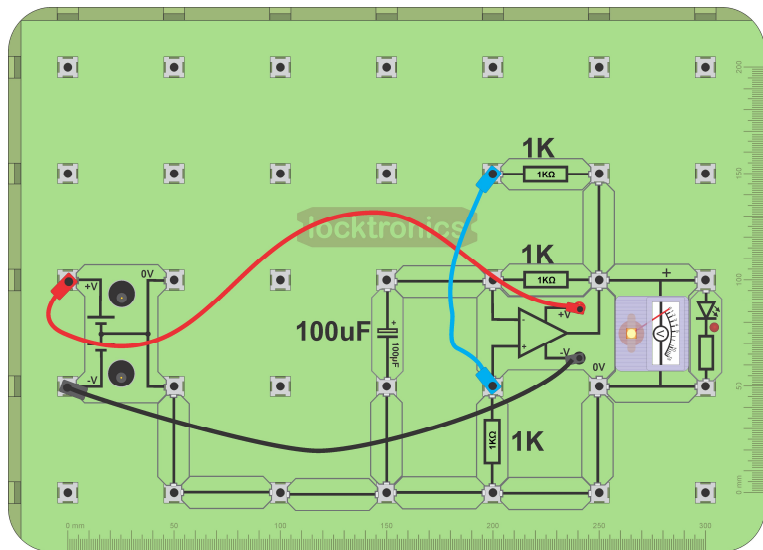
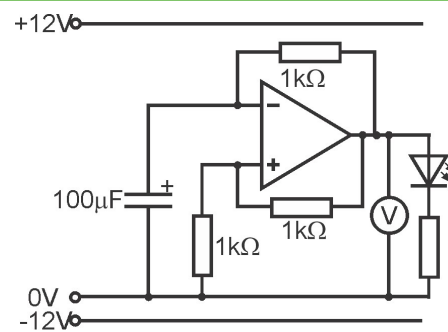

Worksheet 10

Relaxation oscillator

CP3061-10

- The picture that follows shows one way to do this, but, again, power supply details are not shown. The capacitor value has been reduced to $1\mu\text{F}$, and a $10\text{k}\Omega$ variable resistor replaces the fixed $1\text{k}\Omega$ resistor.
- The voltmeter and LED have been replaced with a loudspeaker, because this time, the oscillations are too fast to see.
- Switch on the power supply.
- Turn the knob on the variable resistor, and notice the effect.
- Again, experiment with other component values and describe how the pitch changes.

So what?

The relaxation oscillator circuit you just used has two feedback resistors. One, labelled R_1 , connected to the inverting input, provides negative feedback, and the other, connected to the non-inverting input provides positive feedback.

The two $1\text{k}\Omega$ resistors set the switching thresholds, as in the Schmitt trigger, studied in worksheet 2.

When the output is in positive saturation, the capacitor charges up through resistor R_1 .

When the voltage across the capacitor (which is V_1) reaches the upper switching threshold, the op-amp output, V_{OUT} , jumps into negative saturation.

The capacitor now discharges through R_1 . When V_1 has dropped to the lower switching threshold, the op-amp output jumps into positive saturation and the whole process repeats.

For your records:

- Draw the circuit diagram for the (slow) relaxation oscillator.
- Draw the graph showing how V_1 and V_{OUT} change with time, and relate to the upper and lower switching thresholds.
- Write an short description for an intelligent friend, who has not carried out the investigation, explaining why the circuit oscillates.
- Explain, in less than 50 words, why turning the potentiometer produced the effect which you observed.

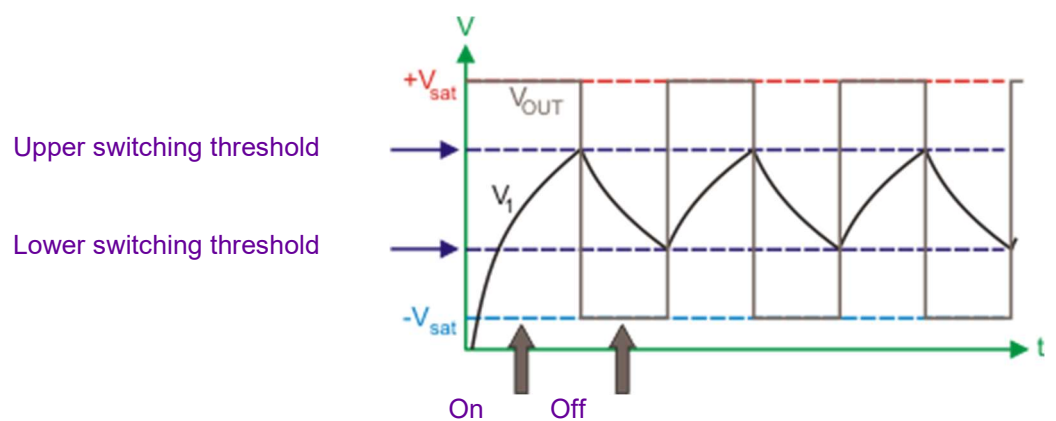
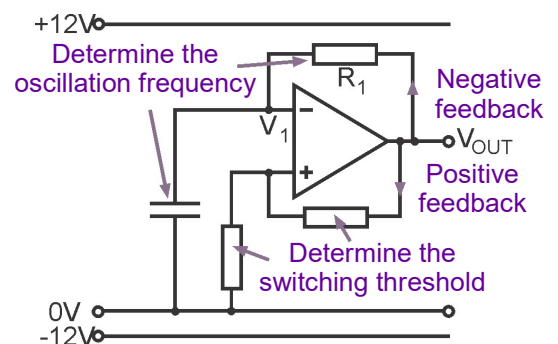

Student handout

Worksheet 1

Op-amp principles



Input voltage V_1	Input voltage V_2	Output voltage V_{OUT}
+9.0V		
+8V		
+7V		
+6V		
+5V		
+4V		

Input voltage V_1	Input voltage V_2	Output voltage V_{OUT}
+9.0V		
+8V		
+7V		
+6V		
+5V		
+4V		

For your records:

- Copy the circuit symbol for the op-amp and add labels to identify the three terminals.

- Copy the formula for voltage gain, and the basic equation for the op-amp.

- Explain what is meant by:
 - high gain differential voltage amplifier
 - saturation
 - Comparator

Worksheet 2

The comparator and Schmitt trigger



For your records:

- Draw the circuit diagram to show a temperature-sensing unit connected to :
 - a comparator circuit;
 - a Schmitt trigger circuit.

- Write a clear explanation in no more than 50 words on the difference between comparators and Schmitt triggers.

- Design a Schmitt trigger circuit like the one above but which has switching thresholds of +2V and -2V. Assume that the saturation voltages are +12V and -12V.

Worksheet 3

Non-inverting amplifier



$R_F = 1k\Omega, R_1 = 1k\Omega$		
V_{IN}	V_{OUT}	Gain
+2.5V		
+1.5V		
+0.5V		
-0.5V		
-1.5V		
-2.5V		

$R_F = 10k\Omega, R_1 = 1k\Omega$		
V_{IN}	V_{OUT}	Gain
+0.5V		
+0.3V		
+0.1V		
-0.1V		
-0.3V		
-0.5V		

For your records:

- Draw the circuit diagram for the non-inverting voltage amplifier.
- Write down the formula linking voltage gain to input voltage and output voltage.
- Write down the formula linking the voltage gain of a non-inverting amplifier to the values of the feedback resistor and resistor R_1 .
- Fill in the following table:

Input voltage	Output voltage	Voltage gain	Resistor R_F	Resistor R_1
5mV			22k Ω	2k Ω
	300mV	15		1k Ω
20mV	400mV		38k Ω	
10mV		10		10k Ω
3mV	18mV		100k Ω	

Worksheet 4

The inverting amplifier



$R_F = 10k\Omega, R_{IN} = 10k\Omega$		
V_{IN}	V_{OUT}	Gain
+2.5V		
+1.5V		
+0.5V		
-0.5V		
-1.5V		
-2.5V		

$R_F = 10k\Omega, R_{IN} = 1k\Omega$		
V_{IN}	V_{OUT}	Gain
+0.5V		
+0.3V		
+0.1V		
-0.1V		
-0.3V		
-0.5V		

For your records:

- Draw the circuit diagram for the inverting voltage amplifier.
- Write down the formula linking the voltage gain of an inverting amplifier to the values of the feedback resistor and input resistor.
- Complete the following table:

Input voltage	Output voltage	Voltage gain	Resistor R_F	Resistor R_{IN}
5mV			20k Ω	2k Ω
	-300mV	12		10k Ω
20mV	100mV		100k Ω	
-10mV		3		10k Ω
3mV	-24mV		240k Ω	

Worksheet 5

AC behaviour of amplifiers



Non-inverting amplifier

$R_f = 10k\Omega$ $R_1 = 1k\Omega$			
Frequency	V_{IN}	V_{OUT}	Gain
100	0.3V		
500	0.3V		
1000	0.3V		
5000	0.3V		

Inverting amplifier

$R_f = 10k\Omega$ $R_1 = 1k\Omega$			
Frequency	V_{IN}	V_{OUT}	Gain
100	0.3V		
500	0.3V		
1000	0.3V		
5000	0.3V		

For your records:

- Explain to an intelligent friend, who has not done this investigation, what causes clipping distortion.

- Draw a voltage / time graph to show the effect of clipping distortion on a sine wave signal.

Worksheet 6

Voltage follower



V_{IN}	V_{OUT}
+2.5V	
+1.5V	
+0.5V	
-0.5V	
-1.5V	
-2.5V	

For your records:

- Draw the circuit diagram for the op-amp voltage follower:

- Complete the following:
 - In a voltage follower, the output voltage is to the input voltage. However, the input impedance (resistance) of the voltage follower is so big that it draws current from the input signal source. As a result, it has little or no effect on the input signal. The output device draws current from the op-amp and not from the signal source.
- Use the internet to research the following terms and explain each in less than 25 words:
 - buffer;
 - 100% feedback;
 - equivalent circuit.

Worksheet 7

The summing amplifier



$R_F = R_2 = R_1 = 10k\Omega$		
V_2	V_1	V_{OUT}
+2.0V	+1.0V	
+1.5V	+1.0V	
+0.5V	-0.5V	
-0.5V	-0.5V	
-1.5V	+2.0V	
-2.5V	+2.0V	

$R_F = R_2 = R_1 = 10k\Omega$		
V_2	V_1	V_{OUT}
+2.0V	+1.0V	
+1.5V	+1.0V	
+0.5V	-0.5V	
-0.5V	-0.5V	
-1.5V	+2.0V	
-2.5V	+2.0V	

For your records:

- Copy the circuit diagram for the summing amplifier, given on the previous page.
- Copy out the steps of the analysis given above, but modify them by using the values given in the last line of the results table, where $V_2 = -2.5V$ and $V_1 = +2.0V$.
(The current will flow the opposite way in input V_2 , because the voltage is negative!)

Worksheet 9

Active treble cut filter



Frequency	V _{IN}	V _{OUT}	Gain
50Hz			
100Hz			
150Hz			
200Hz			
250Hz			
300Hz			
400Hz			
500Hz			

For your records:

- Why is the term 'break frequency' important when considering the behaviour of filters?

- Write down the formula for break frequency.

- Calculate the break frequency for the circuit you investigated.

About this course

Introduction

The course is essentially a practical one. Locktronics equipment makes it simple and quick to construct and investigate electrical circuits. The end result can look exactly like the circuit diagram, thanks to the symbols printed on each component carrier.

Aim

The course introduces students to the principles of operational amplifiers and a range of applications, through a series of experiments which allow students to unify theoretical work with practical skills.

Prior Knowledge

It is recommended that students have followed the 'Electricity Matters 1 and 2' courses, or have equivalent knowledge and experience of building simple circuits, and using multimeters.

Learning Objectives

On successful completion of this course the student will:

- identify the terminals in an op-amp, and relate them to the circuit symbol;
- recall and use the basic formula governing op-amp behaviour;
- describe the meaning and significance of output saturation;
- explain the significance of the term 'high gain differential voltage amplifier' ;
- distinguish between the performance of a comparator and a Schmitt trigger circuit;
- draw the circuit diagram for a sensing unit connected to a comparator;
- draw the circuit diagram for a sensing unit connected to a Schmitt trigger;
- analyse the behaviour of an inverting Schmitt trigger given the circuit diagram and saturation voltages;
- recall the ideal characteristics of an op-amp;
- recall and use the basic formula for voltage gain;
- draw the circuit diagram for a non-inverting voltage amplifier based on an op-amp;
- recall and use the formula linking the voltage gain of a non-inverting amplifier to the resistor values used;
- compare the performance of inverting and non-inverting voltage amplifiers in terms of input impedance;
- draw the circuit diagram for an inverting voltage amplifier based on an op-amp;
- recall and use the formula linking the voltage gain of an inverting amplifier to the resistor values used;
- use the fact that the input voltages of the op-amp are equal when the output is not saturated to test the op-amp;
- use an oscilloscope to measure the AC voltage gain of inverting and non-inverting voltage amplifiers;
- describe the purpose of a voltage follower circuit;
- describe the conditions needed to maximise signal voltage transfer between subsystems;
- draw the circuit diagram for a voltage follower based on an op-amp;
- draw the circuit diagram for a summing amplifier based on an inverting voltage amplifier;
- recall and use the formula for calculating the output voltage of a summing amplifier;
- describe the modifications needed to convert a summing amplifier into an audio mixer;
- draw the circuit diagram for a difference amplifier based on an inverting voltage amplifier;
- analyse the behaviour of a difference amplifier given the resistor values and input voltages;
- draw the circuit diagram for an active treble cut filter, to meet a given low-voltage gain and break frequency;
- draw the circuit diagram for a relaxation oscillator based on an op-amp;
- modify the relaxation oscillator circuit to make a light-level-to-frequency converter.

What the student will need:

To complete the Op-amp applications course, the student will need the parts shown in the table.

In addition the student will need:

- LK9072 Basics of electricity kit
- 1 function generator capable of generating sinusoidal AC signals with frequencies up to 10kHz.
- 1 oscilloscope with two traces.
- Students will also need a digital multimeter - DMM.

Power source:

The investigations in this module require two power sources, one AC and the other DC. The signal generator can perform the function of an AC supply.

The HP2666 is an adjustable DC power supply offering output voltages of either 3V, 4.5V, 6V, 7.5V, 9V or 12V, with currents typically up to 1A. The voltage is changed by turning the selector dial just above the earth pin until the arrow points to the required voltage. (The instructor may decide to make any adjustment necessary to the power supply voltage, or may allow students to make those changes.)

In this pack a power supply with positive and negative power rails is required. This can be achieved using two HP2666 power supplies, set at 12V output, 'back to back' with the central connection forming the 0V rail. A special carrier (LK8492) is provided which allows the two power supplies to be connected into the circuits.

Students can also use a conventional power supply with + 12V and -12V outputs and use 4mm connectors to connect these to the LK8492 dual voltage supply carrier.

Qty	Code	Description
1	HP2666	Adjustable power supply
1	HP4039	Clip on lid
1	HP5540	Deep tray
2	HP6529	BNC male to dual 4mm binding post
1	HP7750	Daughter tray foam insert
1	HP9564	62mm daughter tray
1	LK2340	AC voltage source carrier
1	LK4000	Locktronics User Guide
1	LK4002	Resistor - 100 ohm, 1W, 5% (DIN)
1	LK4663	Low power solar motor
1	LK5202	Resistor - 1K, 1/4W, 5% (DIN)
2	LK5203	Resistor - 10K, 1/4W, 5% (DIN)
1	LK5214	Potentiometer, 10K (DIN)
1	LK5222	Capacitor, 0.1uF, Polyester
9	LK5250	Connecting Link
1	LK5401	Thermistor, 470 ohm, NTC (DIN)
2	LK5603	Lead - red - 500mm, 4mm to 4mm stackable
3	LK5604	Lead - black - 500mm, 4mm to 4mm stackable
1	LK5609	Lead - blue - 500mm, 4mm to 4mm stackable
1	LK6202	Capacitor, 100uF, Electrolytic, 25V
1	LK6205	Capacitor, 1uF, Polyester
1	LK6234L	Op Amp Carrier (TL081) with 2mm to 4mm Leads
1	LK6635	LED, red, 12V (SB)
1	LK6636	LED, green, 12V (SB)
1	LK8492	Dual rail power supply carrier with 0V
1	LK8932	Speaker carrier
1	LK9438	Voltmeter +/- 7.5V

The contents of LK6906 - Operational amplifiers add-on kit

Using this course:

It is expected that the series of experiments given in this course is integrated with teaching or small group tutorials which introduce the theory behind the practical work, and reinforce it with written examples, assignments and calculations.

The worksheets should be printed / photocopied / laminated, preferably in colour, for the students' use. Students should be encouraged to make their own notes, and copy the results tables and sections marked 'For your records' for themselves. They are unlikely to need their own permanent copy of each worksheet.

Each worksheet has:

- an introduction to the topic under investigation;
- step-by-step instructions for the investigation that follows;
- a section headed 'So What', which aims to collate and summarise the results, and offer some extension work. It aims to encourage development of ideas, through collaboration with partners and with the instructor.
- a section headed 'For your records', which can be copied and completed in students' exercise books.

This format encourages self-study, with students working at a rate that suits their ability. It is for the instructor to monitor that students' understanding is keeping pace with their progress through the worksheets. One way to do this is to 'sign off' each worksheet, as a student completes it, and in the process have a brief chat with the student to assess grasp of the ideas involved in the exercises it contains.

Time:

It will take students between twelve and fifteen hours to complete the worksheets.

It is expected that a similar length of time will be needed to support the learning that takes place as a result.

Worksheet	Notes for the Instructor	Timing
1	<p>The first issue is to familiarise students with the pinout of the op-amp, and to explain the significance of the 'inverting' and 'non-inverting inputs'. At this stage, no attempt is made to introduce the offset null connections.</p> <p>The op-amp carrier uses a TL081 op-amp, which is pin-compatible on the industry-standard 'LM741' but with vastly improved characteristics, especially input impedance. The students will meet this concept later in the course. For now, they may need to have the idea of a dual-rail power supply explained to them. The physical reality is that there is no such thing as 0V in this circuit. Although the power rails are labelled +6V / 0V / -6V, that is simply to conform to convention. They could equally well be labelled 12V / 6V / 0V. However, the convention is that voltages are measured from the centre voltage, and this is called 0V.</p> <p>The aim of the first part of the investigation is merely to show that the output switches rapidly from one extreme (saturation voltage) to the other as the input voltage changes relative to the reference voltage set by the two equal resistors.</p> <p>The second stage measures the input voltages to investigate more closely this changeover. Students should be able to use a digital multi-meter to measure voltage, though the instructor may have to remind them how to do this.</p> <p>Finally, the student swaps over the inputs to see the effect.</p> <p>The 'So what?' section explains the significance of the description 'high gain differential voltage amplifier' and gives the formulae for voltage gain and for the basic behaviour of the op-amp. At this stage, there is no mention of feedback. The role of this circuit as a voltage comparator is described, but this may need to be driven home through a number of examples.</p>	30 - 45 mins
2	<p>In worksheet 1, students met the comparator. In this worksheet, they attach a temperature-sensing unit to one of the inputs, and a variable reference voltage, provided by a 'pot', to the other.</p> <p>Although students should know the difference between a variable resistor and a potentiometer, they may need the instructor's help to set up the 'pot'. In particular, the instructor should check that the 10kΩ resistor, and not the 'shorted' output, is connected between the power supply rails. A simple rule is that resistors have two 'legs' and so do variable resistors. The 'pot' uses all three legs.</p> <p>The secret of success is to adjust the 'pot' so that the LED is about to turn off. The slightest change to the temperature of the thermistor should then make that change happen.</p> <p>The investigation then turns to the Schmitt trigger circuit. The aim is that students realise that the single switching threshold of the comparator can cause problems when the output of the sensor is subject to high levels of electrical noise, or any other factor that causes the output voltage to 'wobble'. When near the switching threshold, this variation may be enough to make the output switch rapidly from one saturation value to the other. This 'hunting' can have serious consequences for the device attached to the output of the comparator, or to the comparator itself, as current demand rises sharply when switching takes place.</p>	30 - 45 mins

Worksheet	Notes for the Instructor	Tim-
2	<p>continued...</p> <p>The Schmitt trigger overcomes this problem by having two switching thresholds. The output switches from negative to positive saturation at a low voltage, but stays there even if the voltage rises slightly (i.e. no hunting.) The output changes back only if the input rises to a relatively high voltage, (but then stays there even if the input fluctuates.) The circuit studied is known as an inverting Schmitt trigger. There is a non-inverting Schmitt trigger, but its analysis is a bit more complicated. Able students could be given the task of researching that circuit.</p>	
3	<p>Now the students meet feedback. The instructor might wish to expand on the ideas of positive and negative feedback, as both are used in this module.</p> <p>Negative feedback always produces a calming effect on the circuit. It makes the output less likely to saturate. It reduces the huge open-loop voltage gain of the op-amp to a more manageable level. The idea of an amplifier is that the output follows the input, but is a larger version of it. If the output saturates, it can no longer follow changes in the input. Amplifiers use negative feedback, as their outputs should never saturate.</p> <p>Positive feedback, on the other hand, drives the output into saturation more readily, making it unlikely that the output is ever out of saturation. It is used in oscillators and Schmitt triggers, where the output is required to be in one value of saturation all the time.</p> <p>While amplifiers are usually associated with audio systems, it makes sense to begin the investigation by using DC signals. These are easier to visualise and, probably, to measure. As students will discover in worksheet 5, these amplifiers have the same behaviour for DC and for low frequency AC signals.</p> <p>The voltage gain of the amplifier is determined solely by the value of the two resistors, R_F and R_1, provided extreme values of gain or bandwidth are avoided. This investigation looks at two pairs of resistor values, to give gains of 2x and 11x. The instructor may wish to add other values, or vary the values between different groups and then later collate results.</p> <p>Students often confuse the voltage gain formula ($= V_{OUT} / V_{IN}$) and the voltage gain formula showing the dependence on resistor values ($= 1 + R_F/R_1$.) Instructors should provide a range of examples to reinforce the significance of these formulae.</p> <p>The analysis in 'So what?' introduces the ideal characteristics of op-amps. These will need a deal of reinforcement by the instructor, as some are fairly esoteric concepts. The important idea in there is the input impedance. As we are dealing with DC signals, this can be called input resistance here. The significance is that many signal sources can generate a reasonable voltage, but are unable to deliver appreciable current. If the amplifier draws much current from these sources, the voltage transferred to the amplifier will be very small. Most of the signal voltage will be dropped across the output (but internal) resistance of the signal source. The big advantage of the non-inverting amplifier over the inverting amplifier is that the former has a much higher input impedance, and so draws a much smaller current from the signal source.</p>	35 - 50 mins

Worksheet	Notes for the Instructor	Timing
4	<p>This investigation mirrors that in worksheet 3, but uses an inverting amplifier. The formula for voltage gain is applied to the results. The formula linking voltage gain to resistor values is given without proof, but will need additional examples to cement it into the students' minds.</p> <p>The 'So what?' section includes an important practical detail, that for any op-amp circuit where the output is not saturated, the two inputs sit at virtually the same input. Some students might puzzle at the role of the op-amp in the two voltage amplifier circuits. The voltage gain formulae make no mention of it! The answer is that the op-amp is trying its hardest to keep the two inputs at the same voltage. If the output saturates, then it has failed.</p> <p>Here is a very practical means of checking that the op-amp is functioning properly. Provided the output is not saturated, a DMM connected to first one and then the other input should give the same reading.</p> <p>The point is also made that the input resistor, R_{IN}, should be as large as is practicable in order to keep a high input resistance for the amplifier (which really is equal to the value of the input resistor.)</p>	30 - 40 mins
5	<p>Earlier worksheets evaluated the DC performance of non-inverting and inverting voltage amplifiers. Now we look at their AC behaviour. The hardware involved is more demanding to operate, and some students will need help in configuring the signal generator and Picoscope.</p> <p>The aim is to measure the voltage gain of these amplifiers at a number of frequencies. These are kept low enough so that the open-loop gain of the op-amp is still huge. The instructions specify an amplitude for the input signal of 0.3V, but the instructor may wish to change this to match the equipment used. It should be kept reasonably small, certainly to begin with, to avoid output saturation.</p> <p>Students are later invited to increase the amplitude of the input until they see the output hit saturation. The effect on the shape of the output signal should be studied. It is known as clipping distortion. Hearing the effect is slightly disappointing, as the central note is still heard, but it sounds harsher because of the higher frequencies introduced in the clipping process.</p> <p>The worksheet suggests values for the Picoscope oscilloscope. Students can use this investigation to practice changing these settings. Instructors may wish to point out the significance of timebase and voltage sensitivity settings, and could usefully point out the difference between the trigger options. While investigating the effect of changes, 'Auto' is a useful trigger setting. When the student is ready to capture the signal, 'Single' is useful, as it is a one-shot situation. If the result is not satisfactory, clicking on 'Go' repeats the scan, and will eventually produce a satisfactory trace..</p>	

Worksheet	Notes for the Instructor	Timing
6	<p>The name ‘voltage follower’ describes what the subsystem does, but sounds rather boring. It disguises the subtlety that this is much more than a simple piece of wire that transfers a voltage from input to output. Its importance lies in its impedance matching function.</p> <p>The first part of the investigation demonstrates the piece of wire effect - $V_{OUT} = V_{IN}$. The second part shows the more subtle effect. This can be done in other ways, depending on the equipment available to the students. Here it is shown that when the temperature-sensing unit is connected directly to the fan motor, the latter has such a low impedance (resistance) that the voltage signal from the sensing unit collapses, and the motor does not turn. Using the voltage follower to interface the motor and sensing unit rectifies this. The current delivered to the motor is drawn from the power supply to the op-amp. This current is controlled by the signal from the temperature-sensing unit. Students may need to dwell for a while on this concept, and the instructor should be ready to explain what is going on.</p> <p>The ‘So what?’ section goes into detail about voltage transfer between subsystems, but students may need help in understanding this idea. Instructors should point out that when the signal is passed to the output transducer, loudspeaker for example, then power transfer is probably more important, i.e. the requirement is to transfer not only a high voltage but also a large current. That changes the rules radically!</p> <p>Another area where reinforcement may be needed is that of 100% negative feedback. The initial reaction of the student may be that if the full output signal is subtracted from the input signal, then nothing is left!</p>	35 - 45 mins
7	<p>Once again, the title describes what this subsystem does. However, it does so only if equal-sized resistors are used throughout! Students should find that the early part of part 1, the summing amplifier, works as expected, but that the second part, where the value of the feedback resistor is reduced to $1k\Omega$, produces a more thought-provoking effect. In practice, this is an amplifier, and so we need to avoid output saturation. The output sums the input signals, and may add a weighting factor. As a result, it is easy to cause saturation. To avoid it, keep the voltage gain to a small value by reducing the size of the feedback resistor.</p> <p>In part 2, the circuit is modified slightly by adding a variable resistor in series with each of the input resistors, to allow the effective input resistance to be changed. It is now an audio mixer. What surprises some is that to increase the presence (loudness) of a signal at the output, its input variable resistor value should be reduced. The instructor may need to spend time assigning values to the variable and fixed resistors to demonstrate this point. In this part. The student applies AC audio signals to the inputs, and observes the effect on the loudspeaker of changing the variable resistor values. Once again, some will need help in setting up the circuit, as widespread confusion about variable resistors may persist even after worksheet 2!</p> <p>The fine details for the mixer depends on the instructor (and on the equipment available.) The worksheet suggests using a MP3 player to provide one signal, and a microphone to provide the other. Alternatively, signal generators producing different frequencies can be used.</p>	

Worksheet	Notes for the Instructor	Timing
8	<p>The difference amplifier is the same, but different! The function is suggested by the name. However, its major application is as an instrumentation amplifier. These have to amplify the significant section of the signal presented to them by sensors, while rejecting unwanted components caused by electrical noise, or temperature variations etc.</p> <p>Students are asked to notice the symmetry of the circuit diagram. This may help them to remember how to draw it. The instructor may wish to emphasise this feature to the students.</p> <p>The instructions suggest suitable values for the input voltages, but the instructor may wish to vary these, or allocate different values to different groups. As usual, the danger is that the output saturates, and the instructor should take care to avoid this when selecting voltage or resistor values.</p> <p>Students are asked to deduce a relationship between output and input voltages and then to test their ideas by predicting the output for a new set of input voltages. Equally, the instructor could give them the input voltages and ask them to work out the corresponding output.</p> <p>The 'So what?' section analyses the behaviour of the circuit by re-drawing the two input circuits, assuming that no current flows into the op-amp inputs i.e. assuming that the op-amp is ideal and so has infinite input impedance. This analysis is not easy, and the instructor should spend time going through it with the students, and getting them to work on similar arrangements that use different voltages and/or resistor values.</p>	
9	<p>So far, we have assumed that the frequency of the input signal is unimportant. We would like to think that an audio amplifier treats all audio frequencies equally (i.e. with the same voltage gain.) However, there are times when we want to boost or cut certain ranges of frequencies to 'improve' sound quality. This investigation looks at one of a large number of circuits that does this.</p> <p>The term 'active' means that the voltage gain can be greater than unity for some frequencies. The alternative is to use a 'passive' filter where the voltage gain is always less than unity.</p> <p>'Treble' means the high end of the audio frequency range, but is a rather vague term. The alternative is 'bass', the low end of the audio frequency range. (Sometimes the term 'mid-range' is also used for the section in between.) Filters can 'cut' (reduce gain,) or 'boost' (increase gain,) though passive filters can only cut. This investigation looks at the behaviour of an active treble cut filter. The frequency effect is controlled by a resistor - capacitor combination. In this case it is a $0.1\mu\text{F}$ capacitor connected in parallel with a $10\text{k}\Omega$ resistor in the feedback circuit. The same placed in the input circuit instead would produce a treble boost filter. Connecting the resistor - capacitor in series instead would produce a bass boost filter if they were in the feedback circuit, and a bass cut filter if they were in the input circuit. The other resistor helps to decide the 'flat' gain, using the usual formula for an inverting amplifier ($-R_F / R_{IN}$)</p>	

Worksheet	Notes for the Instructor	Timing
10	<p>This circuit uses both positive and negative feedback, and the instructor might want to point out the components used to deliver these. The circuit is a useful way to generate square waves that swing from close to one voltage rail to close to the other.</p> <p>The frequency of oscillation is determined by the resistor - capacitor pair in the negative feedback loop. The switching thresholds are determined by the two resistors used in the positive feedback loop. More able students could be asked to investigate changes in both of these.</p> <p>The instructor may wish to connect a Picoscope to the output, and to input V_1, to demonstrate the behaviour described in the 'So what?' section. In any case, the analysis is quite complicated and needs the instructor's intervention to ensure that it is understood.</p> <p>The investigation uses different values of components to produce firstly an oscillation that is slow enough to observe on a LED or analogue meter, and secondly of a frequency high enough to produce an audible tone from a loudspeaker.</p> <p>As an extension, the student could be invited to replace the resistor with a LDR or any other sensor whose resistance depends on an external factor - e.g. a thermistor or pressure transducer. This circuit represents whatever factor it is as a changing audio frequency. The instructor could invite applications of this effect from the students.</p> <p>In some countries, an LDR may not be available due to RoHS legislation. Unfortunately, the usual substitute component - a phototransistor - is not suitable in this circuit because it does not behave as a true resistor.</p>	

Version control



CP3061-1 27 09 23	Op-amp principles First release
CP3061-2 27 09 23	Op-amp principles First release
CP3061-2 27 09 23 01 11 23	Op-amp principles Reformatted Full check - worksheet reformatting.