

locktronics

Simplifying Electricity

Intermediate electronic engineering

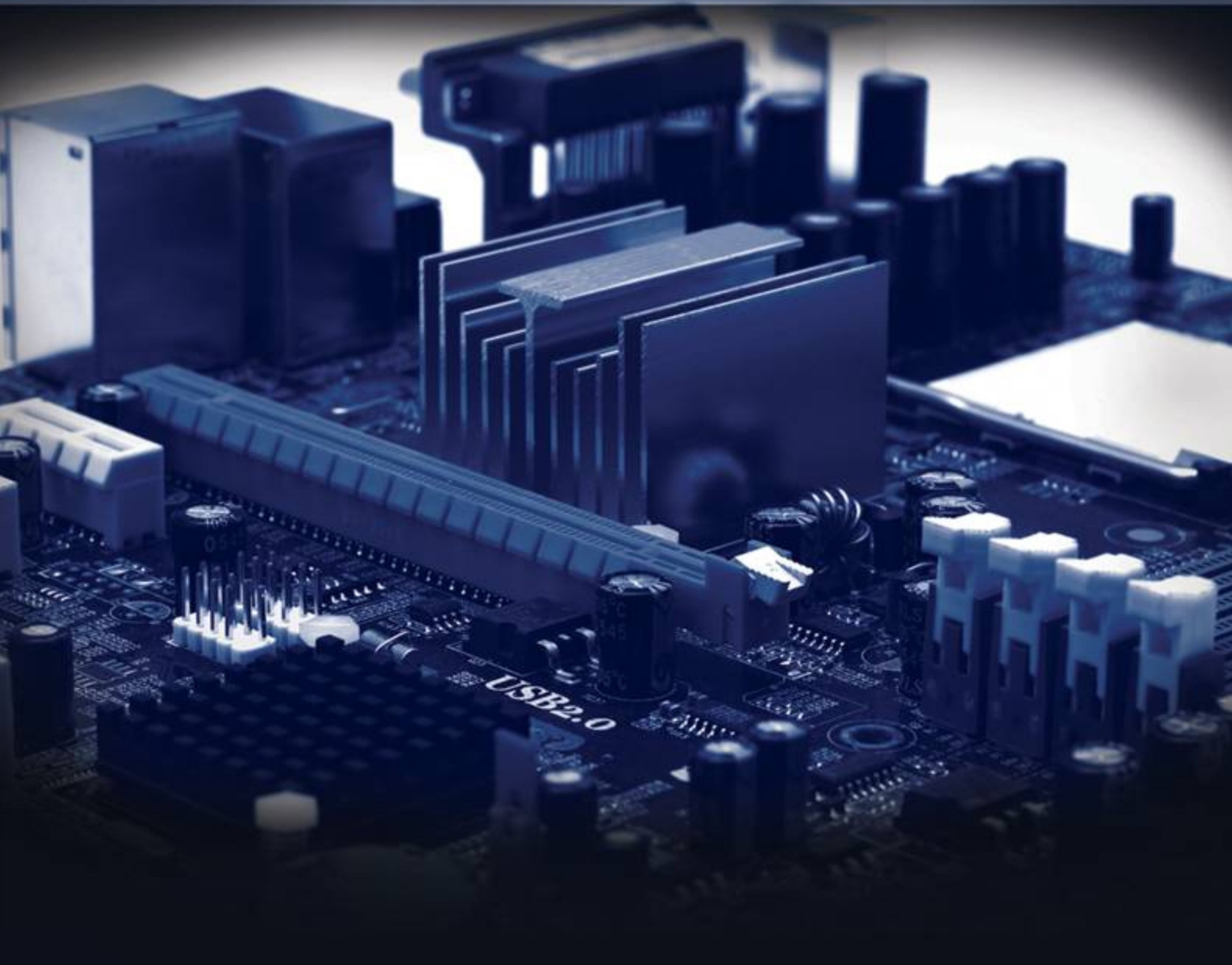

CP8293

MATRIX
www.matrixmultimedia.com

Copyright © 2009 Matrix Multimedia Limited

Worksheet 1 - Analogue versus digital	3
Worksheet 2 - Symbols and circuits	5
Worksheet 3 - Resistors	7
Worksheet 4 - Switches	9
Worksheet 5 - LDRs and thermistors	11
Worksheet 6 - LEDs and diodes	13
Worksheet 7 - Series and parallel circuits	15
Worksheet 7 - Logic gates	17
Worksheet 9 - The AND function	19
Worksheet 10 - The OR function	21
Worksheet 11 - Combinational logic with NAND	23
Worksheet 12 - Combinational logic with NOR	26
Worksheet 13 - Testing transistors	28
Worksheet 14 - Transistor as a switch	30
Worksheet 15 - Transistor as an amplifier	32
Worksheet 16 - Non inverting amplifier	34
Worksheet 17 - Inverting amplifier	36
Worksheet 18 - Timers	38
Worksheet 19 - Simple radio transmitter	40
Worksheet 20 - Simple radio receiver	42
Quiz	44
Instructor's Guide	46

Worksheet 1

Analogue vs digital

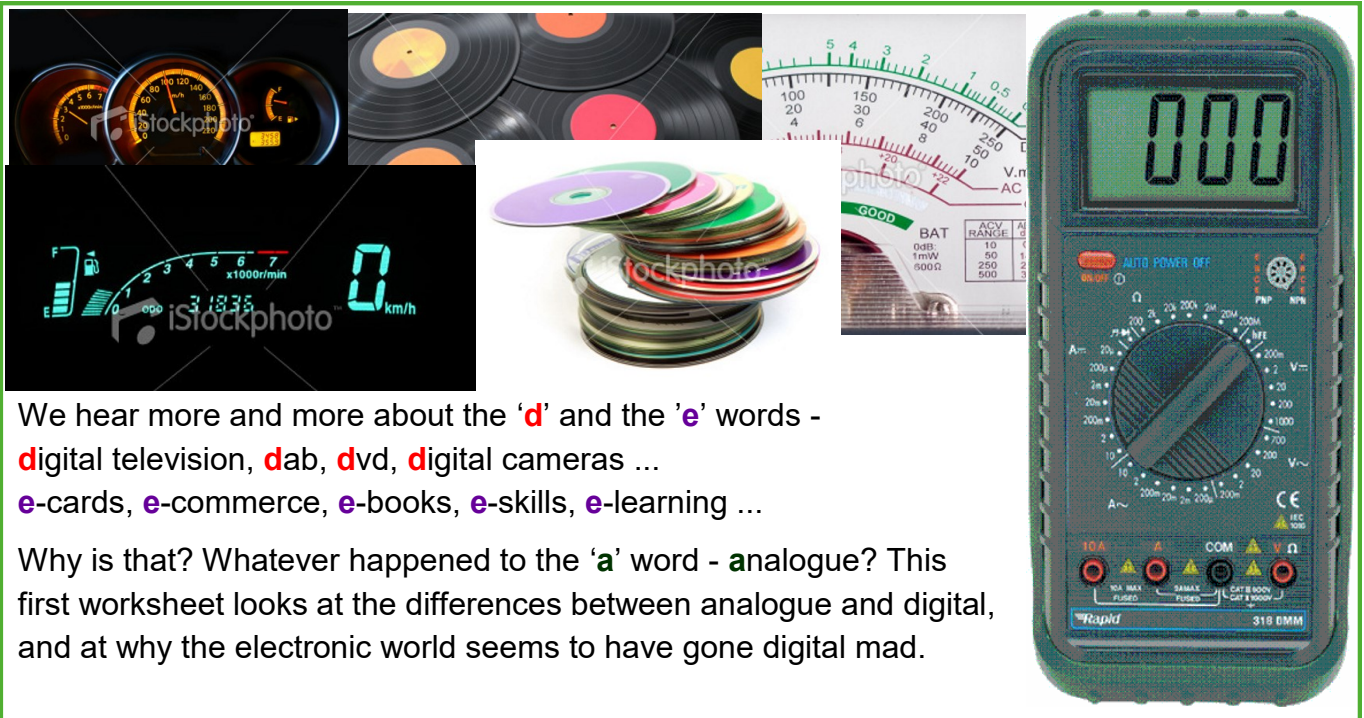

We hear more and more about the 'd' and the 'e' words - digital television, dab, dvd, digital cameras ... e-cards, e-commerce, e-books, e-skills, e-learning ...

Why is that? Whatever happened to the 'a' word - analogue? This first worksheet looks at the differences between analogue and digital, and at why the electronic world seems to have gone digital mad.

Over to you:

The first circuit uses an analogue sensor, a photo-transistor, connected in series with a 50kΩ resistor, to make a light-sensing unit.

- Set up the circuit shown opposite.
- Set the DC power supply to 6V, and switch it on.
- Set the multimeter to read voltages up to 20V DC. The symbol for DC is shown underneath the picture. Switch it on.
- Vary the amount of light reaching the sensor by slowly lowering your hand over it.
- What do you notice about the output voltage?

Now set up the second circuit, a digital sensing unit, using a switch unit. All you need to do is replace the phototransistor with a switch.

- Measure the output voltage when the switch is open (off) and again when it is closed (on).
- Invert the switch unit. All this means is swap over the switch and the resistor. Measure the output voltages again, when the switch is closed and open.

Compare the behaviour of the analogue and digital circuits.

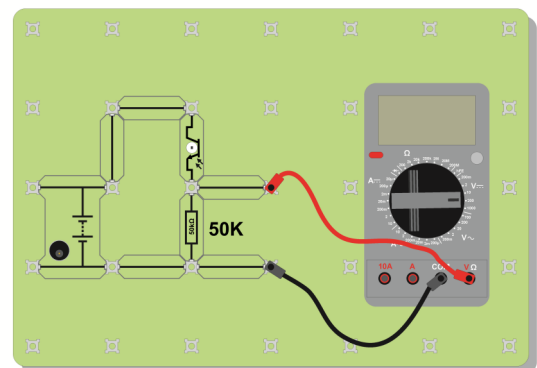

DC 

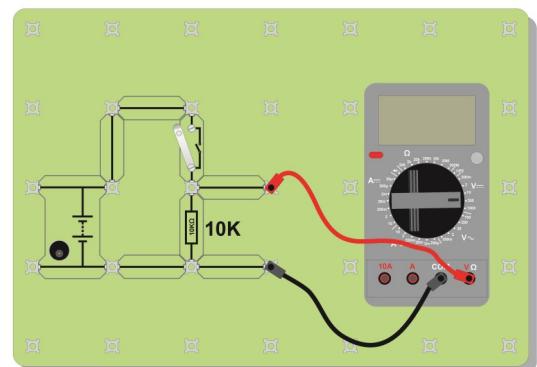

Worksheet 1

Analogue vs digital

So what?

An analogue sensor gives an analogy - a copy of the behaviour it is sensing. For the light-sensing unit, as the light level goes down, the output voltage goes down. The voltage mimics the light level. As we can change the light level by very small amounts, so we can change the output voltage by very small amounts.

A digital sensor, on the other hand, is a two-state affair. A switch is either on or off - just two possible states. The output voltage, as a result, has one of only two possible values.

These ideas are shown in the graphs opposite. The top one shows an analogue signal. It changes continuously as the light intensity changes. The lower graph must be plotted in a different way. The state of the switch does not change smoothly from off to on. It can't be slightly on, and then a bit more on, and so on. It is **on** or **off**. The horizontal axis shows the time at which the change from on to off occurs. The output voltage always has one of two possible values.

The vocabulary of digital electronics talks about these two voltages as 'logic 0' and 'logic 1'. Somewhere in a particular design, these will be defined, usually as a range of possible

voltages. For example, logic 0 may be defined as any value between 0V and 1.0V, while logic 1 is any value between 10.0V and 12.0V. Giving a range of values recognises that signals can change a little as they move through an electronic system.

A major advantage of digital signals is that we, and electronic systems themselves, can make a pretty good guess at what the signal should be. For example, suppose a signal arrives with a voltage of say 8.7V. We'd guess that it was really logic 1. This ability to recreate the original signal is called **regeneration**, and is one of the major benefits of digital signals. Analogue signals do not allow us to do this.

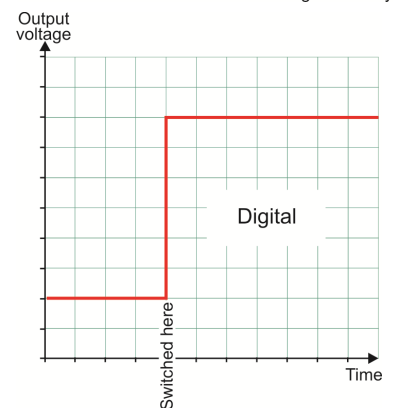
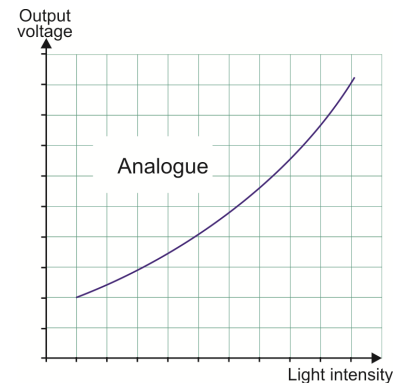

For your records:

- An analogue quantity is one that copies the behaviour of another.
- An analogue signal can have any voltage value, usually between the voltages of the power supply rails.
- A digital quantity has only two possible states. A switch, for example can be off or on.
- A digital signal has only two possible voltage values, usually known as logic 0 and logic 1.
- This allows a digital signal which has been affected by noise or distortion to be regenerated - returned to its original value.
- Analogue signals cannot be regenerated in this way.

Worksheet 2

Symbols and circuits

Everyday, you come across **symbols**, used at home or when you are out and about. They are quicker to read than long messages using words! Circuit symbols are used to identify the components used in a circuit, and to show how they are connected.

In the picture opposite, the language may be difficult to understand, but the symbols are not!



A circuit might look like this:

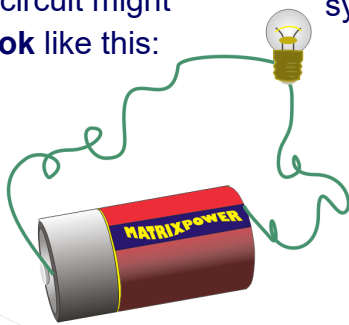

It is simpler to draw using symbols:

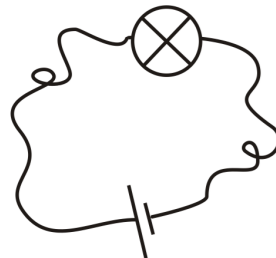

or, better still,:

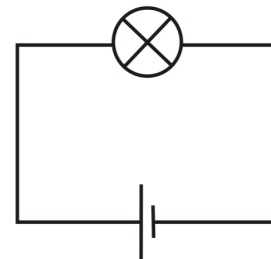

Over to you:

- Build the circuits shown in the diagrams below, using 12V 0.1A bulbs.
- The power supply voltage is given in each circuit diagram.
- Work out the answers to the questions.

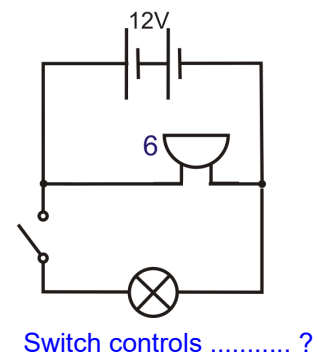
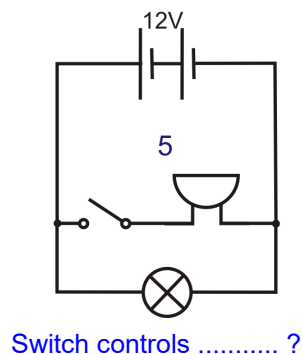
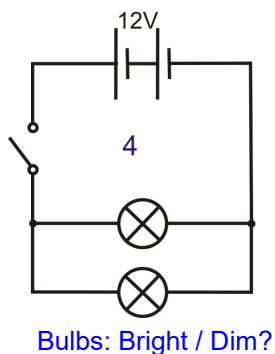
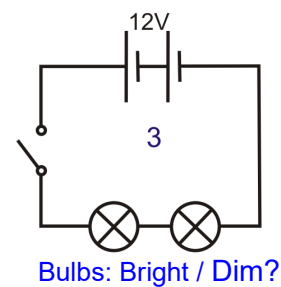
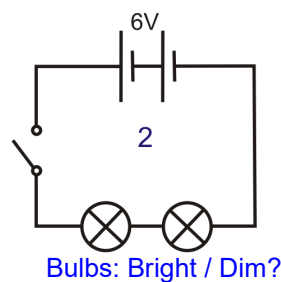
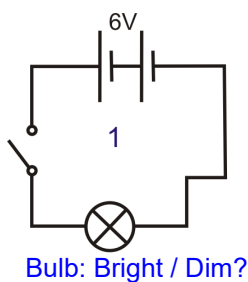

Worksheet 2

Symbols and circuits

So what?

It is much quicker and easier to describe what is in a circuit by drawing a diagram using symbols. However, you must use symbols that everyone understands.

Look at the two circuits, **A** and **B**. Compare them. Are they the same?

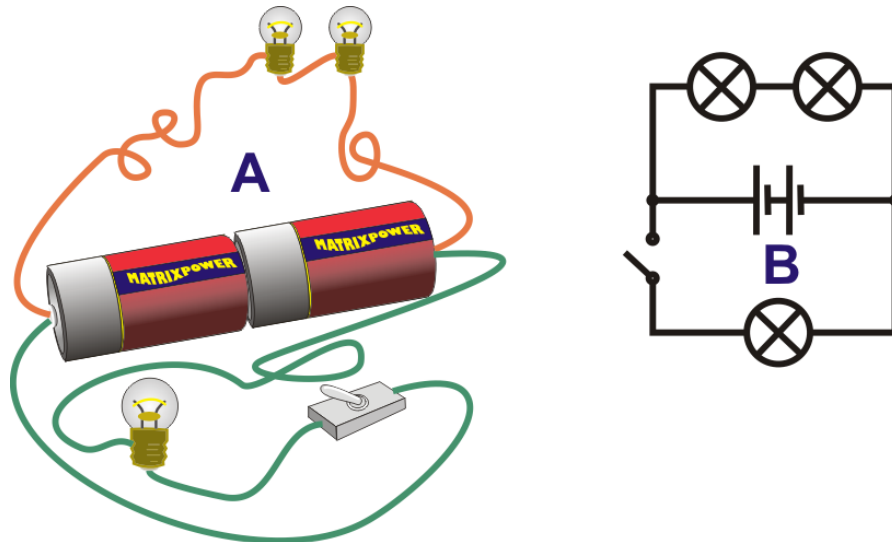

For your records:

Copy the following table. You have seen the buzzer, or sounder, in the circuits above. You will learn about the resistor soon.

Battery	Toggle switch	Lamp	Fuse	Resistor	Sounder
Supplies electrical energy	Allows a circuit to work	Turns electricity into light	A safety device	Controls the amount of current	Turns electricity into sound

Worksheet 3

Resistors

Electric currents can cause a variety of effects – heating, lighting, magnetism and chemical.

Although we cannot see them, tiny particles called electrons make up electric currents. The flow of these electrons can be reduced by adding more resistance to the circuit. The effect is like you trying to run in mud!

Using a tap, we can change the flow of water from fast to slow. With electricity, we change the flow using resistors. In this worksheet we use light bulbs to illustrate the effect of resistance on the current flowing in a circuit.



w3a

Over to you:

- Build the first circuit, using a 12V bulb.
- Set the power supply to 12V and then switch on.
- Notice how bright the bulb looks. Remember – the brighter the bulb, the greater the current flowing.
- Now modify the circuit by connecting a second bulb in series with the first bulb, as shown in the second diagram.
- Once again switch on and notice what happens to the brightness.
- What can you say about the current flowing in the circuit when the two series-connected bulbs are present?
- This is caused by the increase in **resistance** when two bulbs are connected in series. What happens when you added a third bulb in series with the other two?
- Now remove one of the bulbs and replace it with a 100Ω resistor. You now have the third circuit shown opposite.
- Switch on and once again notice how bright the bulb looks.
- Finally, replace the 100Ω resistor with a 1kΩ resistor. With this much resistance in the circuit the bulb shouldn't glow at all!

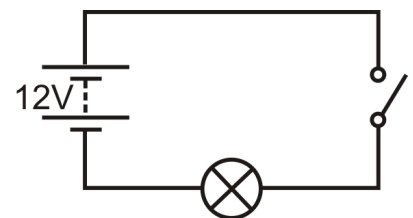

w3b

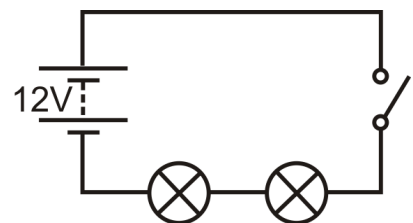

w3c

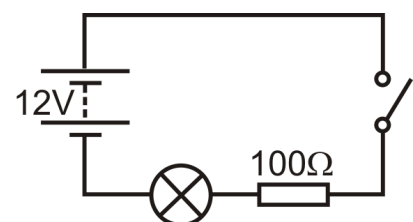

w3d

Worksheet 3

Resistors

So what?

- Adding more resistance to a circuit makes the electric current smaller.
- It is not only 'resistors' that have resistance – pencil lead, bulbs, even the wires themselves and the power supply have some resistance.
- Here are two types of symbols used for fixed value resistors:

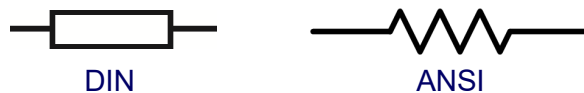

- The units used for resistance are **ohms** (Ω).
- A **short circuit** (i.e. a perfect conducting path) has a resistance of zero ohms.
- An **open circuit** (i.e. a path that conducts no current at all) has infinite resistance.
- The value of a resistor can be marked using a **colour code**.

Here is the colour code for a four-band resistor:

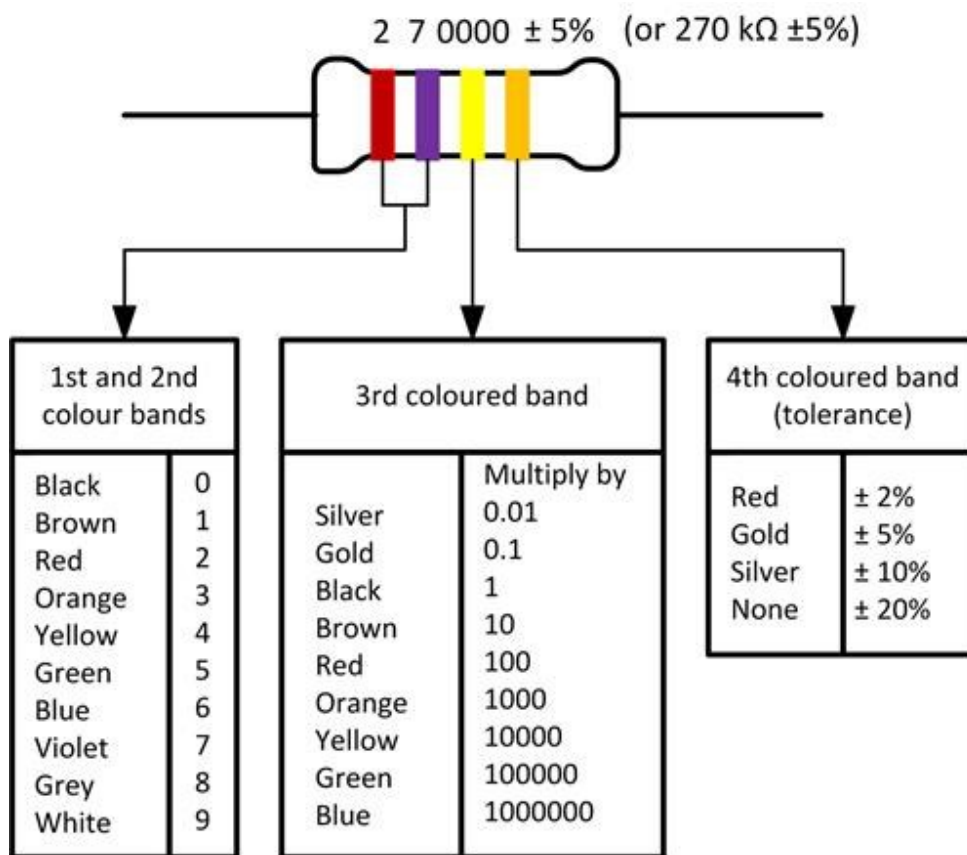

For your records:

- A resistor limits the flow of electricity
- The bigger the resistance, the smaller the electric current.
- Resistance is measured in ohms. Usually, we just use the Ω sign to mean 'ohms'.
- A resistor can be simply a long piece of wire, made from a metal that does not conduct very well. This kind is usually wound as a coil around an insulating core. It can also be made by coating an insulating core with a thin layer of carbon, or by mixing carbon with a ceramic substance (like clay.)

Worksheet 4

Switches

Have you ever been told not to leave lights on?

Leaving them on wastes energy, and money!
We need something to control the flow of electricity. A switch does just that!

A switch starts and stops the flow of electricity.

Look at the picture below!

It shows how a switch works.

Can you see what will happen when you press the switch and the lever moves down?

Remember – air is an insulator!

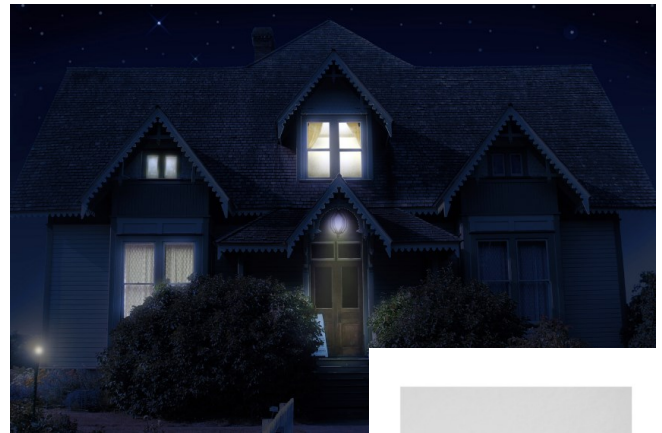

w4a

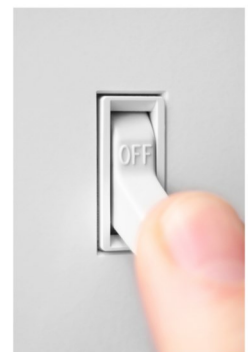
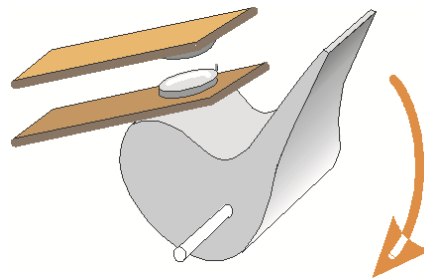

w4b

w4c

Over to you:

- Set up the circuit shown in the diagram, using a 12V bulb.
- Close the switch, and see what happens.
- Change the circuit so that there are two bulbs in it, and the switch controls both bulbs.
- Now change the circuit again so that the switch controls only one bulb - the other bulb should be lit all the time.

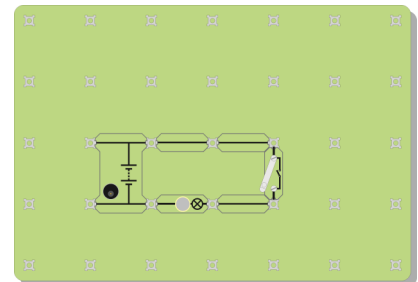

w4d

Worksheet 4

Switches

So what?

- A switch starts and stops the flow of electricity.
What stops the electricity from flowing when the switch is open?
- Does it matter where the switch is placed in the first circuit?
Explain your answer to your partner, and then do an investigation to see if you were right.

The diagram on the right shows the symbols used for two kinds of switch. A push switch is 'on' only as long as you are pressing it. When you turn on a toggle switch, it stays on, until you turn it off.

Here are two pictures of switches—a doorbell switch, and a light switch. Decide which is the toggle switch and which the push switch.

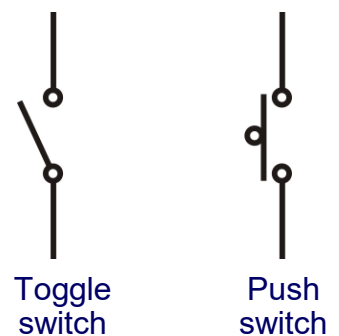

For your records:

- A switch starts and stops the flow of
- When the switch is open, the gap stops the flow of electricity.
- When the switch is, the air gap disappears, and electricity flows around the circuit.
- A toggle switch stays on or stays off all the time. A push switch is on only as long as you press it.
- A doorbell is one type of switch.
- A light switch is one type of switch.

Worksheet 5

LDRs and thermistors

This investigation focuses on two very useful types of sensor, the phototransistor and the thermistor, or 'temperature-dependent resistor'.

These form the basis for light sensing and temperature sensing units, used to monitor and control a wide range of industrial and domestic systems.

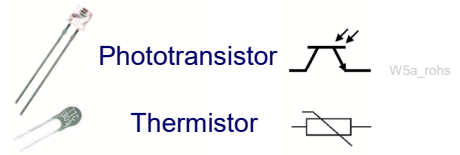

Over to you:

The first task is to measure the resistance of a thermistor at different temperatures. This is done by first heating it gently with a hair dryer. Then, it is allowed to cool slowly. As it does so, the resistance of the thermistor and its temperature are monitored.

- Fix the tip of a digital temperature probe, or thermometer, to the thermistor using a small bead of plasticine.
- Set the multimeter on the 20k Ω ohmmeter range.
- Connect it to the thermistor using the 'COM' and 'V Ω ' sockets.
- With the hair dryer on a low heat setting, warm the thermistor up slowly to just over 60°C.
- Switch off the hair dryer.
- Measure the resistance of the thermistor every 5°C, as it cools, until it reaches room temperature again.
- Record your results in a table like the one shown.

Take care when using the hair dryer.
Always keep it on a low heat setting.
Make sure that it is switched off after use.



A challenge!

Design an experiment to investigate how the resistance of a phototransistor depends on the intensity of light falling on it.

You will need a way to produce, and measure, different intensities of light. The phototransistor must be shielded from other sources of light.

Discuss your ideas with your partner and then with your instructor.

Temp in °C	Resistance in Ω
60	
55	
50	
45	
40	
35	
30	
25	
20	

Worksheet 5

LDRs and thermistors

So what?

- Plot a graph to show the results of your thermistor investigation.
- Resistance is plotted on the vertical axis and temperature on the horizontal axis. Choose suitable scales to match the range of your readings.
- Draw a smooth curve, using your plotted points as a guide.
- The result should resemble the one in the diagram below.

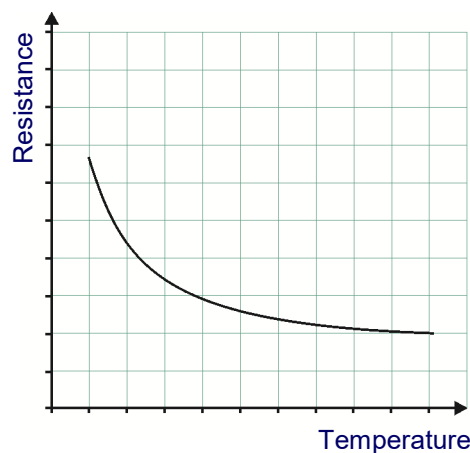

NTC vs PTC:

As the temperature drops, the resistance of the thermistor increases.

This kind of thermistor is called **NTC** (negative temperature coefficient.)

You can buy **PTC** (positive temperature coefficient.) thermistors, in which the resistance drops when the temperature drops, and rises as the temperature rises.

For your records:

• Copy the following diagram:

• A NTC thermistor has a resistance which falls as the temperature rises.

• A PTC thermistor has a resistance which increases as the temperature rises.

• The resistance of a phototransistor falls as the light intensity increases.

Phototransistor



Thermistor



Worksheet 6

LEDs and diodes



Resistors behave in a straightforward way - double the current, and you double the voltage; quarter the current and you quarter the voltage, and so on. This is known as Ohm's law.

Very few components really behave in this way. Here is one that does **not** - the diode. There are two common forms of diode - the power diode, widely used in power supply circuits, and the light-emitting diode (LED), commonly used as an indicator.

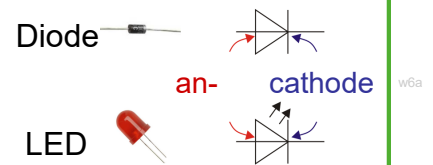

Over to you:

The power diode:

- Build the arrangement shown in the diagram. Select the 20mA DC range for the ammeter, and 20V DC range for the voltmeter. With the anode connected to the positive end of the power supply, as here, the diode is *forward-biased*.
- **Set the power supply to 3V DC, and switch on!**
- The variable resistor allows us to change the voltage applied to the diode. Turn the variable resistor knob fully anticlockwise, to reduce the voltage to zero, then slowly clockwise until the current reaches 1.0mA.
- Read the diode voltage, and record it in a table like the one shown.
- Turn the current up to 2.0mA, and measure the voltage again.
- **Be careful - turn the variable resistor knob very gently!**
The current changes rapidly for a tiny change in voltage.
- Increase the current in 1mA steps, up to 10mA, recording the voltage reading each time.

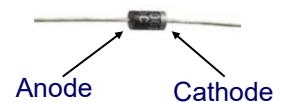
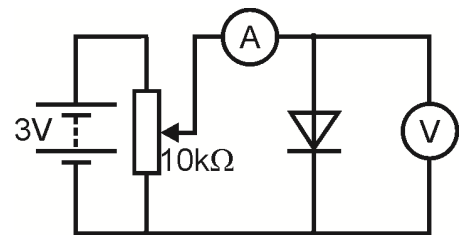

Diode current	Diode volt-
1.0mA	
2.0mA	

- Remove the diode, and replace it the other way round. It is now *reverse-biased*.
- Switch on the power supply, and turn the knob on the variable resistor slowly, to increase the supply voltage to its maximum value. Notice the current reading on the ammeter as you do so! (No need to plot this on a graph!)

The LED:

- Using the same circuit, replace the diode with the LED connected so that it is forward biased. (On a LED, the cathode is the shorter leg.)
- Repeat the investigation, but this time increase the current in 0.2mA steps, to a maximum of 2.0mA.
- Measure the voltage at each step and record your results in a second table.
- Connect the LED the other way round, and check its behaviour when reverse-biased.



Worksheet 6

LEDs and diodes

So what?

- Plot graphs to show your results for both the power diode and the LED.
- Draw smooth curves, like the one shown, using your plotted points to guide you.

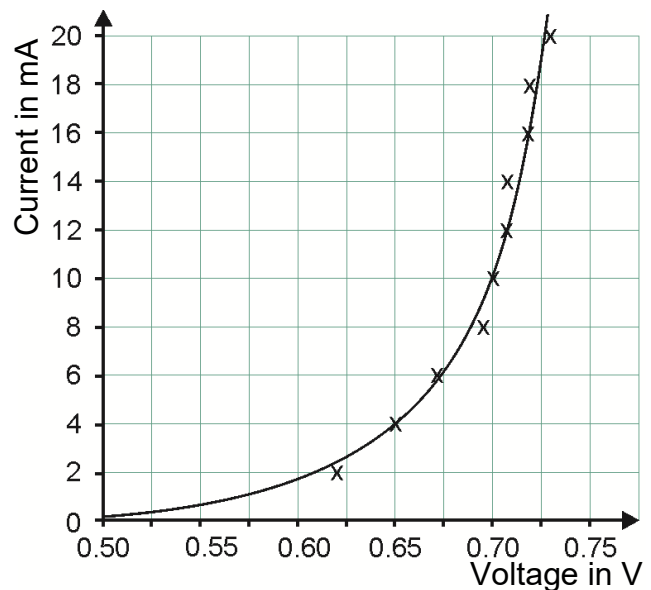

The diode is a 'one-way valve'.

It allows a current to flow through it in only one direction. (A resistor does exactly the same thing whichever way you connect it. Try it !)

When forward-biased, the diode conducts, with a voltage drop of about 0.7V across it. When reverse-biased, it does not conduct (for low voltages.)

Look underneath the 5V LED carrier. It has a resistor connected in series with it, to protect it from high currents.

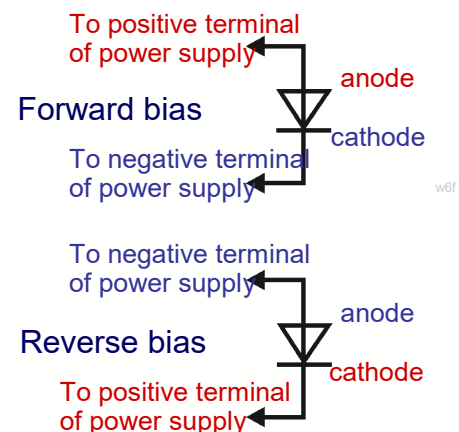

For your records:

- Copy the diagram showing the symbols for diodes and LEDs:
- The diode is a 'one-way valve'. It allows current to flow through it in only one direction, that shown by the arrow built into the symbol.
- Copy the diagram that shows the difference between forward and reverse bias.
- It conducts when it is forward-biased, and does not when reverse-biased.
- When a silicon diode conducts, there is a voltage drop of about 0.7V across it.
- The light-emitting diode (LED) behaves in a similar way. It lights up when forward biased, and the current reaches about 10mA. It then has a voltage drop of about 2V across it.
- It needs to be protected from high currents by connecting a resistor in series.

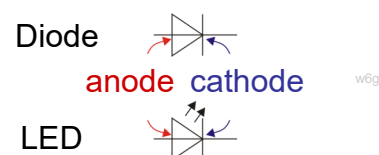

Worksheet 7

Series and parallel circuits

Electronic circuits can look complicated. However, when you look carefully, you recognise many of the component symbols.

Some components are connected so that all the current flows first through one and then through the next.

We call this a **series** connection.

Others are connected so that current divides between them.

This is a **parallel** connection. You need to be able to recognise these two types of connection and understand why they are different!

A **series** circuit offers only one route from one end of the battery back to the other!

There are no junctions in a series circuit.

A **parallel** circuit offers more than one route and so different currents flow in different parts of the circuit.

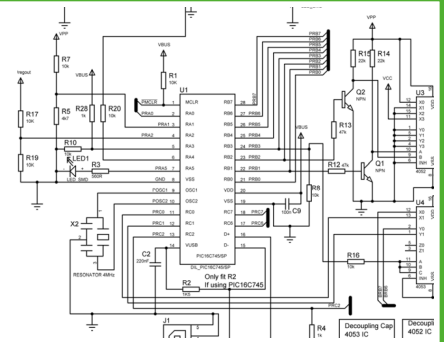

w10a

Over to you:

- Set up the arrangement shown, using 12V bulbs.
- Set the power supply to 12V DC!
- This is a series circuit - everything connected in a line, one after the other. There is only one way for current to get from one end of the power supply to the other. There are no junctions, no alternative routes!
- Does it matter where you connect the switch? Try it in different places in the circuit.
- Close the switch and notice how bright the bulbs look. Don't forget – the brighter the bulb, the greater the current flowing.
- Unscrew one of the bulbs and notice the effect. Does it matter which bulb you unscrew?
- Does it look as if electric current is getting 'used up' as it goes round the circuit? (In other words, do the bulbs get dimmer as you move further round the circuit?)
- If the bulbs have the same brightness, then the same current flows through them.
- Now change the circuit for the one shown, still using 12V bulbs.
- Make sure that the power supply is still set to 12V!
- This is **not** a series circuit — there are **two** ways to get from one end of the power supply to the other! Trace these routes out for yourself. (The 'blobs' mark junctions in the circuit.)
- Look at the brightness of the three bulbs. What does this tell us?
- Unscrew bulb A. What happens?
- Unscrew bulb B. What happens?

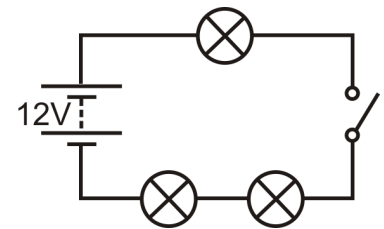

w10b

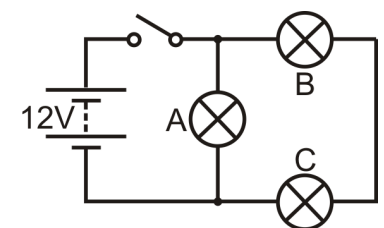

w10c

Worksheet 7

Series and parallel circuits



So what?

- In the first circuit, there is only one path for the electrons to follow from one terminal of the battery to the other. The electrons have nowhere else to go. Electrons cannot stop for a rest, don't die, don't give birth. The same current must flow everywhere!
- In the second circuit, there are two paths for the electrons to follow. One route goes through only one bulb. The other route goes through two bulbs. That route is twice as difficult for the electrons. Most take the easy route through just the one bulb. More electrons per second = bigger current. Explain to your partner or your teacher how your observations support this idea.
- The second circuit is not a series circuit as there are two ways to get from one side of the battery to the other. Bulb A is connected in parallel with the other two bulbs. Bulb B is in series with bulb C because they are on the same route.
- **A challenge!** Change the circuit so that the switch controls only bulbs B and C, **BUT** you can only move bulb A to achieve this.

For your records:

Series connections:

- A series circuit offers only one route for the electric current.
- If a break appears anywhere in the circuit, then the electric current stops everywhere.
- If one bulb fails in the circuit, then all the bulbs go out.
- The electric current is the same size throughout the circuit.

Parallel connections:

- A parallel circuit offers more than one route and so different currents can flow in different parts of the circuit.

Copy the circuit diagram and answer these questions:

1. Bulb B is in series with bulb
2. Bulb C is in with bulb E and bulb F.
3. Bulbs B and D are in with bulbs C, E and F.
4. The biggest current will flow through bulb
5. Bulb will be the brightest bulb.

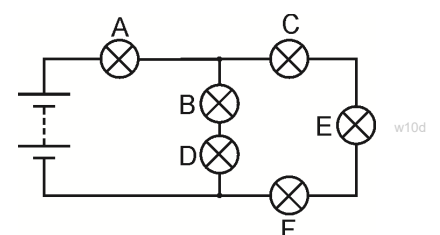

Worksheet 8

Logic gates

A logic *function* is a way to manipulate digital signals. A logic *gate* is a device that carries out a particular logic function. A *programmable logic system* can carry out a range of logic functions, depending on how it is programmed.

There are not many logic functions. This worksheet looks at the simplest, the NOT function, which could trigger a warning when a vehicle door is NOT closed, for example.



w6a

Logic gates can be built in a number of ways, leading to a number of logic 'families,' each with its own set of capabilities and limitations. One of these is called **CMOS**.

The photograph shows a CMOS NOT gate, identified by '4049'. It is known as a 'hex inverting buffer,' meaning that there are six ('hex') NOT ('inverting') gates on the chip, which buffer the signal (deliver a few milliamps of current.)



w7b

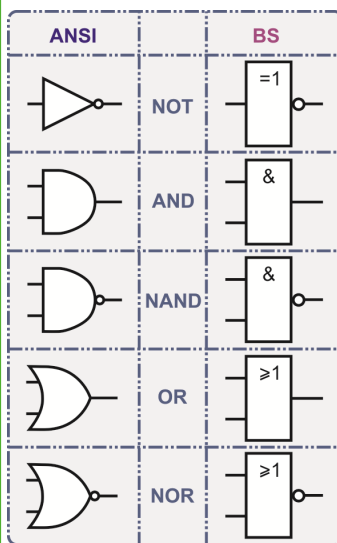

w7c

There are several versions of logic gate circuit symbols. The common ones are 'ANSI' (American National Standards Institute) and 'BS' (British Standard) sometimes called 'SB' (System Block) symbols. Both are given in the diagram opposite.

Over to you:

- Set up the circuit shown. Notice the LED connected between the output of the NOT gate and 0V, in addition to the LED built into the NOT gate carrier itself.
- Set the DC power supply to 6V.
- With the multimeter on the 20V DC range, measure the voltage at the input of the NOT gate when the switch is turned off (open.)
- Measure the output voltage of the NOT gate.
- Record both readings in the first table.
- Note whether the output LED is on or off.
- Now close the switch. Repeat and record the measurements.
- Invert the switch unit, by swapping over the switch and 10kΩ resistor.
- Repeat the measurements and record them in the second table.

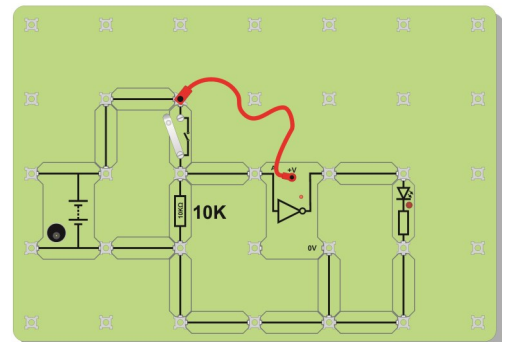

w7d

Switch	Input voltage	Output voltage	State of LED
Open (off)			
Closed (on)			

Switch (inverted)	Input voltage	Output voltage	State of LED
Open (off)			
Closed (on)			

Worksheet 8

Logic gates



So what?

First, a word about logic levels: The voltages you measured are either pretty close to +6V or 0V. For CMOS logic gates, logic 1 is any voltage greater than 70% of the supply voltage, and logic 0 anything less than 30% of supply voltage.

In this case, with a 6V power supply, logic 1 is bigger than 4.2V and logic 0 is less than 1.8V.

Use this information to convert your voltage readings into logic levels.

Then use these to complete the table, known as the **truth-table** for the NOT gate. This describes the behaviour of the gate.

The NOT gate produces the same effect, whether the switch unit is inverted or not. It turns a logic 0 input into a logic 1 output, and vice-versa.

NOT gate	
Input	Output
(Logic) 0	
(Logic) 1	

The behaviour of the switch unit has changed., however To begin with, it produced a logic 0 signal when open, and a logic 1 signal when closed. When inverted, the behaviour inverted so that with the switch open, it generated a logic 1 signal and, with it closed logic 0.

A challenge - Why do we need a resistor in the switch unit? Why not just have the switch?

See what happens when you remove the resistor from the switch unit.

With the switch between the +6V supply and the input, things seem to behave as before, when the resistor was in place. However, with the switch connected between the input and the 0V connection, nothing happens. The output of the NOT gate always sits at logic 1, regardless of the state of the switch.

CMOS circuitry is wonderful, but it has a weakness - the inputs must not 'float' (be left unconnected.) If they are, the output is unpredictable. It can even oscillate between logic 0 and logic 1, and do this so rapidly that the circuit can overheat and be destroyed.

Always use a resistor either to 'pull' the input up to logic 1, by connecting it between the positive supply and the input, or 'pull' it down to logic 0, by connecting it between the input and 0V. The 'Locktronics' NOT gate carrier is wired up so that the input sits at logic 0, when nothing is connected to it.

For your records:

- Copy the table with the symbols for the five logic gates, and then the NOT gate truth table.
- For CMOS logic gates, logic 1 is any voltage greater than 70% of the supply voltage, and logic 0 anything less than 30% of supply voltage.
- CMOS inputs must not be allowed to 'float'. Always use either a 'pull-up' or a 'pull-down' resistor. The resistance is unimportant. Anything from 1k Ω to 1M Ω will work.
- Complete the sentence:
When the NOT gate input is at logic 0, the output is at logic ..., and vice-versa.

Worksheet 9

The AND function



Often, in a car, electrical devices like the indicators, operate only when the ignition switch **AND** the switch for the device are **both** turned on.

Similarly, the headlight washers may activate only when the windscreen washers are operated **AND** the headlights are switched on.

This requires a different logic

function, the AND function.

It can be implemented using just switches, as shown in the diagram, but that can make the wiring very complicated.

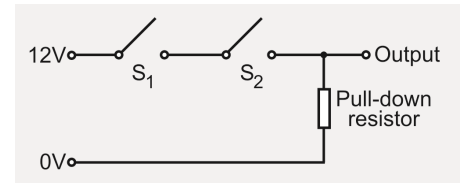

This worksheet investigates the AND function implemented using an AND logic gate.

Over to you:

- Set up the circuit shown, with the DC power supply set to 6V.
- Connect a LED carrier from the gate output to 0V.
- This time, there are four sets of measurements to make. For the first set, leave both switches open (off.)
- With the multimeter on the 20V DC range, measure the voltage at input A, and then at input B.
- Next, measure the voltage at the output of the AND gate.
- Record your measurements in the first row of the table, and note down whether the output LED is **on** or **off**.
- Now close the left-hand switch (switch 1 in the table,) leaving switch 2 open.
- Repeat the measurements, and record them in the second line of the table.
- Continue in this way to complete the table for the other combinations of switch positions.

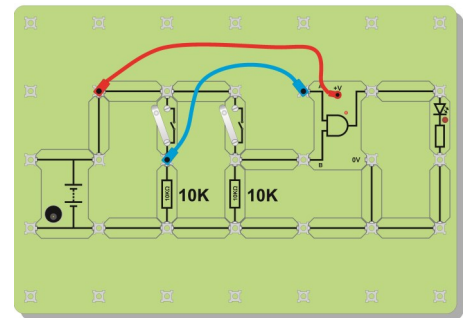

Switch 1	Switch 2	Input A voltage	Input B voltage	Output voltage	State of LED
Open (off)	Open (off)				
Open (off)	Closed (on)				
Closed (on)	Open (off)				
Closed (on)	Closed (on)				

Worksheet 9

The AND function

So what?

With a 6V power supply, logic 1 is any signal bigger than 4.2V and logic 0 less than 1.8V, as before.

Use this and your measurements to complete the truth-table for the AND gate.

The logic AND function is a straightforward one to understand. The output will be logic 1 **only** when input A **AND** input B (**AND** input C etc., if there are more inputs,) are all logic 1.

Your results should confirm this behaviour.

One way to implement the AND function is to use an AND gate. A CMOS 2-input AND gate chip is numbered 4081. The pinout for this chip is shown below.

AND gate		
Input A	Input B	Output
0	0	
0	1	
1	0	
1	1	

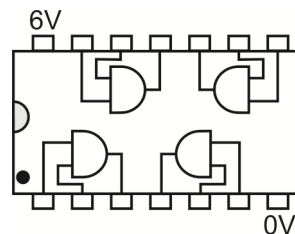

Notice that there are four AND gates on the chip.

It was pointed out earlier that CMOS logic gate inputs should not be left unconnected - should not be allowed to 'float'. When you are using a chip like the 4081, you may not want to use all four gates. In that case, connect any unused **inputs** to the nearest power rail - it does not matter which one. The unused **outputs** can, in fact must, be left alone. They will sit at the appropriate logic level depending on what signals are applied to the inputs.

For your records:

- Copy the diagram showing how the AND function can be accomplished using switches.
- Explain why the diagram can be called an AND gate.
- Copy and label the symbol for an AND gate.
- Copy the truth table for the AND gate, given opposite.
- Copy and complete the sentence:

AND gate		
Input A	Input B	Output
0	0	0
0	1	0
1	0	0
1	1	1

The output of an AND gate is at logic 1 only when

Worksheet 10

The OR function



A simple car theft-alarm system may incorporate a number of sensors:

- door sensors, to detect when the doors are opened,
- a pressure sensor, to detect changes in air pressure caused by someone breaking a window,
- a tilt sensor, to warn when the car is being towed away.

The electronic control system will switch on the alarm if a door sensor **OR** the pressure sensor **OR** the tilt sensor is triggered. This is an application of the OR logic function.

The OR function can be visualised using switches, as shown opposite.

This worksheet investigates the OR function implemented using an OR logic gate.

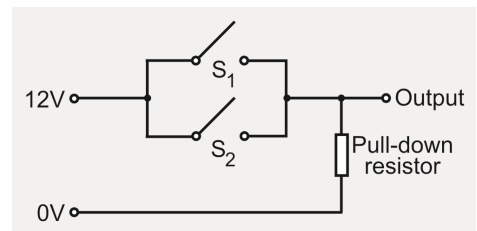

Over to you:

- Set up the circuit shown, with the DC power supply set to 6V.
- Connect a LED carrier from the gate output to 0V.
- As before, there are four sets of measurements to make. The first set has both switches open (off.)
- With the multimeter on the 20V DC range, measure the voltages at input A, at input B and at the output of the OR gate.
- Record your measurements in the first row of the table, and note down whether the output LED is on or off.
- Now close the left-hand switch (switch 1 in the table,) leaving switch 2 open.
- Repeat the measurements, and record them in the second line of the table.
- Continue in this way to complete the table for the other combinations of switch positions.

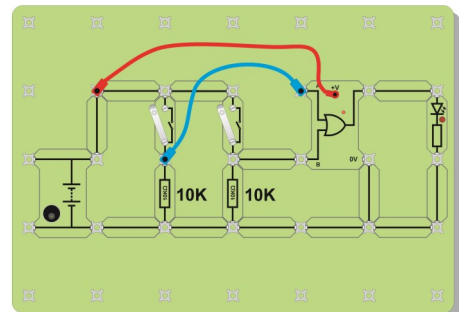

Switch 1	Switch 2	Input A voltage	Input B voltage	Output voltage	State of LED
Open (off)	Open (off)				
Open (off)	Closed (on)				
Closed (on)	Open (off)				
Closed (on)	Closed (on)				

Worksheet 10

The OR function

So what?

Once again, logic 1 is a signal bigger than 4.2V and logic 0 is less than 1.8V. Use this and your measurements to complete the truth-table for the OR gate.

The logic OR function is another straightforward one. The output of the system will be logic 1 when either input A **OR** input B (**OR** input C etc. if there are more inputs,) is logic 1 (or all of them are logic 1.) Your results should confirm this behaviour.

OR gate		
Input A	Input B	Output
0	0	
0	1	
1	0	
1	1	

One way to implement the OR function is to use an OR gate. A CMOS 2-input OR gate chip is numbered 4071. The pinout for this chip is shown below.

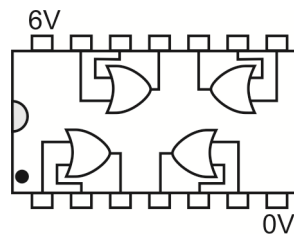

Once again, there are four gates on the chip.

As explained on the last worksheet, connect any unused *inputs* to the nearest power rail, but leave alone any unused *outputs*. They will sit at the appropriate logic level depending on the signals that are applied to the inputs. Inputs should not be allowed to 'float'

For your records:

- Copy the diagram showing how the OR function can be accomplished using switches.
- Explain why the diagram can be called an OR gate.
- Copy and label the symbol for an OR gate.
- Copy the truth table for the OR gate, given opposite.
- Copy and complete the sentence:

The output of an OR gate is at logic 1 when

OR gate		
Input A	Input B	Output
0	0	0
0	1	1
1	0	1
1	1	1

Worksheet 11

Combinational logic with NAND

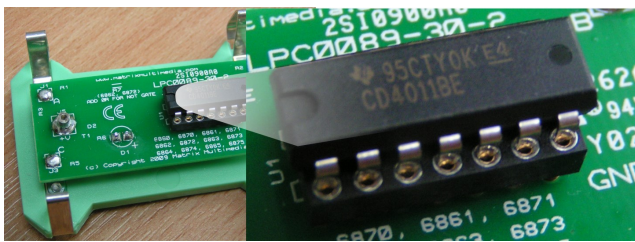

The picture shows the circuit board under the NOT gate carrier, which you used earlier.

The chip serial number may well be 4011, which is the number for a different kind of logic gate, called a NAND gate.

This worksheet examines the behaviour of this kind of gate, and shows how it can be used to provide the NOT logic function used earlier. We'll also see that the NAND logic function lends itself to applications like controlling the seat belt alarm system in an automobile.

Over to you:

- Build the circuit shown opposite.
- Set the DC power supply to 6V.
- Connect a LED from the output of the gate to 0V.
- Use the same procedure as before to complete the table with your voltage measurements, and with the state of the LED, for each switch combination.

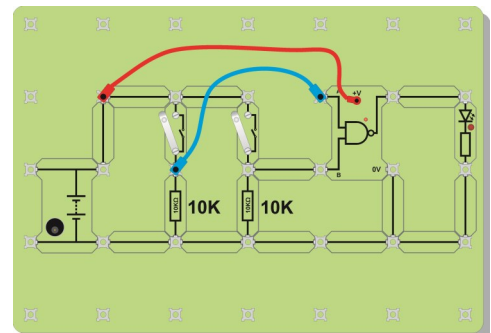

Switch 1	Switch 2	Input A voltage	Input B voltage	Output voltage	State of LED
Open (off)	Open (off)				
Open (off)	Closed (on)				
Closed (on)	Open (off)				
Closed (on)	Closed (on)				

- Re-arrange the circuit, as shown opposite, by removing one switch unit and joining the NAND gate inputs together with a connecting link.
- Turn off the remaining switch.
- Measure the voltage at the inputs of the gate and then at the output.
- Record both in the second table, together with the state of the LED.
- Then close the switch. Repeat the measurements and record them too.

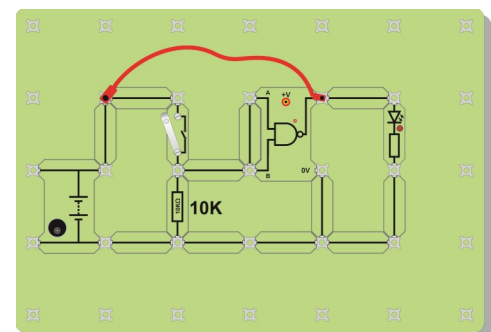

Switch	Input voltage	Output voltage	State of LED
Open (off)			
Closed (on)			

Worksheet 11

Combinational logic with NAND

So what?

- With a 6V power supply, logic 1 is a voltage greater than 4.2V, and logic 0 less than 1.8V. Use this information, and the measurements in your first results table to complete the NAND gate truth-table.

NAND gate		
Input A	Input B	Output
0	0	
0	1	
1	0	
1	1	

- A possible automotive application for the NAND logic function is the seat belt warning alarm.

Let's suppose:

- the seat belt sensor outputs a logic 1 signal when the seat belt is fastened, and a logic 0 signal when it is not;
- the alarm is triggered when it receives a logic 1 signal.

The NAND function triggers the alarm when any seat belt is unfastened.

- The second part of the investigation re-arranged the circuit so that the two inputs of the NAND gate were joined together.

One switch unit fed signals into the gate.

Compare your results with those obtained earlier.

You should find that the NAND gate now behaves like a NOT gate.

- Compare the truth-tables for the AND and NAND functions. Notice that they are opposites. When one outputs logic 1, the other outputs logic 0, and so on. As a result, the AND function can be generated by a NAND gate followed by a NOT gate.

Verify this by building and testing the circuit shown.



w17d

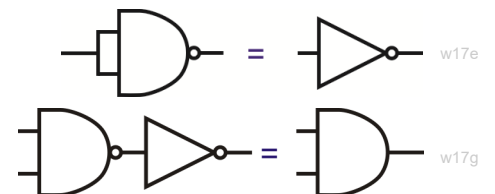

w17e

w17g

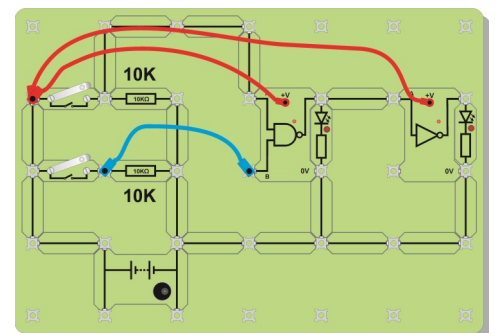

w17f

For your records:

- Copy and label the symbol for a NAND gate.
- Copy the truth table for the NAND gate given opposite.
- Copy and complete the sentence:
The output of a NAND gate is at logic 1 when any of the inputs are at logic
- Copy the diagram showing how a NOT function can be made from a NAND gate.
- Copy the diagram showing how the NAND / NOT combination generates the AND function.

NAND gate		
Input A	Input B	Output
0	0	1
0	1	1
1	0	1
1	1	0

Worksheet 11

Combinational logic with NAND

Using NAND gates to generate other logic functions

The diagram shows how NAND gates can be used to generate the other logic function:

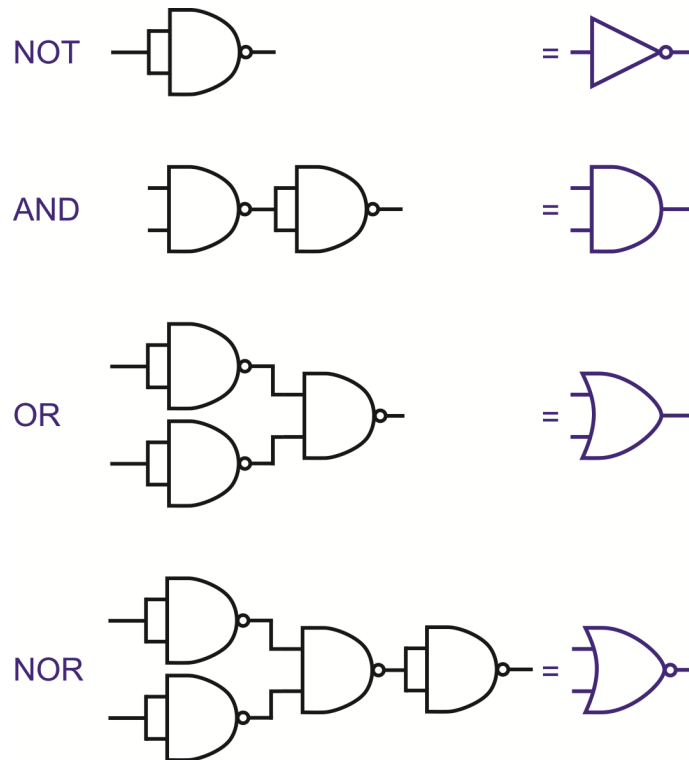

The question arises -

Why use several NAND logic gates to do the job that one discrete logic gate would do?

The answer -

Common 2-input logic gates are arranged four to a chip. If you want only one, you still use one chip. Using NAND gates is still a one chip solution, even to generate the NOR function. It might even work out cheaper if it means that you can bulk-buy just the one type of chip.

(In cases where several logic functions are combined together, it may be possible to cancel out adjacent NOT functions, resulting in even greater savings. This is known as gate minimisation, but this is beyond the scope of the present course.)

Worksheet 12

Combinational logic with NOR

The NOR function may be the last we study, but it is by no means the least important. Perhaps this is why the CMOS series starts with the serial number 4000, a 3-input NOR gate chip, and then the 4001, a 2-input NOR gate!

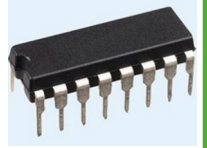

w18a

As with the NAND function, NOR gates can be combined together to generate any other logic function. The diagrams show how this is done.

Doing so can result in cost savings, because of gate minimisation techniques, which are beyond the scope of this course, or through the economy of scale of bulk-buying.

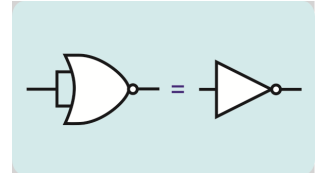

w18b

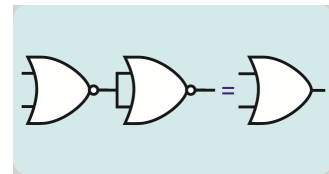
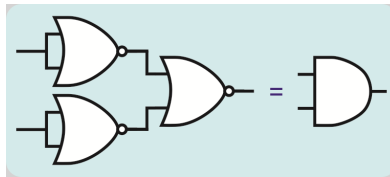
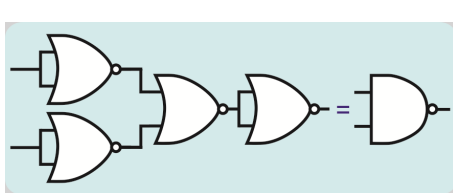

w18c

w18d

w18e

Over to you:

- Build the circuit shown opposite.
- Set the DC power supply to 6V.
- Connect a LED from the output of the gate to 0V.
- As before, there are four sets of measurements to make. The first set has both switches open (off.)
- With the multimeter on the 20V DC range, measure the voltages at inputs A and B and at the output of the gate.
- Record the measurements you have just taken, in the first row of the table and include the state (on / off) of the LED.
- Complete the table using the same procedure as in the last worksheet.

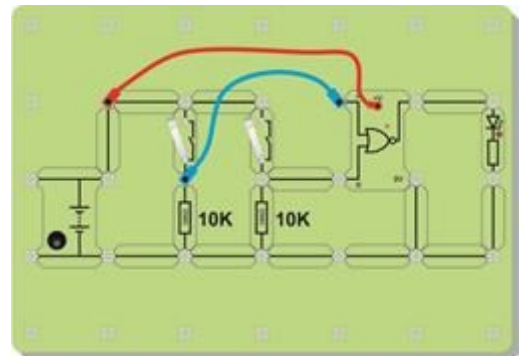

w18f

Switch 1	Switch 2	Input A voltage	Input B voltage	Output voltage	State of LED
Open (off)	Open (off)				
Open (off)	Closed (on)				
Closed (on)	Open (off)				
Closed (on)	Closed (on)				

Worksheet 12

Combinational logic with NOR

So what?

As before, logic 1 is a voltage greater than 4.2V and logic 0 is less than 1.8V.

Use this information, and your measurements to complete the truth-table for the NOR gate.

NOR gate		
Input A	Input B	Output
0	0	
0	1	
1	0	
1	1	

A possible automotive application for the NOR logic function is the air-conditioning system. There is no point in trying to cool down the cabin of the vehicle if a door is open.

Let's suppose that:

- there are two doors;
- the door sensors output a logic 1 signal when the door is open, and logic 0 when it is closed;
- the air-conditioning turns off when it receives a logic 0 signal from the door logic system.

The NOR function allows the air-conditioning to run only when both doors are closed.



w18g

Compare the truth-tables for the OR and NOR functions. Notice that they are opposites. When one outputs logic 1, the other outputs logic 0, and so on. This means that the OR function is equivalent to a NOR gate followed by a NOT gate. This is shown in the diagram opposite:

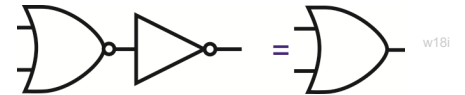

w18i

Verify this by building and testing the circuit shown.

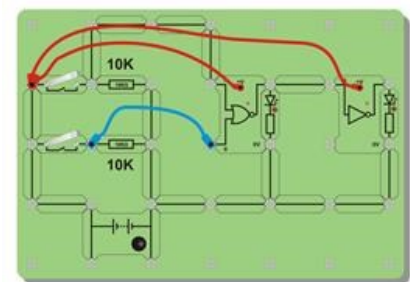

w18h

For your records:

- Copy and label the symbol for an NOR gate.
- Copy the truth table for the NOR gate, given opposite.
- Copy and complete the sentence:
The output of a NOR gate is at logic 0 only when
- Copy the diagram showing how the NOR / NOT combination generates the OR function.

NOR gate		
Input A	Input B	Output
0	0	1
0	1	0
1	0	0
1	1	0

Worksheet 13

Testing transistors

Originally called a ‘transfer resistor’, the transistor is found in almost every electronic circuit, either as a discrete component or within an integrated circuit (IC). ICs contain many hundreds, thousands or even millions of transistors.

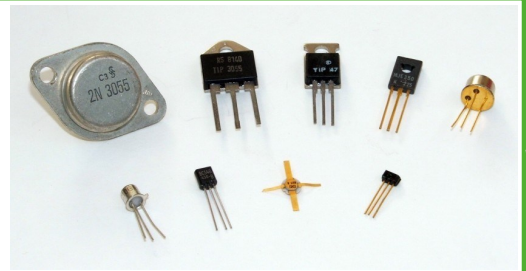

Bipolar junction transistors (BJT) come in two types, NPN or PNP, depending on the impurities used to ‘dope’ the single crystal of silicon it is made from. The resulting PN junctions are manufactured by diffusing impurities through a photographically reduced mask.

In this worksheet you will learn how to carry out basic checks on NPN and PNP transistors.

Over to you:

- Build the circuit shown in the upper diagram, to allow you to test an NPN transistor.
- Set the DC power supply to output 6V.
- Set the multimeter to read up to 20mA DC.
- Measure the current flowing. Record it in the first table.
- Press and hold the switch closed.
- Measure and record the new current.
- Next, build the lower circuit, designed to test a PNP transistor. Notice that the power supply and multimeter are now inverted.
- Repeat the same procedure as for the NPN transistor.
- Record the measurements in the second table .

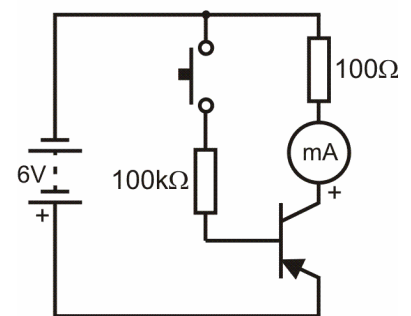
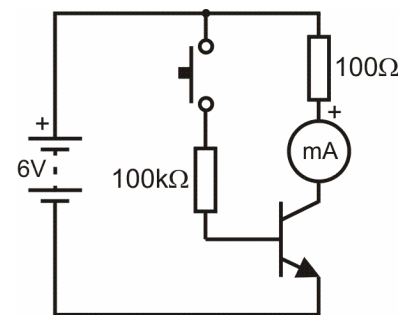

NPN Transistor	
Switch	Collector current (mA)
Open ($I_B = 0 \mu\text{A}$)	
Closed ($I_B \sim 54 \mu\text{A}$.)	

PNP Transistor	
Switch	Collector current (mA)
Open ($I_B = 0 \mu\text{A}$)	
Closed ($I_B \sim 54 \mu\text{A}$.)	

Worksheet 13

Testing transistors

So what?

- What do the results tell you? Are the devices that you have checked functional? If not, what faults did you detect?
- The ratio of collector current (I_C) to base current (I_B) for a transistor gives the value of current gain, called h_{FE} , for the device.
In other words,

$$h_{FE} = I_C / I_B$$

Calculate the current gain for each of the devices that you have checked.

- Transistors are mass-produced. The manufacturer will quote typical values for the current gain, but two individual devices may differ widely. Given that the current gain for a small-signal transistor can vary from about 75 to 250, are your calculated values of current gain typical?

The diagrams show the direction of current flow in both NPN and PNP transistors. Study them carefully.

You can see why the PNP transistor can be considered as a mirror-image of the NPN device.

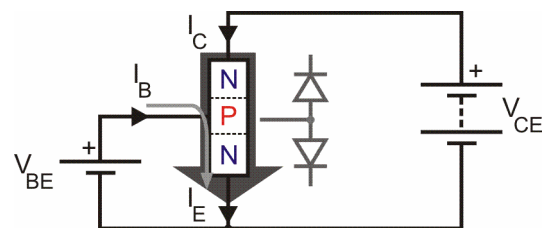

w11c

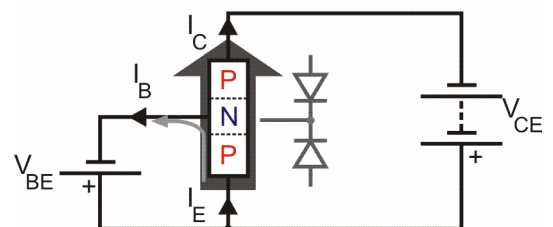

For your records:

It is often useful to be able to perform a quick functional check on a transistor.

- This can be done easily if a multimeter with a transistor-check facility is available.
- Alternatively, the forward and reverse resistance of each of the two diode junctions within the transistor can be measured using a multimeter on the ohmmeter range.
- A third approach is to connect a transistor to a power supply and measure the current flowing in the collector in response to a current applied to the base. A large current should flow in the collector when a much smaller current is applied to the base. This is the approach you used in this investigation.

Worksheet 14

Transistor as a switch

Mechanical switches operate at very low speeds. Transistors, electronic switches, can switch current many millions of times faster. There are no mechanical moving parts and so no friction and no wear-and-tear.

Transistor switches operate under **saturated** conditions, meaning that the collector voltage will be either the same as the supply voltage (in the 'off' state) or very close to 0V (in the 'on' state).

In this worksheet, you build two simple switching circuits. The first operates a LED, the second a DC motor.

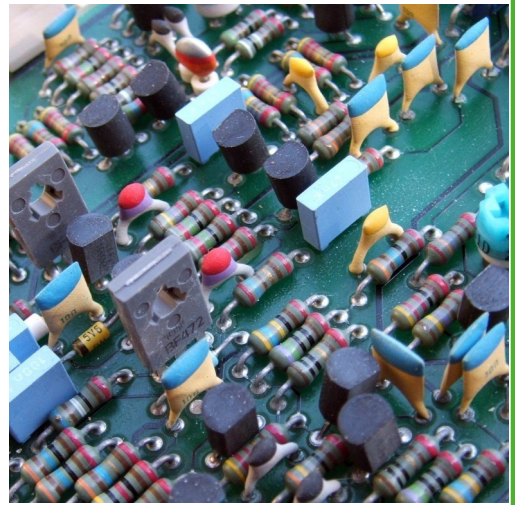

Over to you:

- Build the first switching circuit. The LED is controlled by the switch. The small base current that flows when the switch is closed produces a much larger collector current, flowing through the LED.
- Measure and record the voltages V_L across the LED, and V_{CE} , across the transistor,

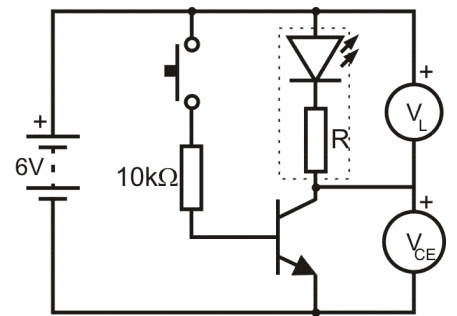

Switch	V_{CE}	V_L
Off		
On		

- Build the second switching circuit., which includes a 1N4001 power diode, for reasons given on the next page. The switch now controls a motor. As before, the small base current that flows when the switch is closed controls a much larger collector current, flowing through the motor.
- Measure and record the voltages V_L , across the motor, and V_{CE} , across the transistor.

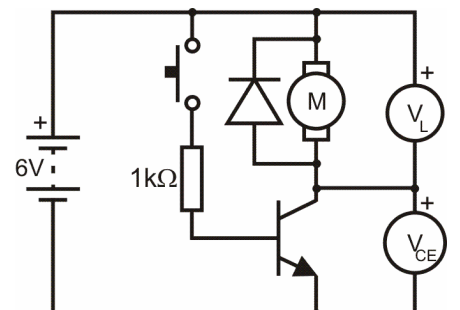

Switch	V_{CE}	V_L
Off		
On		

Worksheet 14

Transistor as a switch



So what?

A diode is included across the load in the motor circuit, but not in the LED circuit.

Here's why:

- The motor is an electromagnetic device. It rotates because a strong magnetic field is created in its coil when a current flows through it.
- When the current ceases to flow, that magnetic field collapses through that coil of wire, and generates a large voltage in the opposite direction - an example of Lenz's law.
- This 'back emf' can be big enough to damage the transistor.
- To avoid this, a diode is connected in reverse parallel. As far as the power supply for the circuit is concerned, the diode is reverse-biased and essentially does nothing. For the large voltage generated by the falling current, however, the diode is forward-biased, and so conducts freely. The voltage drop across it is clamped to 0.7V, or -0.7V as seen by the transistor. This causes no damage to the transistor.
- Any similar electromagnetic device, such as a relay, should be bypassed by a reverse parallel diode in this way, for the same reason.

Look at the two results tables for V_{CE} and V_L :

- Add together the measurements, V_{CE} and V_L in each case. What do you notice?
- What do you expect the result to be, bearing in mind that the transistor and the LED / motor form a voltage divider across the power supply rails?

Challenge! Modify the LED circuit so that the LED remains **on** when the switch is open and goes **off** when it is closed. (Hint: You will have to change the position of the switch in the circuit).

Challenge! Modify the motor circuit so that the switch controls both a LED and the motor.

For your records:

- Is the transistor operating as a saturated switch in both circuits?
How do you know?
- Explain why the base resistor has a much lower value in the motor circuit than for the LED.
- Calculate the base current that flows when the switch is closed in:
 - the LED circuit;
 - the motor circuit.

(Assume that the base-emitter voltage is 0.7V when the transistor is conducting.)

Worksheet 15

Transistor as an amplifier

When a bipolar junction transistor is used to amplify audio signals, we first ensure that the transistor is **biased**, meaning that some collector current will flow even when no signal is present.

In this worksheet you will investigate the operation of a very simple common-emitter amplifier stage that uses this technique.

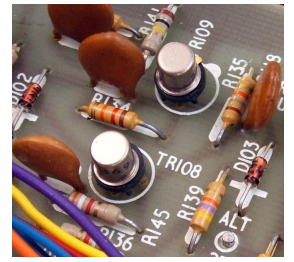

Over to you:

- Build the circuit shown, using a 10kΩ load resistor.
- Set the DC power supply to 6V.
- Measure and record the DC voltages present at the collector, base and emitter of the transistor.
- Connect the input to a signal generator, set to output a 50mV peak-to-peak sine wave at a frequency of 1kHz.
- Connect a dual-trace oscilloscope to display the input and output waveforms. Connect the ground terminal to the negative supply rail.
- Adjust the oscilloscope controls to display two cycles of the input and output waveforms.
- Sketch these on grids like those below. Measure the peak-to-peak input and output voltages.
- Increase the input voltage to 100mV pk-pk. Observe and sketch the effect on the output.

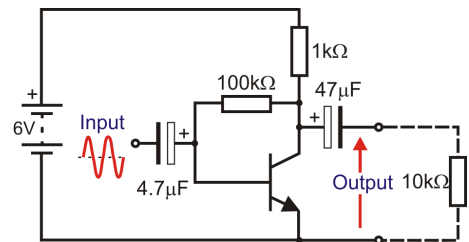

Measurement	Voltage
DC bias voltage at collector	
DC bias voltage at base	
DC bias voltage at emitter	
Input voltage, pk - pk	
Output voltage, pk - pk	

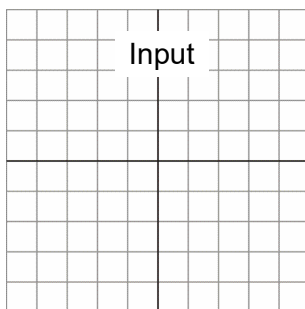

Input = 50mV pk-pk

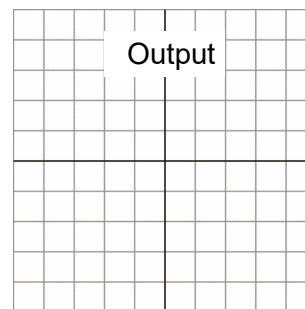
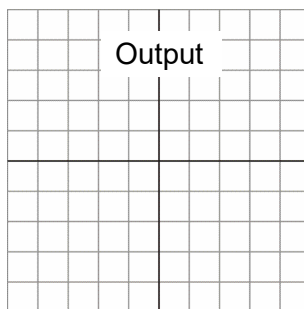

Input = 100mV pk-pk

Typical oscilloscope settings:

Timebase	100μs/div (X multiplier x1)	
Voltage range	Input A - ±100mV DC (Y multiplier x1)	Input B - ±10V DC (Y multiplier x1)
Trigger Mode	Auto	Trigger Channel - Ch.A
Trigger Direction	Rising	Trigger Threshold - 10mV

Worksheet 15

Transistor as an amplifier



So what?

The way the transistor behaves:

When the input voltage **increases**:

- the base current **increases**;
- the collector current **increases**;
- the voltage across the $1\text{k}\Omega$ resistor **increases**;
- the output voltage **decreases**.

When the input voltage **decreases**:

- the base current **decreases**;
- the collector current **decreases**;
- the voltage across the $1\text{k}\Omega$ resistor **decreases**;
- the output voltage **increases**.

For this to happen, we allow some base current to flow all the time, even when no input signal is present. This is called DC biasing. When no signal is present, a small base current can still flow through the $1\text{k}\Omega$ and $100\text{k}\Omega$ resistors.

As a result, a bigger collector current flows, creating a voltage drop across the $1\text{k}\Omega$ resistor, and leaving an output voltage less than the supply voltage. The greater the base current, the greater the collector current, the greater the voltage drop across the $1\text{k}\Omega$ resistor, and the lower the output voltage across the collector-emitter junction.

We aim to make the output voltage roughly equal to half of the supply voltage when no signal is present, which is called the quiescent state. As a result, when a signal is present, the output voltage can rise and fall by very similar amounts .

The signal is connected to the input and output of the amplifier via capacitors, called DC blocking capacitors. They isolate the amplifier so that the DC voltages and currents inside it are unaffected by whatever is connected to the input and output terminals.

- Use your results (input voltage and output voltage,) to calculate the voltage gain of the amplifier:

Voltage gain =

For your records:

- Explain why the output becomes distorted for larger input signal amplitudes.
- What is the maximum output signal voltage before distortion is noticeable?
- How could the output voltage be increased?

Worksheet 16

Non-inverting amplifier

w14a



Audio systems need careful design. It's not enough to design each stage as a separate system. Each stage must 'talk' effectively to the next, i.e. must transfer its signal without loss or distortion.

The op-amp has a number of roles in this. Designed properly, the non-inverting amplifier draws very little current from the input subsystem that supplies it with an audio signal, an important element of the design.

Over to you:

- The next investigation uses the circuit shown opposite. Build this, using a value of $1k\Omega$ for R_F and $1k\Omega$ for R_1 . One way to do so is shown in the picture below.
- Use a digital multimeter set on the 20V DC range to measure the voltage V_{IN} .
- Turn the 'pot' to set this voltage to +2.5V.
- Measure the output voltage V_{OUT} and record its value in the first row of the left-hand table.
- Repeat this process for all the other values of V_{IN} .
- Calculate the gain using the formula:

$$\text{Voltage gain} = V_{OUT} / V_{IN}$$
 Use your results to complete the third column.
- Now swap the $1k\Omega$ feedback resistor for a $10k\Omega$ resistor.
- Repeat the process, using the new values of V_{IN} given in the right-hand table.
- Complete the table in the same way as before.

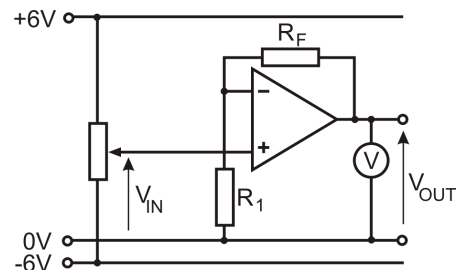

w14b

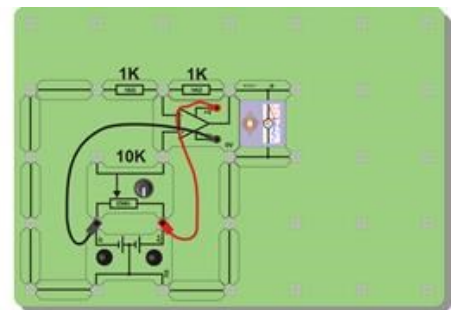

w14c

$R_F = 1k\Omega, R_1 = 1k\Omega$		
V_{IN}	V_{OUT}	Gain
+2.5V		
+1.5V		
+0.5V		
-0.5V		
-1.5V		
-2.5V		

$R_F = 10k\Omega, R_1 = 1k\Omega$		
V_{IN}	V_{OUT}	Gain
+0.5V		
+0.3V		
+0.1V		
-0.1V		
-0.3V		
-0.5V		

Worksheet 16

Non-inverting amplifier



So what?

The industry standard op-amp is the '741', produced by Fairchild Semiconductors in 1968. Since then, many improvements have been made to the performance.

The ideal characteristics of an op-amp are:

- infinite open-loop voltage gain;
- infinite bandwidth, (the range of frequencies amplified successfully;)
- infinite input impedance, (draws no current from the device creating its input signal;)
- infinite slew-rate, (the output voltage can leap instantly to any value;)
- zero output impedance, (delivers the full output voltage to any subsystem that follows;)
- infinite common-mode rejection ratio (CMRR) (amplifies only the difference in voltage between the inputs and ignores any voltage common to both, such as interference.)

Often, subsystems delivering a signal to an amplifier, such as a microphone, cannot provide much current. If the amplifier draws significant current from it, then the signal voltage falls, defeating the point of using an amplifier. The non-inverting amplifier, however, offers a very high input impedance, typically $1\text{M}\Omega$, so that it draws very little current from its signal source.

The theoretical value for the voltage gain is given by the formula:

$$\text{Voltage gain} = 1 + R_F / R_1$$

For the first part of the investigation, where $R_F = 1\text{k}\Omega$ and $R_1 = 1\text{k}\Omega$, this gives a value:

$$\text{Voltage gain} = 1 + 1 / 1 = 2$$

(Using any two equal valued resistors would give the same voltage gain. Using high values reduces battery drain and power dissipation.)

For the second part, where $R_F = 10\text{k}\Omega$ and $R_1 = 1\text{k}\Omega$, this gives a value:

$$\text{Voltage gain} = 1 + 10 / 1 = 11.$$

Look at your measurements. Do they support these values of voltage gain?

For your records:

- Draw the circuit diagram for the non-inverting voltage amplifier.
- Write down the formula linking voltage gain to input voltage and output voltage.
- Write down the formula linking the voltage gain of a non-inverting amplifier to the values of the feedback resistor and resistor R_1 .
- Copy the following table and complete it:

Input voltage	Output voltage	Voltage gain	Resistor R_F	Resistor R_1
5mV			22k Ω	2k Ω
	300mV	15		1k Ω
20mV	400mV		38k Ω	
10mV		10		10k Ω
3mV	18mV		100k Ω	

Worksheet 17

Inverting amplifier



The inverting amplifier is somewhat inferior as a voltage amplifier, because it usually draws more current from its signal source, than does the non-inverting amplifier.

However, a number of exciting applications are based on this circuit.

The fact that it inverts the signal is not significant - an audio signal sounds just the same whether or not it is inverted!

Over to you:

- The next investigation uses the circuit shown opposite. Build it, using a value of $10\text{k}\Omega$ for R_F and $10\text{k}\Omega$ for R_{IN} . The picture shows one way to do this.
- Use a digital multimeter to monitor the input voltage V_{IN} . Turn the 'pot' to set this to $+2.5\text{V}$.
- Measure the output voltage V_{OUT} and record it in the first row of the left-hand table.
- Repeat this process for all the other values of V_{IN} .
- Calculate the voltage gain using the formula:

$$\text{Voltage gain} = V_{OUT} / V_{IN}$$
 and hence complete the third column.
- Now swap the $10\text{k}\Omega$ input resistor for a $1\text{k}\Omega$ resistor.
- Repeat the same process, using the values of V_{IN} given in the right-hand table.
- Complete this table in the same way as before.

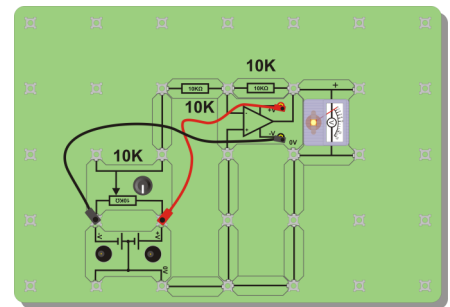
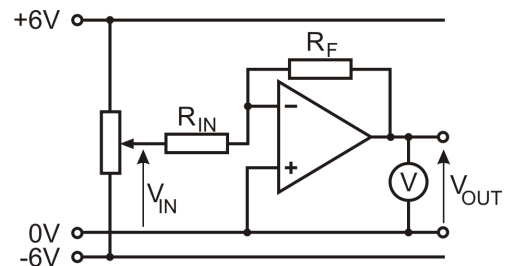

$R_F = 10\text{k}\Omega, R_{IN} = 10\text{k}\Omega$		
V_{IN}	V_{OUT}	Gain
+2.5V		
+1.5V		
+0.5V		
-0.5V		
-1.5V		
-2.5V		

$R_F = 10\text{k}\Omega, R_{IN} = 1\text{k}\Omega$		
V_{IN}	V_{OUT}	Gain
+0.5V		
+0.3V		
+0.1V		
-0.1V		
-0.3V		
-0.5V		

A challenge:

- How could you use a $10\text{k}\Omega$ resistor and two $1\text{k}\Omega$ resistors to give you a voltage gain of 5? Test your idea by modifying the circuit you used above.

Worksheet 17

Inverting amplifier

So what?

An important observation in any op-amp circuit where the output is not saturated:

$$V_2 = V_1$$

The reason:

- the output voltage is never very large, say 10V maximum;
- $V_{OUT} = A_0 \times (V_2 - V_1)$, provided that the output is not saturated;
- open loop gain, A_0 , is around 100,000;
- hence, $10 = 100,000 \times (V_2 - V_1)$, so $(V_2 - V_1) \sim 0.0001V$,
or, to a good approximation: $V_2 = V_1$

In the case of the inverting amplifier, $V_2 = 0V$, because it is connected directly to it.

As long as the output is not saturated then, $V_1 = 0V$ also. This can be a good experimental check that the op-amp is working correctly.

For the inverting amplifier:

$$\text{Voltage gain} = -R_F / R_{IN}$$

As a result:

- when $R_F = R_{IN}$, the voltage gain = -1;
- when $R_F = 10 \times R_{IN}$, the voltage gain = -10, and so on.

Since $V_1 = 0V$ when the output is not saturated, (and amplifiers should never be driven into saturation,) the input source sees the amplifier as having a resistance of R_{IN} :

The value of R_{IN} should be kept large in order to limit the current that the amplifier draws from the input source. It should be at least $1k\Omega$, and preferably bigger than $10k\Omega$.

For your records:

- Draw the circuit diagram for the inverting voltage amplifier.
- Write down the formula linking the voltage gain of an inverting amplifier to the values of the feedback resistor and input resistor.
- Copy the following table and complete it:

Input voltage	Output voltage	Voltage gain	Resistor R_F	Resistor R_{IN}
5mV			20k Ω	2k Ω
	-300mV	12		10k Ω
20mV	100mV		100k Ω	
-10mV		3		10k Ω
3mV	-24mV		240k Ω	

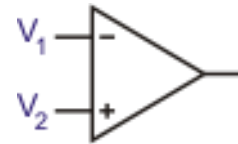

w15d

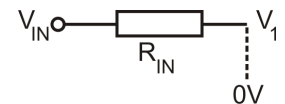

w15e

Worksheet 18

Timers

The 555 timer, a neat mixture of analogue and digital circuitry, is a very versatile chip, found in a wide variety of electronic circuits. It can operate in a monostable circuit, producing a single pulse of precise duration, and also in an astable circuit, producing a continuous train of pulses with a precise frequency and duty cycle. The 555 timer is supplied in an 8-pin dual-in-line package and it operates from supply voltages over the range 4.5V to 15V.

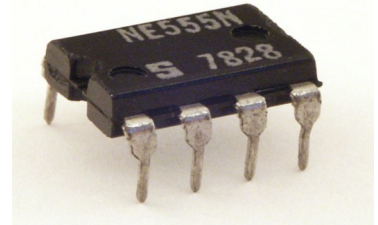

Over to you:

Monostable timer:

- Build the monostable circuit shown opposite, using values of $R = 100\text{k}\Omega$ and $C = 4.7\mu\text{F}$.
- The LED connected to the output gives a visual display of the output state. It is on when the output is 'high' ($\sim 5\text{V}$) and off when the output is 'low' ($\sim 0\text{V}$).
- Use an oscilloscope to display the output waveform. (Typical settings are given below.)
- Press and then release trigger switch, S.
- At the same time observe the pulse on the oscilloscope. Measure the pulse duration, t , and record it in a table like the one below.
- Repeat this process for other combinations of C and R.
- Use your results to verify the relationship $t = 1.1 CR$.

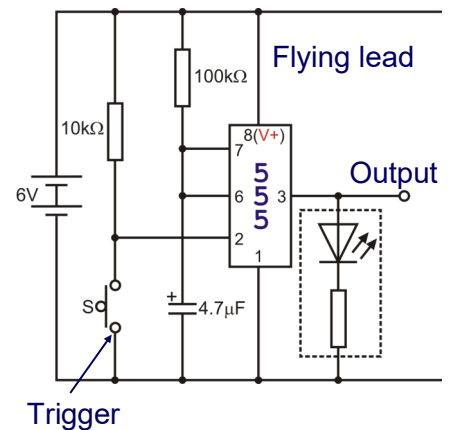

Resistor R in $\text{k}\Omega$	Capacitor C in μF	Pulse duration t in ms
100	4.7	

Typical oscilloscope settings:

Timebase	100ms/div (X multiplier x1)	
Voltage range	Input A - $\pm 10\text{V}$ DC (Y multiplier x1) Input B - off	
Trigger Mode	Auto	Trigger Channel - Ch.A
Trigger Direction	Rising	Trigger Threshold - 10mV

Worksheet 18

Timers

Over to you:

Astable timer:

- Build the astable circuit shown opposite.
- The LED again displays the output state. If the output is changing rapidly, the LED will appear to be on, but dimmer. In reality, it is flashing very fast.
- Use an oscilloscope to display the output waveform. (Typical settings are given below.)
- With $R = 100\text{k}\Omega$ and $C = 4.7\mu\text{F}$, observe the output pulse train. (If the circuit fails to 'start', disconnect and reconnect the flying lead.)

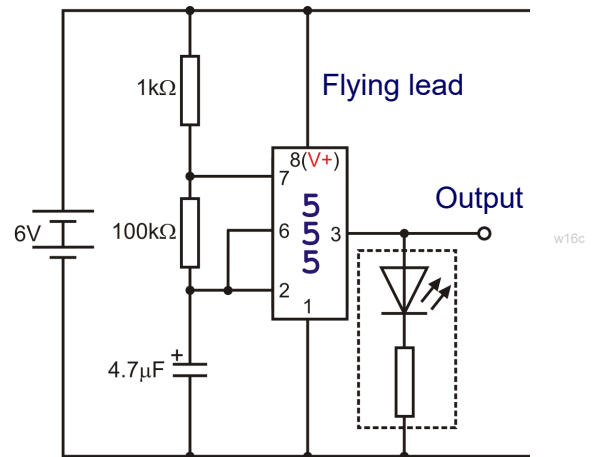

- Use the oscilloscope to measure the 'high' (t_{high}) and 'low' (t_{low}) pulse times. Add these together to give the signal period (t).
- Record your results in a table like that opposite.
- Repeat for other combinations of C and R.
- Use your results to verify the following:

$$t_{\text{high}} = 0.693(R + 1000) \times C,$$

$$t_{\text{low}} = 0.693RC,$$

and $t = t_{\text{high}} + t_{\text{low}} = 0.693(1000 + 2R)C$

R in k Ω	C in μ F	t_{high} in ms	t_{low} in ms	t in ms
100	4.7			

Typical oscilloscope settings:

Timebase	100ms/div (X multiplier x1)	
Voltage range	Input A - $\pm 10\text{V DC}$ (Y multiplier x1)	
	Input B - off	
Trigger Mode	Auto	Trigger Channel - Ch.A
Trigger Direction	Rising	Trigger Threshold - 10mV

For your records:

- Design a time delay circuit that will produce an output of exactly 1s duration.
- Design an astable oscillator that will produce a square wave with a frequency of 1kHz.
- Explain why the astable oscillator can never produce a perfect square wave output.

Worksheet 19

Simple radio transmitter

Radio communication allows us to send voice, music and data signals without any wired connections. To do so, we modulate the signal onto a high frequency carrier wave, using techniques such as AM (amplitude modulation) and FM (frequency modulation).

In this investigation you build a simple low-power AM transmitter. You receive the transmission on an ordinary domestic radio receiver tuned to the long wave (LF) band!



w19a

Over to you (optional investigation):

- Build the circuit shown opposite. TR2 generates the carrier wave and a signal applied to the modulation input causes TR1 to modulate it.
- Set the DC power supply to 9V.
- Connect an oscilloscope to the output.
- Connect a short length of wire to the output to act as an antenna.
- Place this close to an AM radio receiver, tuned to around 250 kHz on the long wave (LF) band.
- Slide the ferrite core in T1 in and out to 'tune' the transmitter, until the unmodulated carrier wave is heard as a strong 'blank' signal. (Adjusting the core typically produces a frequency change from about 125 kHz (fully inserted) to 250 kHz (almost fully removed)).
- Observe the unmodulated waveform on the oscilloscope. Sketch at least two cycles of it.
- Measure and record the peak-peak voltage and period of the RF output. Hence calculate the output frequency.
- Now connect an audio frequency (AF) signal generator, set to produce an output of 1V peak-peak at 1kHz to the modulation input.
- Observe the output waveform on the oscilloscope and sketch at least two cycles.
- Listen to the signal on the radio receiver and check that a 1kHz tone is heard.
- Finally, disconnect the signal generator and replace it with a dynamic microphone. You should then be able to transmit voice signals over a short distance!

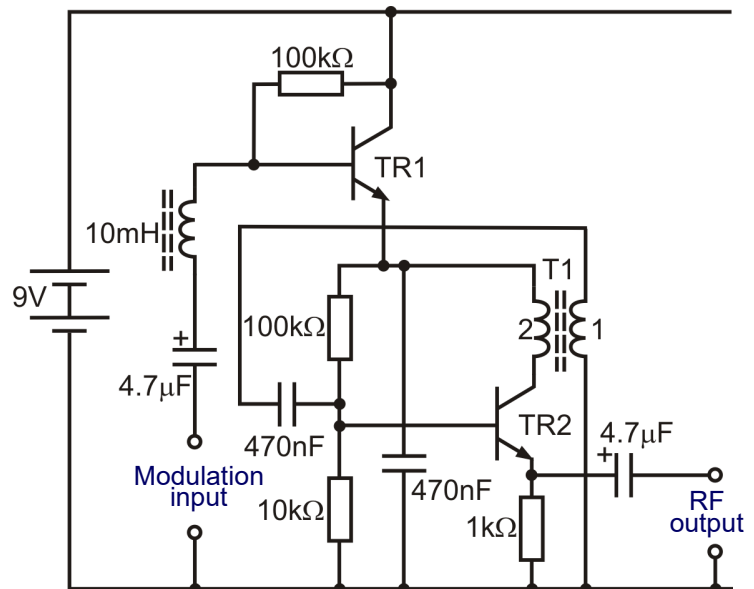

w19b

Worksheet 19

Simple radio transmitter

Over to you:

- The diagram opposite shows one way to assemble the circuit on a baseboard.
- This simple RF oscillator produces a large number of harmonics.
Try to find these harmonics by tuning the radio receiver over the medium wave (MF) band.
How many harmonics can you detect and on what frequencies do they occur?

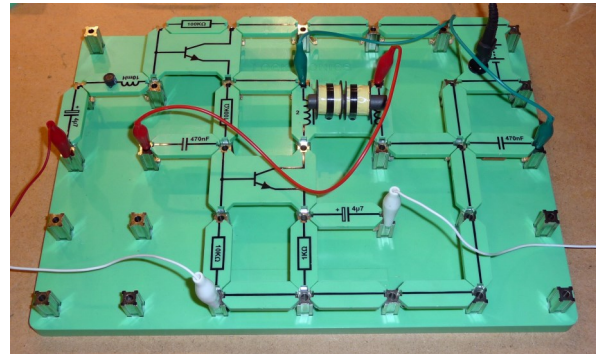

• Glossary of radio vocabulary:

- **Signal** - the message, or information that you want to transfer. (See graphs **A** and **D**).
- **Carrier** - the means of transmitting the signal from one point to another;
- a wave of constant amplitude and constant frequency. (See graphs **B** and **E**).
- **Modulation** - modify or adjust one characteristic by means of another.
- **Amplitude modulation** - as the signal amplitude increases, so does the amplitude of the carrier. See graph **C**.
- **Frequency modulation** - as the signal amplitude increases, so does the frequency of the carrier. See graph **F**.

(Other forms of modulation are available!)

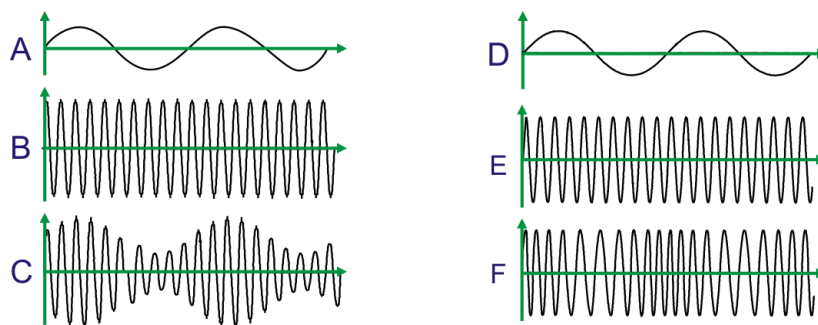

For your records:

Write short descriptions for the following terms, using diagrams to make your ideas clearer:

- amplitude modulation;
- frequency modulation.
- What determines the frequency at which the transmitter operates? How could you change this so that the transmitter operates on the medium wave (MF) band?
- The RF oscillator that generates the carrier wave uses closed-loop positive feedback. Explain how this feedback is applied.

Worksheet 20

Simple radio receiver

Communication systems require both a transmitter and a receiver. In this final this worksheet you construct and test a simple AM radio receiver.

The receiver covers the long-wave (LF) band and tunes from about 135 kHz to 280 kHz. The output waveform from the receiver can be displayed on an oscilloscope or monitored with an ordinary pair of headphones.

For good reception you will need to use a wire aerial (or 'antenna') of 10 to 20 m in length!



w20a

Over to you (optional investigation):

- Build the receiver circuit shown opposite. The receiver uses three stages:
 - a tuned circuit (using the transformer T1 and 100 pF capacitor),
 - a diode demodulator (D1)
 - a high-gain audio amplifier (IC1).

When a modulated RF signal is connected to the input, the audio signal will appear at the output.

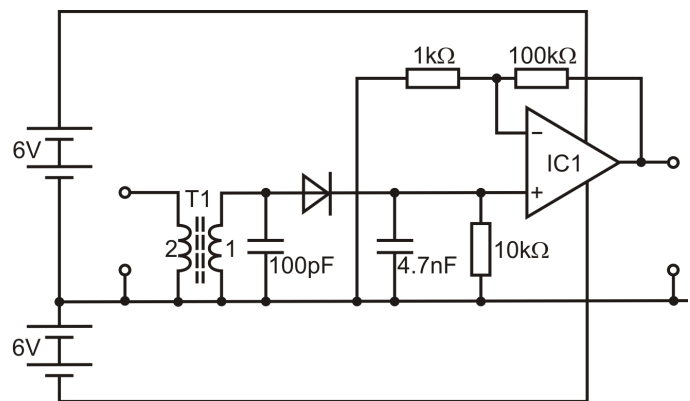

w20b

- Set both DC power supplies to 6V, and connect the positive and negative supplies to the operational amplifier using flying leads.
- With the modulation switched on, connect an oscilloscope to the output in order to display the output waveform (if a dual-beam oscilloscope is available you will be able to display the input and output waveforms simultaneously—see next page).
- Vary the frequency of the signal generator over the range 130 kHz to 280 kHz and observe the effect of changing the position of the ferrite core on the receiver's tuning.
- With the modulation switched off, tune the receiver to a frequency of around 170 kHz and measure the DC output voltage using a voltmeter. Vary the output frequency of the signal generator in suitable steps and make a table of output voltage readings against frequency.
- Use this data to plot a selectivity curve (output voltage plotted against frequency) for the receiver - see details on the next page.
- Finally, disconnect the signal generator and connect a length of wire (at least 10 m) to the input of the receiver. Connect a pair of headphones to the output and tune the receiver until one or more signals are heard in the long-wave band.

Worksheet 20

Simple radio receiver

Over to you:

- The output (upper trace in red) and input (lower trace in blue) waveforms are shown in the picture above. Did your waveforms look like this?
- In the waveforms shown, the modulation depth is about 50%. Try varying the depth of modulation and noting what effect it has on the waveform. What would happen if the modulation depth was to exceed 100%?
- What determines the frequency at which the receiver operates? How could you change it so that the transmitter operates on the medium wave (MF) band?
- The receiver can be made more sensitive by increasing the voltage gain of the operational amplifier. Try replacing the 1k Ω resistor by a resistor of 100 Ω . This will increase the voltage gain a further ten times.
- The receiver is not very selective. What effect does this have when receiving strong broadcast signals? Explain why this is. How could you improve the receiver's selectivity?
- The receiver is tuned by varying the position of the ferrite core. In practice this isn't a very convenient way of tuning a radio receiver. Suggest a better way to do this.

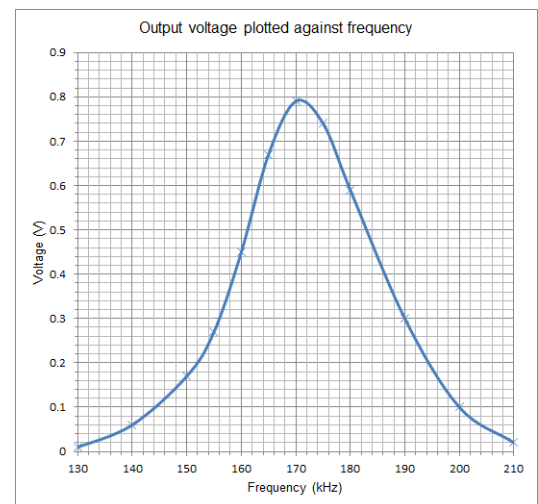
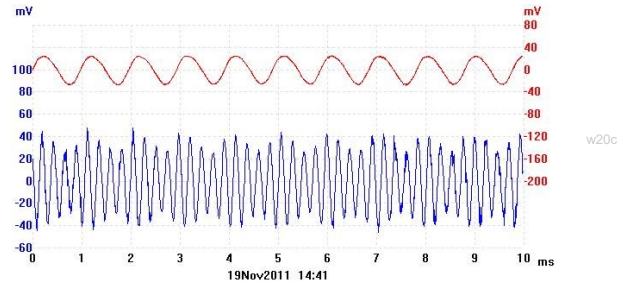

For your records:

Write short descriptions for the following terms, using diagrams to make your ideas clearer:

- depth of modulation;
- receiver sensitivity;
- receiver selectivity.

About these questions

These questions are designed to provide you with a useful aid to revision.
You should allow 15 minutes to answer them.

1. The component shown is:

- (a) a diode
- (b) a resistor
- (c) a fuse
- (d) a capacitor.

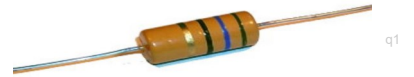

2. The symbol shown is:

- (a) a diode
- (b) an NPN transistor
- (c) a PNP transistor
- (d) an operational amplifier.

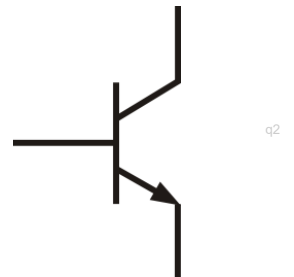

3. Three 6V batteries are connected in series.

Which one of the following gives the voltage produced?

- (a) 2V
- (b) 3V
- (c) 6V
- (d) 18V,

4. In the circuit shown:

- (a) R1 and R2 are in series, R4 and R5 are in parallel
- (b) R1 and R2 are in parallel, R4 and R5 are in series
- (c) R1 and R2 are in parallel, R4 and R5 are in parallel
- (d) R1 and R2 are in series, R4 and R5 are in series.

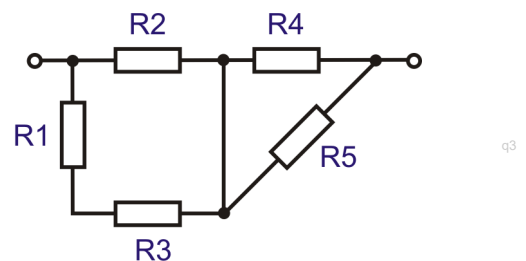

5. The symbol shown is:

- (a) a diode
- (b) a NPN transistor
- (c) a PNP transistor
- (d) an operational amplifier.

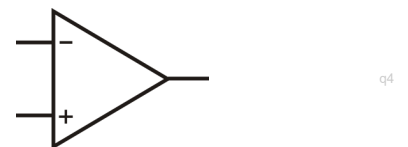

6. The component shown is:

- (a) a thermistor
- (b) a transistor
- (c) a transformer
- (d) a resistor.



7. Which one of the symbols shows a NOR gate?

- (a) A
- (b) B
- (c) C
- (d) D.

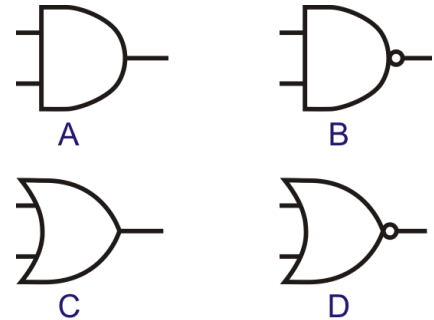

8. Operational amplifiers have:

- (a) very low open-loop voltage gain
- (b) very high open-loop voltage gain
- (c) very low input resistance
- (d) very high output resistance.

9. The closed-loop voltage gain of the amplifier shown in the diagram is determined by:

- (a) $R1 + R2$
- (b) $R1/R2$
- (c) $R2/R1$
- (d) $R1/R2$.

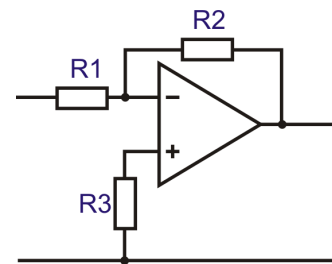

10. The truth table describes the logic function known as:

- (a) AND
- (b) OR
- (c) NAND
- (d) NOR.

Input A	Input B	Output
0	0	0
0	1	0
1	0	0
1	1	1

11. The logic circuit acts as a two-input:

- (a) AND gate
- (b) OR gate
- (c) NAND gate
- (d) NOR gate.

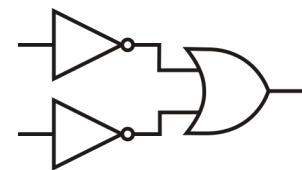

12. The waveform shown is:

- (a) an amplitude modulated sine wave
- (b) a frequency modulated sine wave
- (c) a digital pulse waveform
- (d) a variable frequency sine wave.

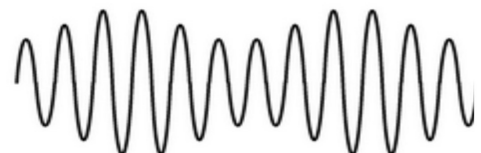

Now check your answers with those given on page 58.

Introduction

The course is essentially a practical one. Locktronics equipment makes it simple and quick to construct and investigate electrical and electronic circuits. Thanks to the symbols printed on each component carrier, the end result can look exactly like the circuit diagram.

Aim

The course provides a broad-based introduction to electronics and provides substantial syllabus coverage of the relevant BTEC First Award (Unit 7). It provides a series of practical investigations that allow students to unify theoretical work with practical skills.

Prior Knowledge

It is recommended that students have followed the 'Electricity Matters 1' and 'Electricity Matters 2' courses, or have equivalent knowledge of simple circuits and basic measuring instruments.

Learning Objectives

On successful completion of this course the student will:

- recall the characteristics of analogue and digital signals;
- recall that analogue signals can have any voltage value, usually limited by the power supply voltages;
- recall that digital quantities have only two possible states, known as 'off' and 'on', 'logic 0' and 'logic 1' or 'high' and 'low';
- make voltage, current and resistance measurements in DC circuits;
- measure the following quantities in AC circuits:
 - amplitude, peak-peak voltage, pulse duration, mark to space ratio, repetition ratio, period;
- use a LED and series resistor to display the output state of a logic system;
- use and identify a variety of common electronic components including cells, batteries, power supplies, connectors, resistors, capacitors, and diodes;
- set up a switch unit to output a digital logic signal when the switch is pressed;
- identify and use a range of transducers and indicators (e.g. phototransistor, lamp, LED, microphone, etc.);
- test and hence identify a logic function using switches LED logic indicators;
- identify series and parallel arrangements of components;
- recall the operation of a diode as a one-way device;
- describe the operation of bipolar junction transistors and their use in switching and amplifier circuits;
- recall the operation of operational amplifiers and their use as inverting and non-inverting voltage amplifiers;
- describe the operation of 555 timers in astable and monostable circuits;
- identify logic levels used in CMOS logic circuits;
- identify a logic gate from its symbol;
- complete the truth tables that describe NOT, AND, NAND, OR and NOR logic functions;
- be able to connect NAND gates to perform the following logic functions: NOT, AND, OR and NOR;
- be able to state one advantage of replacing logic gates with their NAND gate equivalent;
- distinguish between amplitude modulation and frequency modulation;
- investigate the operation of a simple AM communication system.

What the student will need:

To complete the course, the student will need the equipment shown in the table.

In addition the student will need:

- 1 digital multimeter
- 1 oscilloscope (single or dual beam)
- 1 audio frequency signal generator
- 1 radio frequency signal generator

In order to carry out the thermistor investigation (Worksheet 5,) students will need a temperature sensing probe and a small hair dryer.

Power source:

The investigations in this module require a DC power source such as the HP2666 which is an adjustable DC power supply, offering output voltages of 3V, 4.5V, 6V, 7.5V, 9V or 12V, with currents typically up to 1A.

The voltage is changed by turning the selector dial just above the earth pin until the arrow points to the required voltage.

(The instructor may decide to make any adjustment necessary to the power supply voltage, or may allow students to make those changes.)



Locktronics HP2666 power supply showing voltage selector

Qty	Code	Description
2	HP2666	Power supply
2	HP4039	Tray Lid
2	HP5540	Deep tray
3	HP7750	Daughter tray foam cutout
1	HP9564	62mm daughter tray
3	LK2346	MES bulb, 12V, 0.1A
1	LK3982	Voltmeter, 0V to 15V
1	LK4000	Locktronics User Guide
1	LK4002	Resistor, 100 ohm, 1W, 5% (DIN)
2	LK5202	Resistor, 1k, 1/4W, 5% (DIN)
2	LK5203	Resistor, 10k, 1/4W, 5% (DIN)
1	LK5214	Potentiometer, 10k (DIN)
2	LK5218	Resistor, 100k, 1/4W, 5% (DIN)
1	LK5224	Capacitor, 47uF, Electrolytic, 25V
2	LK5240	Transistor RHF, NPN
1	LK8000	Diode, Shottky
1	LK5243	Diode, power, 1A, 50V
18	LK5250	Connecting Link
1	LK5255	Transistor RHF, PNP
3	LK5291	Lampholder, MES
1	LK5402	Thermistor, 4.7k, NTC (DIN)
2	LK5607	Lead, yellow, 500mm, 4mm to 4mm stackable
2	LK5609	Lead, blue, 500mm, 4mm to 4mm stackable
2	LK6206	Capacitor. 4.7uF, electrolytic, 25V
1	LK6207	Switch, push to make, metal strip
2	LK6209	Switch, on/off, metal strip
1	LK6214r1	Choke, 10mH
2	LK6216	Capacitor, 0.47 uF, Polyester
1	LK6234L	Op Amp Carrier (TL081) with 2mm to 4mm Leads
1	LK6231	Resistor, 50k, 1/4W, 5% (DIN)
1	LK6283	Capacitor, 100pF, Ceramic
1	LK6299	Capacitor, 4n7, Ceramic
1	LK7582L	Systems block, 555 timer, with 4mm to 2mm lead
1	LK6423	Buzzer, 6V, 15mA
1	LK6492	Curriculum CD ROM
2	LK6635	LED, red, 5V (SB)
1	LK6706	Motor 3 to 12V DC, 0.7A
1	LK6860L	AND Gate with 2mm to 4mm lead - ANSI
1	LK6861L	OR Gate with 2mm to 4mm lead - ANSI
1	LK6862L	NOT Gate with 2mm to 4mm lead - ANSI
1	LK6863L	NAND Gate with 2mm to 4mm lead - ANSI
1	LK6864L	NOR Gate with 2mm to 4mm lead - ANSI
1	LK7290	Phototransistor
1	LK7483	1:1 transformer with retractable ferrite core
1	LK8275	Power supply carrier with battery symbol
1	LK8492	Dual rail power supply carrier
1	LK8900	7 x 5 metric baseboard with 4mm pillars
1	LK8932	Speaker
1	LK9381	Ammeter, 0mA to 100mA
1	LK9438	Voltmeter, +/- 7.5V

Using this course:

It is expected that the series of investigations provided in this pack is integrated with teaching or small group tutorials which introduce the theory behind the practical work, and reinforce it with written examples, assignments and calculations.

The worksheets should be printed / photocopied / laminated, preferably in colour, for the students' use. Students should be encouraged to make their own notes, and copy the results tables and sections marked 'For your records' for themselves. They are unlikely to need their own permanent copy of each worksheet.

Worksheets have:

- an introduction to the topic under investigation;
- step-by-step instructions for the investigation that follows;
- a section headed 'So What', which aims to collate and summarise the results, offer some extension work and encourage development of ideas, through collaboration with partners and with instructors.
- a section headed 'For your records', to be copied and completed in students' exercise books.

This format encourages student-centred learning, with students working at a rate that suits their ability. It is for the instructor to monitor that students' understanding is keeping pace with their progress through the worksheets.

One way to do this is to 'sign off' each worksheet, as a student completes it, and in the process have a brief chat with the student to assess grasp of the ideas involved in the exercises it contains. It is also important to ensure that additional work is available to 'stretch' learners as well as providing additional support for those that have difficulty with the topic.

Time:

It will take students between seven and eleven hours to complete all of the worksheets.

It is expected that a similar length of time will be needed to support the learning that takes place as a result.

Worksheet	Notes for the Instructor	Time
1	<p>The aim is to distinguish between analogue and digital signals.</p> <p>The worksheet sets up two sensing sub-systems, one analogue and the other digital.</p> <p>Students are directed to take voltage measurements on a digital multimeter (DMM). Some may not have done so for some time, and may need a reminder of how to do so. The first issue is that they use the correct sockets on the meter. The second is that they choose an appropriate scale. As the meter can measure AC quantities as well as DC, the instructor should remind them of the symbols used for AC and for DC ranges. The DC symbol is given on the worksheet.</p> <p>No record of measurements is taken, as it is simply a matter of realising that the analogue signal can take any value (between 0V and 6V - i.e. the power supply voltages) whereas the digital signal has one of two distinct voltage levels.</p> <p>The 'So What' section makes the point that, because of the nature of electrical signal transmission, digital signals are represented by bands of voltages, so that, in a TTL system, (Transistor-Transistor-Logic,) one of the logic gate families, any voltage from 0V to 0.8V is guaranteed to be taken as logic 0, and anything from 3.5V to 5V (the maximum voltage for a TTL system,) as logic 1. Signals may have voltages between these bands (unfortunately,) and for these the outcome is ambiguous. The system will regard them as either logic 0 or logic 1, but exactly which, is uncertain and may vary from system to system, and even from day to day.</p> <p>The section also introduces the idea of regeneration, where a digital signal can be returned to its original state, removing the effects of added noise signals, and of distortion, (where the components of the system do not reproduce the signal accurately.) This is not possible with an analogue signal. (The other advantage of digital processing is that it allows error detection, and correction, whereas analogue signals do not.)</p> <p>The logical nature of logic circuits is demonstrated as the last activity of this worksheet. Students find that if you turn the switching unit upside down, you turn the signal 'upside down'. Initially, pressing the switch generated a logic 1 signal, and not pressing it a logic 0. Once the switch unit is inverted, pressing the switch generates a logic 0, and not pressing it a logic 1.</p>	20 - 30 min
2	<p>In this worksheet students investigate the use of circuit symbols as an efficient way of describing the structure of a circuit.</p> <p>As an introduction, students could be shown, or could find for themselves, a number of common non-electrical symbols, such as road signs, to demonstrate that these pictorial messages are quick and easy to understand. They should be encouraged to learn the basic circuit symbols, and research a range of others.</p> <p>The students are then asked to build, and comment on six circuits, as practice in interpreting circuit diagrams. They should be reminded to select the correct power supply voltage for each. The circuits also show, again, the effect of placing a switch in different positions in the circuit.</p>	20 - 30 min

Worksheet	Notes for the Instructor	Time
3	<p>In the third worksheet students are introduced to resistors. The effect of resistance on the current flowing in a circuit is demonstrated by the use of small light bulbs.</p> <p>Students can be given the opportunity of making their own resistor using a length of pencil lead and investigating the effect that this has when placed between the two terminal posts. By this means, students quickly gain an understanding of resistance and its effect on the current flowing in a circuit.</p> <p>This investigation also introduces students to the concept of a series circuit in which one resistance follows another. To reinforce this, tutors may wish to use an analogy in which water flows from one point to another, passing through several restrictions on its way.</p> <p>If time permits, tutors may wish to demonstrate techniques used for measuring resistance:</p> <ul style="list-style-type: none">• measuring applied voltage, V, and current, I, (and calculating the ratio of V to I);• using the Ohms range on a multimeter. <p>Students can be given a variety of resistors to identify and measure.</p> <p>At this point, tutors could demonstrate (and give practice in) the use of the four-band and five-band resistor colour codes.</p> <p>Finally it is worth introducing students to the construction and operation of variable resistors, both wire-wound and carbon track format. Students should be reminded that these components usually have three (rather than two) terminals and this can usefully lead on to a discussion of the operation of a voltage divider circuit.</p>	20 - 30 min
4	<p>The use of a switch is investigated.</p> <p>The structure is examined to show that in the 'off' position, a layer of air prevents an electric current.</p> <p>The student is encouraged to try different configurations to control one or two lamps.</p> <p>There is a large number of switch types available. Two broad categories are introduced, the 'push' switch (or momentary acting switch,) and the toggle (or latching) switch. Students could be set the task of researching other types of switch, and applications in which they could be used.</p>	20 - 30 min

Worksheet	Notes for the Instructor	Time
5	<p>Students look at the effect of changing temperature on the resistance of a thermistor, and then design an experiment to investigate how light intensity affects the resistance of a phototransistor.</p> <p>Be aware that the first investigation uses a hair dryer which might pose a hazard if not used carefully!</p> <p>The investigation also requires the use of a digital temperature probe or thermometer. The probe may be used in conjunction with a digital multimeter or could take the form of a simple domestic confectionery thermometer (available at reasonable cost from most cook shops).</p> <p>Where a liquid-in-glass mercury thermometer is used, students must be made aware of suitable safety precautions.</p> <p>Students should confine their investigation to a modest range of temperature; e.g. room temperature to 60°C. Better results are obtained if the probe is held close to the thermistor element using a small bead of plasticine or Blu-tack, and if the temperature of the thermistor is first raised using the hair dryer and then allowed to cool slowly, with the hair dryer turned off. Students should take readings every 5°C as the thermistor cools. This will typically take between ten and fifteen minutes.</p> <p>They design an experiment to study the effect of light intensity on the resistance of the phototransistor. They may a reminder about the need to make it a fair test. In particular, all other possible influences should be kept constant throughout. The instructor may wish to provide them with a light-meter to measure the intensity. The units of light intensity are complex, and beyond the present course of study. The pupils should use whatever units the meter is calibrated in!</p>	30 - 45 min
6	<p>In this worksheet students investigate two common components that, unlike resistors, do not have a linear V/I characteristic. A simple arrangement is used to control the voltage and current through the components.</p> <p>The terms 'forward-biased' and 'reverse-biased' are introduced, but may need reinforcement by the tutor.</p> <p>The students plot graphs to show their results for the diode and the LED, and are given the generalised, and approximate, result that the forward voltage drop for the diode is 0.7V and for the LED is 2V.</p> <p>The worksheet ends with a summary of the findings.</p>	20 - 30 min
7	<p>Series and parallel circuits are introduced in this worksheet. At this level students often have difficulty in distinguishing between series and parallel connections and this worksheet aims to address this particular problem.</p> <p>Students build and test a variety of different series / parallel circuit arrangements in which bulbs provide a visual indication of the relative amounts of current flowing.</p> <p>Students should be reminded that they will inevitably be working with much more complex circuits in which a variety of different types of electronic component will be present. However, they do need to be able to reliably recognise which components are connected in series and which are connected in parallel.</p>	20 - 30 min

Worksheet	Notes for the Instructor	Time
8	<p>The worksheet starts with the necessary distinction between logic gates and logic functions. The more important is the logic function, as there are a number of ways to implement it. You could use a discrete logic gate, or a series of NAND gates, or NOR gates, or use a programmable system. On a wider front, optical logic gates produce the same logic functions, but using laser light, to speed up the switching process. The technology is different, but the outcome is the same. The introduction also contains a useful table of logic symbols, in both ANSI, and BS format.</p> <p>The simplest logic gate, the NOT gate, is introduced. The investigation involves setting up a switch unit to generate a digital input signal for the NOT gate. The students construct a voltage truth-table for the NOT gate. They then invert the switch unit, to show that this has no effect on the NOT function itself.</p> <p>The 'So What' section details the voltage bands used by CMOS gates (like the one in the Locktronics NOT gate carrier), and students use this to turn their voltage measurements into logic levels, and re-build the truth-table.</p> <p>They then investigate what happens when the resistor is removed from the switch unit. In general, for CMOS gates, inputs should not be allowed to 'float', but instead must be either 'pulled down' to the 0V rail, or 'pulled-up' to the positive power rail, by a resistor. The Locktronics NOT carrier has these inputs connected internally to 0V by a large value resistor.</p> <p>Finally, students check the serial number of the chip used in the NOT carrier. CMOS NOT gates carry the serial number 4049. However, the one used on the carrier may be a 4011 - a NAND gate. This flags up that it is often more appropriate to generate logic functions using other logic gates.</p>	20 - 30 min
9	<p>Students investigate the behaviour of an AND gate. The worksheet gives two situations where the AND function might be encountered in a car.</p> <p>The introduction points out a simple way to view the AND function as two switches in series, and the instructor should spend time to drive home this picture. The diagram includes a pull-down resistor, to ensure that output sits at logic 0 when either switch is open. Again, the significance of this needs to be emphasised.</p> <p>Students set up two switch units and use them to input four combinations of logic signals. Measuring input and output voltages, they complete a table of results, which they then turn into logic levels, and generate the AND gate truth-table.</p> <p>They are encouraged to view the AND function as one which generates a logic 1 output only when both inputs are at logic 1.</p> <p>The 'So What' section includes the pin out for a CMOS 4081 IC, and highlights the importance of avoiding floating inputs. Zealous students may take this message too far, and connect unused outputs to the nearest power rail. This is unfortunate, because the logic function applied by the gate may try to drive the output to logic 1, when the student has connected it to the 0V rail, or vice-versa. The message then is that the outputs take care of themselves. It is only unused inputs that require our attention.</p>	20 - 30 min

Worksheet	Notes for the Instructor	Time
10	<p>The OR gate is investigated in the same way.</p> <p>The introduction shows how two switches in parallel can produce the OR function. The diagram includes a pull-down resistor. The significance of both should to be emphasised by the instructor.</p> <p>The worksheet discusses a typical application, the car security system, though the details of the sensors used will decide what logic function is needed.</p> <p>Finally, the discussion in the 'So What' section leads to the building of the truth-table for the OR gate.</p>	20 - 30 min
11	<p>This worksheet investigates the NAND gate. Students set up two switch units to input the four combinations of logic signals. Measuring input and output voltages, they complete a table of results, which they then turn into logic levels, to generate the NAND gate truth-table.</p> <p>They are encouraged to view the NAND function as one which generates a logic 1 output when either input is at logic 0. The seat belt warning system in a car is given as a possible application. In reality, it depends on how the seat belt sensor is set up. This application assumes that it outputs a logic 0 when the seat belt is not fastened, and a logic 1 when it is, and further assumes that the alarm is triggered when the logic function outputs a logic 0. Other configurations require a different logic function.</p> <p>Students reproduce the effect of a NOT gate by connecting the inputs of the NAND gate together with a connecting link, and then use one switch unit to input digital signals. They verify that this arrangement generates the NOT logic function.</p> <p>Next, they build a combination of AND and NOT gates to show that these generate the NAND function. A diagram shows this using circuit symbols.</p> <p>Diagrams show how NAND gates can be combined together to produce any other logic functions. Students may wish, or might be directed, to set up these systems to confirm what happens. Some justification is given for this substitution in terms of reducing purchase and storage costs when only one type of IC is used.</p>	20 - 30 min
12	<p>The NOR function is the last of the five to be studied, but not because of low importance. The introduction points out that, like the NAND gate, NOR gates can be combined to generate any logic function. The diagrams in the introduction show how this is done. (The reason why NAND and NOR gates offer this facility, while AND and OR gates do not, stems from the ability of NAND and NOR to generate NOT functions. From there, all other functions are accessible.)</p> <p>The truth-table is investigated as before. It is seen to be the inverse of the OR gate, and so the students are asked to build a system using an OR and a NOT gate to generate the NOR function.</p> <p>Any application which 'turns something off' when anything 'turns on' requires a NOR function. This worksheet discusses the air-conditioning in a vehicle, which turns off when any door is opened. As usual, the exact requirements depend on the way the sensors are oriented.</p>	20 - 30 min

Worksheet	Notes for the Instructor	Time
13	<p>The instructor could remind students that a transistor comprises two PN junctions, each acting as a diode, conducting current in one direction only, followed by a demonstration of the transistor check facility on a multimeter, or transistor tester Alternatively tutors could show how forward and reverse resistance readings can indicate the 'go/no-go' status of each junction.</p> <p>Students adopt a third method, and measure the collector current with and without base current applied. With no base current, there is no measurable amount of collector current (Leakage current should be negligible). When base current is applied, the collector current is be measurable, typically around 5.4mA for a base current of around 54µA. The 100Ω resistor in series with the meter is there to limit current in the event of a short-circuit.</p> <p>Tutors could provide students with some defective transistors (i.e. open-circuit and/or short-circuit devices) to test. Students should be able to identify 'good' and 'bad' devices using the procedure from this investigation.</p>	20 - 30 min
14	<p>In this worksheet, students investigate the use of a transistor as a switch i.e. in positive and negative saturation . They begin by building and testing the simple LED switching circuit, making voltage measurements to illustrate the conditions when the switch is closed. Results for this part may be spurious because the base and collector are floating. A high value resistor in parallel with the load will resolve this.</p> <p>Next they build the motor on/off control circuit . Note that a much lower value of base resistor is used, to produce the increased collector current. They measure and record the voltage across the load, and should find that this is either 0V (with the switch open) or 6V (with it closed).</p>	30 - 45 min
15	<p>Students build a common-emitter transistor amplifier as a practical application of transistors. Base bias current is sourced from the collector, to cope with variation in common-emitter current gain. Tutors need to explain the purpose of this bias and the function of the collector load resistor. Worked examples will yield typical voltage and current values at the base and collector against which students can compare their measured results.</p> <p>Students will need a dual-channel oscilloscope to display input and output waveforms. Instruction on using this may be needed before students begin. Remind students that the common ground connection to the oscilloscope should be taken to the negative supply rail.</p> <p>Typical results: Collector voltage = 3.8V Base voltage = 0.67V</p> <p>Students should adjust the display to view at least two cycles of the input and output waveforms, and then sketch them, making sure to include labelled axes of voltage and time. Where a virtual instrument is used, the screen data can be captured and transferred as an image file.</p> <p>Students measure the peak-to-peak voltages at the input and output and use these to calculate the voltage gain of the amplifier. Typically, an output of 4V peak-peak results from a 50mV peak-peak input at 1kHz, inferring a voltage gain of around 80.</p> <p>Finally, they investigate the effect of over-driving the amplifier input by increasing the input voltage from to around 100mV pk-pk. The maximum undistorted output voltage is around 5V pk-pk.</p>	30 - 45 min

Worksheet	Notes for the Instructor	Time
16	<p>The aim of an amplifier is that the output follows the input, but as a larger version of it. If the output saturates, it can no longer follow changes in the input. Linear amplifiers should never reach output saturation.</p> <p>Instructors should introduce the concept of negative feedback, and its benefit in controlling the huge open-loop voltage gain of the op-amp.</p> <p>The voltage gain of the amplifier is determined solely by the value of the two resistors, R_F and R_1, provided extreme values of gain or bandwidth are avoided. This investigation uses two pairs of resistor values, to give gains of 2x and 11x. The instructor may wish to add other values, or vary the values between different groups and then later collate results. Whilst amplifiers are usually associated with audio systems, the use of DC signals makes it easier to visualise what is happening and to make measurements.</p> <p>Students often confuse the general voltage gain formula ($A_v = V_{OUT} / V_{IN}$) and the voltage gain formula specific to the non-inverting amplifier, based on resistor values ($A_v = 1 + R_F/R_1$.) Instructors should provide a range of examples to reinforce the significance of both of these formulae.</p> <p>The analysis in 'So what?' introduces the ideal characteristics of op-amps. These need considerable reinforcement by the instructor, as some are fairly esoteric. The instructor should explore the meaning of input impedance, (which can be called input resistance here as we are dealing with DC signals. The reality is that many signal sources can generate a reasonable voltage, but are unable to deliver appreciable current. If the amplifier draws much current from these sources, the voltage transferred to the amplifier will be very small. Most of the signal voltage will be dropped across the output (but internal) resistance of the signal source.</p> <p>The significant advantage of the non-inverting amplifier over the inverting amplifier is that the former has a much higher input impedance, and so draws a much smaller current from the signal source.</p>	30 - 45 min
17	<p>This investigation mirrors that in the previous worksheet but now for the inverting amplifier. The voltage gain formula is applied to the results. The formula linking voltage gain to resistor values is given without proof, and will need additional examples to cement it into the students' minds.</p> <p>The 'So what?' section includes an important practical detail, that for any op-amp circuit where the output is not saturated, the two inputs sit at virtually the same voltage. Some students might puzzle at the role of the op-amp in the two voltage amplifier circuits. The voltage gain formulae make no mention of it! The answer is that the op-amp is trying its hardest to keep the two inputs at the same voltage. If the output saturates, then it has failed.</p> <p>Here is a very practical means of checking that the op-amp is functioning properly. Provided the output is not saturated, a multimeter connected to first one and then the other input should give the same reading.</p> <p>The point is also made that the input resistor, R_{IN}, should be as large as is practicable in order to keep a high input resistance for the amplifier (which really is equal to the value of the input resistor.)</p>	30 - 45 min

Worksheet	Notes for the Instructor	Time
18	<p>This investigation introduces the 555 timer. Students first construct and test a monostable timer, which produces a single output pulse of duration determined by the time constant of the C-R circuit. At this point, students should be asked to recall previous work on passive circuits and the significance of the time constant in a C-R circuit.</p> <p>In the first circuit, the monostable pulse period starts on the falling edge applied to the trigger circuit. Tutors should explain how this is generated by the switch unit.</p> <p>In the second circuit, the astable pulse generator outputs a continuous train of pulses. Due to the configuration employed, this circuit may not always start. If this is the case, students should momentarily disconnect the flying lead to the positive supply. Oscillation will then commence.</p>	30 - 45 min
19	<p>This investigation is optional, as it requires a radio receiver capable of long-wave (low frequency) band reception. If it is undertaken, students should be encouraged to keep all connecting leads as short as possible to reduce the effect of stray capacitance.</p> <p>They build a simple radio transmitter, with two stages, a modulator and a radio frequency oscillator. It produces an amplitude modulated (AM) signal with a frequency range from about 125kHz to 250kHz.</p> <p>The output power of the transmitter is extremely low, giving a range of only a few metres. The radio receiver should be tuned to receive the signals on an unused frequency around 250 kHz to avoid interference from stronger broadcast stations.</p> <p>The short ferrite rod, inserted into the transformer, is used for tuning. The actual frequency of operation depends not only on the inductance of the transformer coils but also on stray capacitance at the collector and base of the transistor. These are usually too small to measure with simple test instruments and so attempts to relate the output frequency to inductance and capacitance values are pointless. However, tutors may wish to introduce the relationship below, together with examples of its use, with typical values of inductance and capacitance found in this circuit e.g. C = 100 pF and L = 5 mH)</p> $f = \frac{1}{2\pi\sqrt{LC}}$ <p>A depth of modulation of about 30% will be achieved when the modulating signal has an amplitude of around 1V. Excessive modulation depths should be avoided as this will result in appreciable distortion. With a high-output dynamic microphone, the depth of modulation should be sufficient for voice signals to be heard clearly with the receiver placed several metres away from the transmitter.</p> <p>Tutors must ensure that there is no interference to broadcast and other services!</p>	30 - 45 min

Instructor's guide

Scheme of work



Worksheet	Notes for the Instructor	Time
20	<p>This investigation is optional, as some regions will not have sufficiently strong radio reception to make the receiver work. If it is undertaken, students should be encouraged to keep connecting leads as short as possible to reduce the effect of stray capacitance.</p> <p>Students build the circuit given and use it to investigate the operation of a simple radio receiver. The receiver uses three stages, a tuned circuit, diode demodulator (sometimes referred to as a 'detector') and an audio frequency amplifier. The circuit tunes (by means of the adjustable ferrite core) over the frequency range extending from about 130 kHz to 280 kHz.</p> <p>The receiver will produce signals from strong broadcast stations (e.g. BBC Radio 4) operating in the long wave (LF) band. In order to receive such signals a wire antenna (of typical length 10m to 20m) will be required.</p> <p>As with the simple transmitter, the ferrite rod, inserted into the transformer, is used for tuning. Again, measurement of inductance and capacitance will prove difficult. Instead, instructors can work through examples using the formula for resonant frequency given earlier.</p> <p>When a modulated signal is applied to the input from an RF signal generator, an audio signal will be heard on high impedance headphones. With the modulation switched off, the DC output from the operational amplifier can be used to plot a response curve (output voltage plotted against frequency) for the receiver. This will allow students to confirm the frequency of operation and obtain a value for the bandwidth of the receiver (typically about 20kHz).</p>	30 - 45 min

Instructor's guide

Scheme of work



Worksheet	Notes for the Instructor	Time
Quiz	<p>This is offered as a way to assess a student's grasp of the topics covered in the worksheets. The answers are given below:</p> <ol style="list-style-type: none">1. (b)2. (b)3. (d)4. (c)5. (d)6. (b)7. (d)8. (b)9. (c)10. (a)11. (c)12. (a)	15 min

Version control



Date	Release notes	Release version
24 04 2012	First version released	LK8293-1 Version 1
16 12 2014	Updated for RoHS compliance	LK8293-80-2
26 07 2017	Changed to new LK7582 555 timer	LK8293-80-3
29 06 20	Changed Germanium diode to Shottky - BOM only	LK8293 29 06 20

About this document:

Code: LK8293

Developed for product code LK3889- Intermediate electronic engineering