

locktronics

Simplifying Electricity

Aircraft Maintenance - Electrical Fundamentals 1



CP7378

MATRIX
www.matrixmultimedia.com

Copyright © 2010 Matrix Multimedia Limited

Contents



Worksheet 1 - Series and parallel circuits	3
Worksheet 2 - Measuring current	5
Worksheet 3 - Measuring voltage	7
Worksheet 4 - Cells and batteries	9
Worksheet 5 - Thermocouples	12
Worksheet 6 - Photocells	14
Worksheet 7 - Ohm's Law	16
Revision questions	19
Tutor's notes	21
Answers	28

Developed by Mike Tooley in conjunction with Matrix Technology Solutions Ltd

Worksheet 1

Series and parallel circuits

In some circuits, there is only one route that the electric current can follow from one side of the power supply to the other. In others, the current has a choice of route.

An electric current is a flow of negatively charged electrons. Overcrowded on the negative terminal of the battery, they flow around the circuit, attracted to the positive terminal.

A **series** circuit offers only one route around the circuit, from one end of the battery back to the other! There are no junctions in a series circuit.

A **parallel** circuit offers more than one route and so different currents can flow in different parts of the circuit.

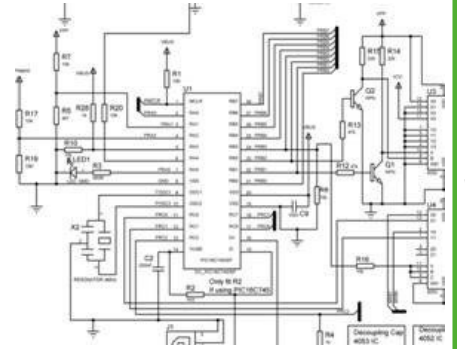

w1a

Over to you:

- Set up the arrangement shown, using three 6V 0.04A bulbs.
- The picture shows one way to set up this circuit.
- Make sure that the power supply is set to 9V!
- This is a series circuit - everything connected in a line, one after the other.
- There is only one way for electric current to get from one end of the power supply to the other. There are no junctions, no alternative routes!

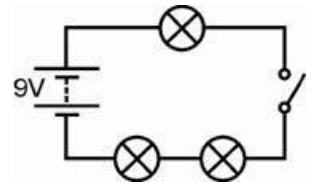

w1b

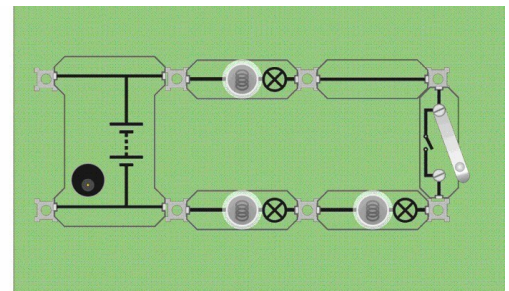

w1c

- Close the switch and notice how bright the bulbs look. Don't forget – the brighter the bulb, the greater the current flowing.
- Does it matter where you connect the switch? Try it in different places in the circuit.
- Unscrew one of the bulbs and notice the effect. Does it matter which bulb you unscrew?
- Does it look as if electric current is getting 'used up' as it goes round the circuit? (In other words, do the bulbs get dimmer as you move further round the circuit?) If they have the same brightness, then the current flowing through them must be the same.
- Now change the circuit for the one shown, still using 6V bulbs.
- Make sure that you change the power supply to 6V!
- This is not a series circuit — there are **two** ways to get from one end of the power supply to the other! Trace these routes out for yourself.
- Look at the brightness of the three bulbs. What does this tell us? Unscrew bulb A. What happens? Unscrew bulb B. What happens?

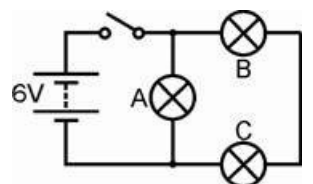

w1d

Worksheet 1

Series and parallel circuits

So what?

- This second circuit is not a series circuit as there are two ways to get from one side of the battery to the other:
 - Bulb A is connected in parallel with the other two bulbs.
 - Bulb B is in series with bulb C because they are on the same route.
- In the second arrangement, one route for the current goes through only one bulb. The other goes through two bulbs, and so is twice as difficult for the electrons. Most take the easy route through just the one bulb. More electrons per second = bigger current
- **A challenge!**
 - Change the circuit so that the switch controls only bulbs B and C, **BUT** you can only move one connection to achieve this.

For your records:

- A series circuit offers only one route for the electric current.
- If a break appears anywhere in the circuit, then the electric current stops everywhere.
- If one bulb fails in the circuit, then all the bulbs go out.
- The electric current is the same size throughout the circuit.
- A parallel circuit offers more than one route and so different currents can flow in different parts of the circuit.
- Copy the circuit diagram and answer these questions:
 1. Bulb B is in series with bulb
 2. Bulb C is in with bulb E and bulb F.
 3. Bulbs B and D are in with bulbs C, E and F.
 4. The biggest current will flow through bulb
 5. Bulb will be the brightest bulb.
- Explain to your partner how your observations support the idea that electrons prefer to follow the easier route.

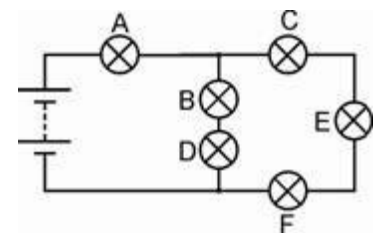

w1e

Worksheet 2

Measuring current

In worksheet 1, we used the brightness of the bulbs as a measure of the size of the current.

This is too crude for a number of reasons:



- Bulbs are mass-produced and so not identical;
- It is difficult to judge small differences in brightness when the currents are very similar in size;
- It doesn't work if the current is too small to light the bulb!

Ammeters offer a much more reliable way of measuring current.

We also need ways of measuring voltage and resistance.

A multimeter is a convenient and cheap way to measure a range of electrical quantities such as current, voltage and resistance. The photograph shows the controls on a typical multimeter.

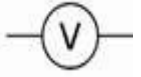
Meter Symbols



Ammeter	
Voltmeter	
Ohmmeter	



Using a multimeter to measure current:

A multimeter can measure either AC or DC quantities.

The following symbols are used to distinguish between the two:

AC 
DC 

- Plug one wire into the black COM socket.
- Plug another into the red mA socket.
- Select the 200mA DC range by turning the dial to the '200m' mark next to the 'A ' symbol.
- Break the circuit where you want to measure the current, by removing a link, and then plug the two wires in its place.
- Press the red ON/OFF switch when you are ready to take a reading.

A possible problem!

The ammeter range is protected by a fuse located inside the body of the multimeter. This fuse may have 'blown', in which case the ammeter range will not work. Report any problems to your instructor so that they can check the fuse.

Worksheet 2

Measuring current



Over to you:

- Set up the arrangement shown, using 6V 0.04A bulbs.
- Make sure that the power supply is set to 9V.
- This is a series circuit - only one route for electric current around the circuit.
- Measure the current flowing at point P. To do this, plug the wires from the ammeter into the two posts at either end of the link at point P, and then remove the link. This is shown in the picture.
- Now replace the link at P. Measure the current at point Q in the same way.
- Measure the current at points R and S in the same way.
- Next, investigate the currents flowing at points P, Q, R etc. in the following circuits.
- Notice the power supply voltage is different for each!

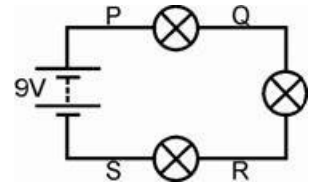

See if you can spot a pattern for the behaviour!

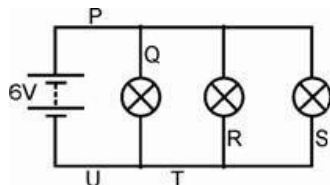

can spot a

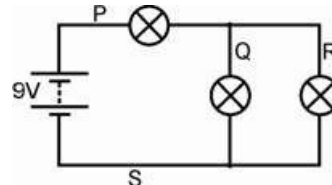

pattern for the behaviour!

For your records:

- In a series circuit, the current flows in all parts.
- In a parallel circuit, the currents in all the parallel branches add up to the current leaving the
- Copy the following circuit diagrams, and calculate the readings on ammeters A to H.

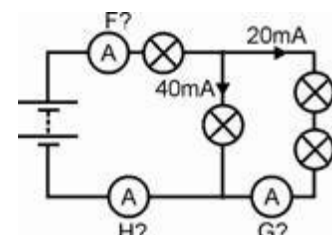
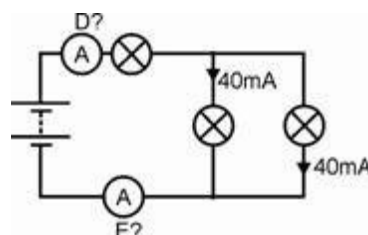
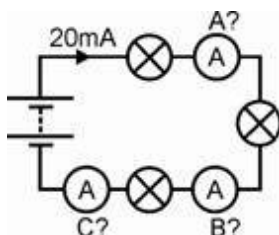

Worksheet 3

Measuring voltage

We can visualise electric current reasonably easily—it's the flow of tiny electrons around the circuit. More precisely, current measures the number of electrons per second passing a particular point in the circuit.

It is more difficult to picture voltage.

You can think of it as the pressure that causes current to flow.

The bigger the power supply voltage, the more energy the electrons are given, and then give up, as they travel around the circuit.

However, it is easier to measure voltage than current.

No need to break the circuit—just add the voltmeter in parallel with the component you are interested in!

The important thing to remember:

Ammeters are connected in series whereas voltmeters are connected in parallel!

Meter Symbols

Ammeter 

Voltmeter 



Ohmmeter 



Using a multimeter to measure voltage:

A multimeter can measure either AC or DC quantities.

The following symbols are used to distinguish between the two:

AC 
DC 

- Plug one wire into the black COM socket.
- Plug another into the red V socket.
- Select the 20V DC range by turning the dial to the '20' mark next to the 'V —' symbol. (It is good practice to set the meter on a range that is much higher than the reading you are expecting. Then you can refine the measurement by choosing a lower range that suits the voltage you find.)
- Plug the two wires into the sockets at the ends of the component under investigation.
- Press the red ON/OFF switch when you are ready to take a reading.

A possible problem!

If you see a '-' sign in front of the reading, it means that the wires from the voltmeter are connected the wrong way round. Swap them over to correct this!

Worksheet 3

Measuring voltage



Over to you:

- Set up the arrangement shown, using 6V 0.04A bulbs, but without the voltmeters. This is a series circuit as there is only one route around it.
- Make sure that the power supply is set to 9V.
- Measure the voltage across the first bulb, by plugging the wires from the voltmeter into the posts at either end of the first bulb, as shown at P.
- Next, measure the voltage across the second bulb, by connecting the voltmeter as shown at Q.
- Then measure the voltage across the third bulb, by connecting the voltmeter as at point R.
- Add together the readings of the voltmeters at points P, Q and R. What do you notice about this total?
- Next investigate the voltages across bulbs P, Q, and R, (all 6V 0.04A) in the following circuits. (Notice that the power supply voltage is different for each!)

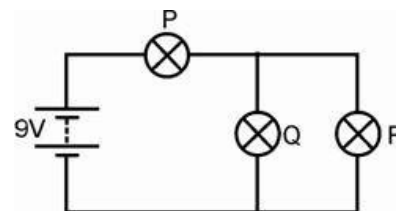
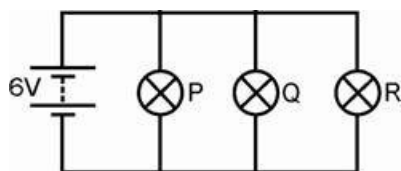
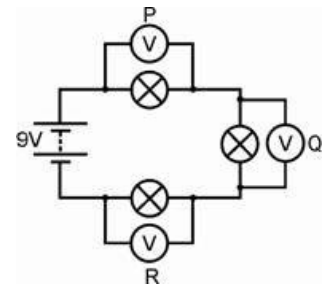

- See if you can spot a pattern for the behaviour.

For your records:

- In a series circuit, the voltages across the components add up to the voltage across the
- In a parallel circuit, the components all have the voltage across them.
- Copy the following circuit diagrams, and calculate the voltages across bulbs A to E.

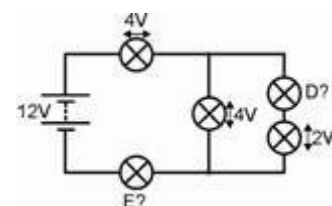
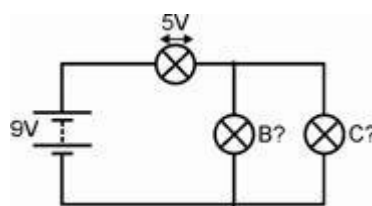
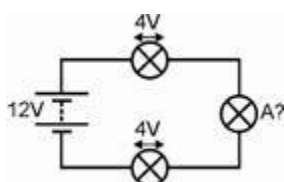

Worksheet 4

Cells and batteries

The individual cells that make up a battery are be classed as either **primary** or **secondary**.

In primary cells, the active constituents are exhausted at the end of the cell's life. Primary cells are not rechargeable.

In secondary cells, the chemical reaction is reversible, so that the cell can be re-used many times. These can be recharged.

Batteries consist of a number of individual cells, connected either in series or in parallel.

For example, a 24 V lead-acid battery will usually have 12 cells, each supplying an emf of 2 V, connected in series.

The emf produced by popular types of single-cell batteries are as follows:

Alkaline (primary dry cell)	1.5 V
Lead-acid (secondary cell)	2.0 V
Nickel-cadmium (secondary cell)	1.2 V
Zinc-carbon (primary dry cell)	1.5 V

Several different types of battery are used on aircraft These are categorized by the types of material used in their construction, and include **lead-acid** and **nickel-cadmium** batteries, used for the aircraft's main direct current (DC) supply.

The **main aircraft battery** (shown in the picture earlier) is a primary source of electrical power. Its use can be controlled by the pilot, or by automatic means. It provides **autonomous starting** for the main engine(s) or the auxiliary power unit (APU) when ground power is unavailable.

Other batteries are available to supply essential loads in the event of generator failure. It is an airworthiness requirement that the main battery is able to supply the aircraft's essential electrical and avionic services for a specified minimum period of time.

Other aircraft and avionic systems may be have their own dedicated batteries, e.g. emergency beacons. Batteries are also used to power non-volatile memories used in a variety of avionic and navigation systems.

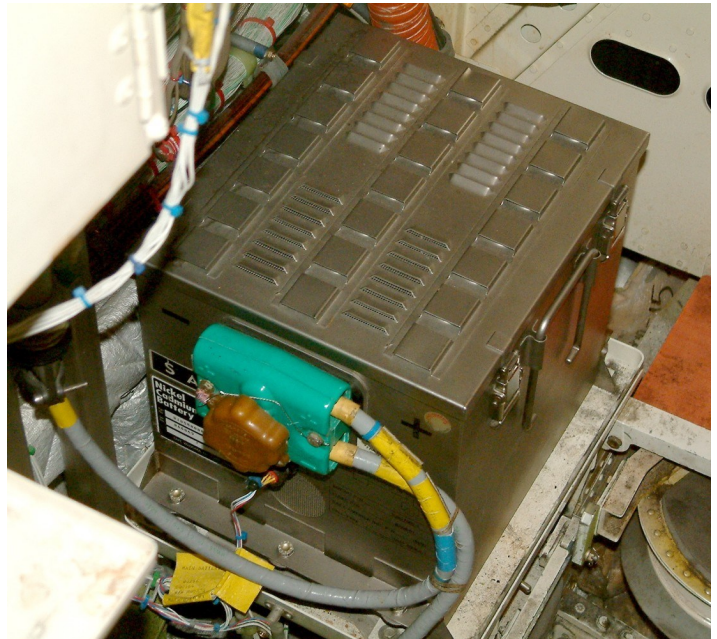

w4a

Worksheet 4

Cells and batteries

Over to you:

- Set up each of the arrangements shown below:

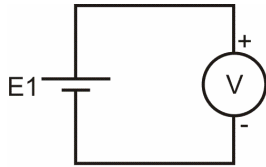

(a)

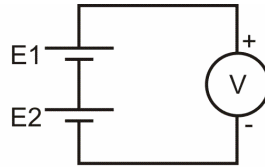

(b)

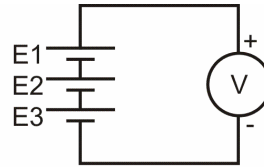

(c)

w4b

Circuit (a) contains a single cell.

Circuits (b) and (c) are batteries of two and three cells respectively, connected **in series**.

- The diagram shows one way to arrange these.
- Use a multimeter (set to the 20V DC range) to measure the output voltage (emf) of each cell, and then the output voltage of each complete battery.

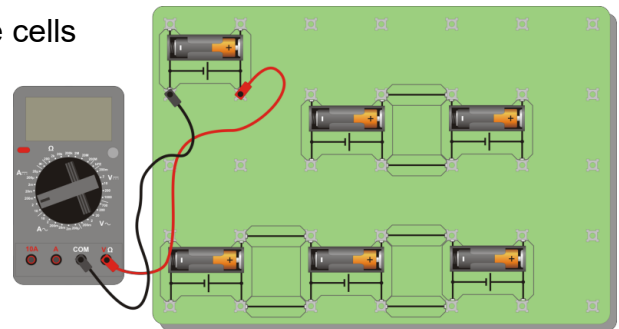

w4c

- Record your results in the tables.

Cell	Output voltage
E1	
E2	
E3	

Series connected battery	Output voltage
Two-cell battery	
Three-cell battery	

- Next, set up each of the **parallel-connected** arrangements shown below.

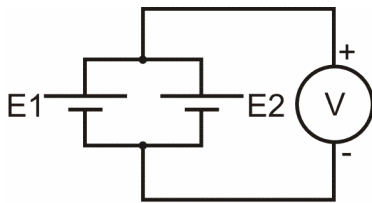

(d)

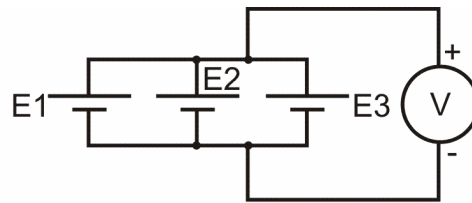

(e)

w4d

- As before, use a multimeter (set to the 20V DC range) to measure the output voltage of each battery, and record your results in the table below.

Parallel - connected battery	Output voltage
Two-cell battery	
Three-cell battery	

Worksheet 4

Cells and batteries



So what?

- For the two cell series-connected battery, theory predicts that the output voltage V should equal the sum of the emf's of the two cells, i.e.:

$$V = E_1 + E_2$$

- For the three cell series-connected battery, theory says, similarly, that

$$V = E_1 + E_2 + E_3$$

- In the case of the two cell parallel-connected battery, theory predicts that the output voltage V should equal the emf of each of the two cells, i.e.:

$$V = E_1 = E_2$$

- For the three cell series-connected battery, theory says that:

$$V = E_1 = E_2 = E_3$$

- Check that your measurements support these predictions.

For your records:

- Summarise the results of your investigations.

Your investigation looked at the effect on **output voltage** of combining cells in series and then in parallel.

As far as the **current** delivered is concerned:

- with a series-connected battery, the *same* load current flows through each of the cells.
- with a parallel-connected battery, the load current is *shared* between the cells.

Combining cells in series increases the output voltage, but the cells all deliver the full load current and so will go 'flat' quicker.

Combining cells in parallel does not increase the output voltage, the cells take longer to discharge, and the available load current may be greater because the load current is shared.

- Answer the following questions:

1. How many nickel-cadmium cells are required in a series-connected 24 V battery?
2. Two main batteries are connected in parallel in order to supply the 180 A load current demanded by a main engine starter. How much current is supplied by each ?
3. An emergency lamp uses eight conventional 1.5 V dry-cells connected in series. What voltage is the required to supply to the lamp?
4. A 24 V battery supplies 18 parallel-connected cabin emergency lights. If each light consumes 1.5 A what current is supplied by the battery?

(Compare your answers with those given at the end of the module.)

Worksheet 5

Thermocouples

When two wires made from different metals, are connected at both ends to form a complete circuit, a small emf is generated whenever the two junctions are at different temperatures.

This is known as a thermoelectric emf, and it can be used to measure the temperature of aircraft components (such as exhaust gas in a gas turbine engine).

Thermocouples use some rather exotic materials, such as:

- **chromel** - (an alloy containing 90% nickel and 10% chromium);
- **alumel** - (an alloy of 95% nickel, 2% manganese, 2% aluminium and 1% silicon);



Typical output voltages and temperature ranges for various thermocouples are:

Junction materials	Output voltage ($\mu\text{V}/^\circ\text{C}$)	Temperature range ($\mu\text{V}/^\circ\text{C}$)
Iron and constantan	41	-40 to +750
Chromel and alumel	41	-200 to +1200
Chromel and constantan	68	-270 to +790
Platinum and rhodium	10	+100 to +1800

The next investigation uses a chromel / alumel thermocouple probe, known as a 'type-K' thermocouple.

Over to you:

- Set up the thermocouple probe arrangement shown opposite.
- Place the thermocouple probe in a beaker of water, together with a mercury or digital thermometer.
- Use a multimeter (set to the 2V DC range) to measure the emf produced by the thermocouple at the temperatures listed in the table below.
- Record the results in the table:

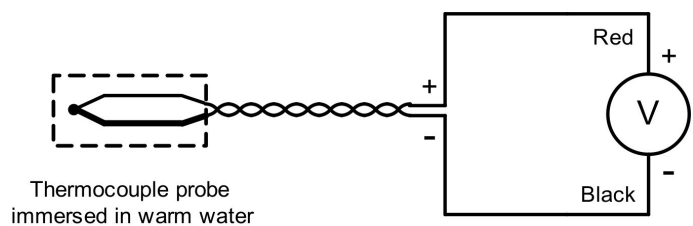

Temperature ($^\circ\text{C}$)	+10	+20	+30	+40	+50	+60	+70	+80
Emf (V)								

Worksheet 5

Thermocouples



So what?

Plot your graph on a separate sheet of graph paper or on the area below:

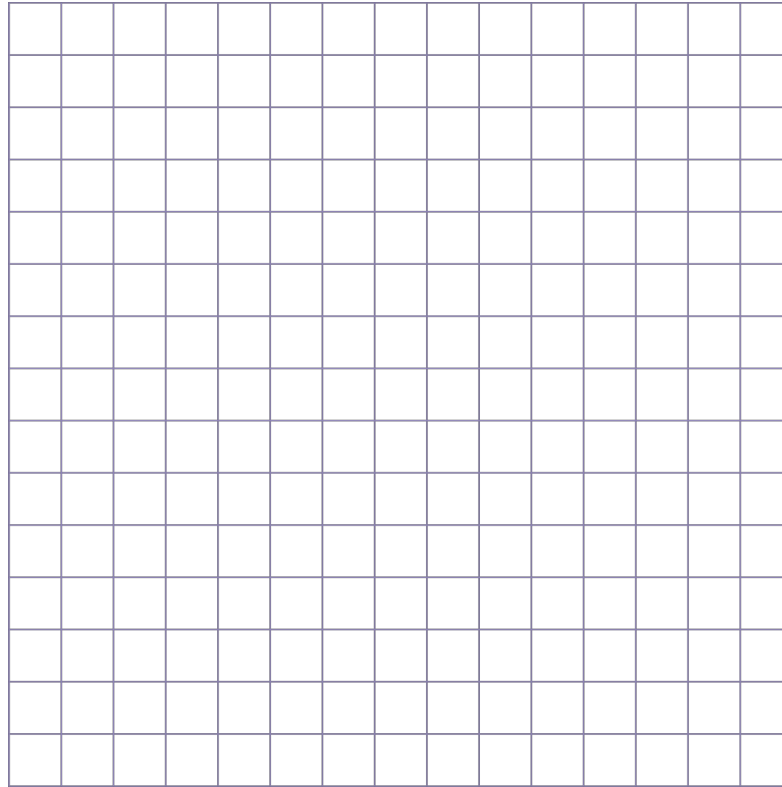

w5c

Use your graph to estimate the following:

the following:

Emf change for 80°C change in temperature = μV

Emf change for 1°C change in temperature = μV

For your records:

- Does the thermocouple probe you used have a linear characteristic? How do you know?
- Write an explanation in no more than fifty words on the factors that determine the thermoelectric emf generated by a thermocouple.
- Use the internet to find out about:
 - type-K thermocouples;
 - cold-junction compensation.

Worksheet 6

Photocells

Photocells (also often called solar cells,) use a process called *photovoltaic conversion* to convert light into electricity.

By 'doping' a crystal of silicon with small amounts of different impurity elements, it can be made into either 'N' or 'P' type material. The former has a surplus of free electrons whereas the latter has 'holes' in which free electrons can be trapped.

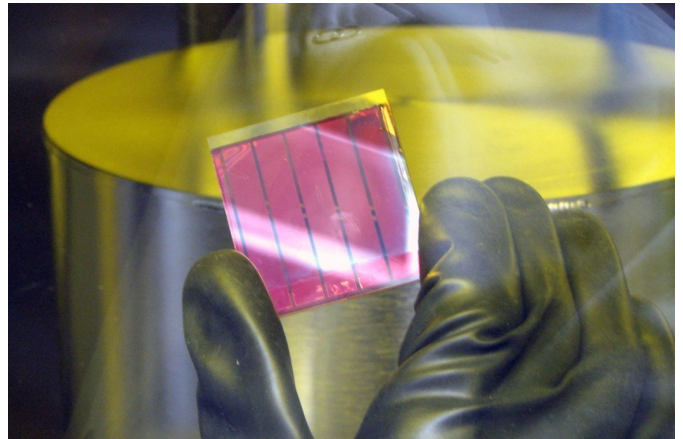

w6a

A photocell, like that shown in the picture, consists of two interacting layers of silicon, one N-type and the other P-type. Both layers have conducting tracks connected to them. Where the two layers meet an internal electric field is created. When light strikes this junction, an electron-hole pair is created. When these are separated, the P-region becomes positively charged whilst the N-region acquires an equal and opposite negative charge.

By this means a small emf is produced which will cause a current to flow in an external circuit to which the photocell is connected. As more light hits the photocell, more electrons will be released and thus more current and voltage will be generated. This photovoltaic process continues as long as light hits the cell.

Over to you:

- Set up the arrangement shown opposite.
- Place the photocell in:
 - bright sunlight;
 - shadow;
 - ordinary room light;
 - complete darkness.
- Use the multimeter (set to the 2V DC range) to measure the emf produced in each case.
- Record your results in the table:

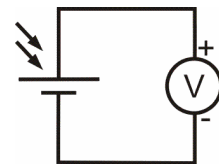

w6b

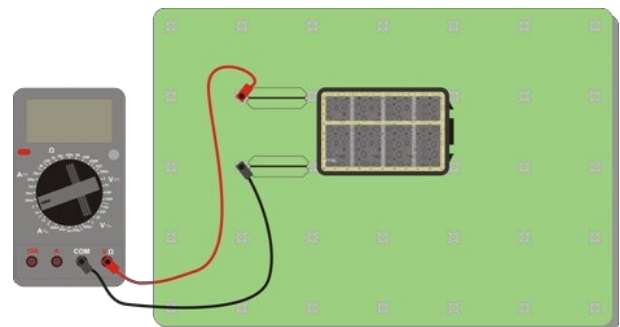

w6c

Light level	Photocell output
Bright sunlight	
Shadow	
Room light	
Darkness	

Worksheet 6

Photocells

For your records:

- Explain what is meant by photovoltaic conversion.
- Your investigation looked at the **voltage** generated by a photocell. Use the internet to identify factors that determine the **current** that be delivered by a photocell.
- Answer the following questions:



w6d

1. How many photocells like the one you studied , connected in series, would be needed to produce a photovoltaic battery with an output of 24V in bright sunlight?
2. An experimental twin-engine solar-powered pilotless aircraft has photovoltaic cells covering the upper surfaces of each wing. Each engine requires a power supply of 120 V at 10 A. Each solar cell generates 0.6 V at 0.5 A. How many solar cells are required in each battery, and how should they be connected?

(Compare your answers with those given at the end of the module.)



w6e

Worksheet 7

Ohm's law

Current measures how many electrons pass per second.

Voltage is a measure of how much energy the electrons gain or lose as they flow around a circuit.

Resistance shows how difficult it is for the electrons to pass through a material. In squeezing through, the electrons lose energy to the resistor, which warms up as a result.

The photograph shows George Simon Ohm—a significant figure in this study! Ohm's law leads to an important relationship in electricity:

$$V = I \times R$$



w7a

Over to you:

- Set up the arrangement shown in the diagram. The picture shows one way to do this. The variable resistor allows us to change the voltage across the 12Ω resistor.
- **Make sure that the power supply is set to 3V!**
- **Before you switch on**, select the **200mA DC** range on the ammeter, and the **20V DC** range on the voltmeter.
- Connect the red and black cables as shown. This ensures that the meters are connected the right way round and avoids '-' signs on the readings.
- Turn the variable resistor knob fully anticlockwise, to set the voltage supplied to a minimum.
- Turn the knob slowly clockwise until the voltage across the resistor reaches 0.1V. Then read the current flowing through the resistor.
- Turn the voltage up to 0.2V, and take the current reading again.
- Keep doing this until the voltage reaches 0.9V. **(Don't exceed this or the resistor may overheat!)**
- Write your results in the table opposite.

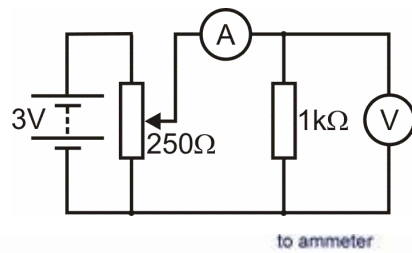

w7b

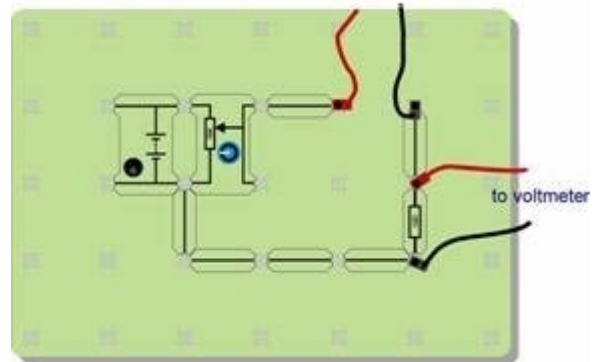

w7c

Voltage	Current
0.1	
0.2	
0.3	
0.4	
0.5	
0.6	
0.7	
0.8	
0.9	

Worksheet 7

Ohm's law

So what?

- Plot a graph to show your results.
- Ohm's law predicts a straight line, so draw the best straight line through your points.
- If you know how, calculate the gradient of your graph. Ohm's law calls this quantity the **resistance** of the resistor.

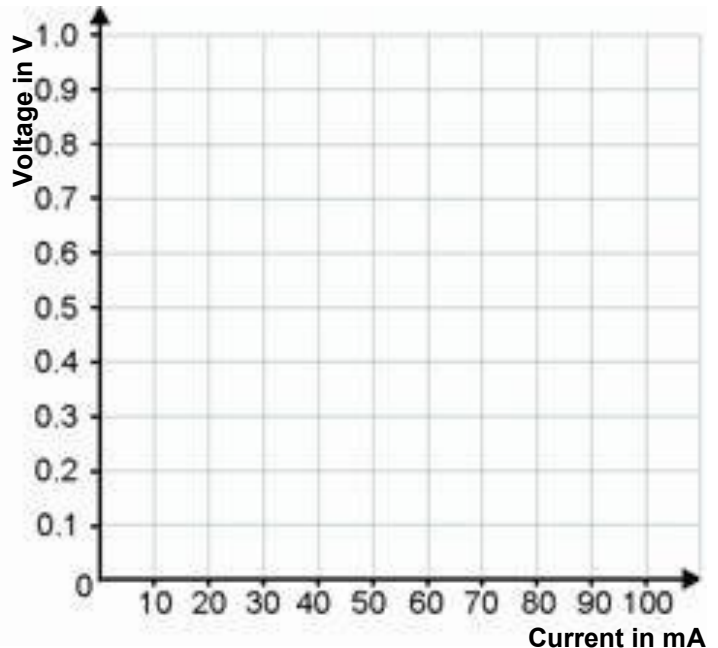

Resistor Colour Code:

Resistors often come with coloured bands across their body to show the value of the resistance. Each colour represents a number, as shown in the table.

Black	Brown	Red	Orange	Yellow	Green	Blue	Purple	Grey	White
0	1	2	3	4	5	6	7	8	9

To read the colour code:

- start from the opposite end to the gold or silver band;
- write down the number shown by the first colour band;
- write down the number shown the second colour band;
- add the number of 0's shown in the next band (e.g. for red, add two 0's.)
- The final band (usually gold, (5%) or silver (10%)) gives the tolerance (accuracy.)

For example, the resistors in the photograph have a resistance of:

$$\begin{aligned} &7 \text{ (purple)} 5 \text{ (green)} 000 \text{ (orange)} \\ &= 75000\Omega \\ &\text{and a tolerance of } 5\% \end{aligned}$$



Worksheet 7

Ohm's law

Using a multimeter to measure resistance:

You cannot measure the resistance of a component while it is in the circuit. It must be removed first.

- Plug one wire into the black COM socket, and the other into the V Ω socket.
- Select the 200kΩ range, (or a range which is much higher than the reading you are expecting.)
- Plug the two wires into the sockets at the ends of the component under investigation.
- Press the red ON/OFF switch when you are ready to take a reading.
- Turn the dial to choose a lower range, until you find the reading.

Note - 1 kΩ = 1000 Ω.



For your records:

- Ohm's law gives us the following equations:

$$V = I \times R \quad R = V / I \quad I = V / R$$

where **R** = resistance in ohms, **I** = current in amps and **V** = voltage.

(This also works when the resistance is in kilohms and the current in milliamps, because the kilo (thousands) and milli (thousandths) cancel out.)

- Calculate the missing quantities:

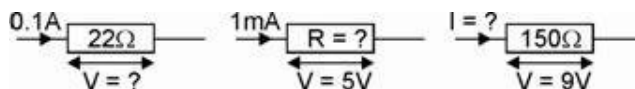

- The resistor colour code is used to show the resistance of a resistor.
- Use the colour code table given on the previous page to complete the following table:

Band 1	Band 2	Band 3	Resistance
Brown	Black	Yellow	
Green	Blue	Red	
Grey	Red	Black	

(Compare your answers with those given at the end of the module.)

Revision questions



About these revision questions

These questions are typical of those that you will be required to answer in the EASA Part-66 examination.

You should allow 15 minutes to answer these questions and then check your answers with those given at the end of the module.

Please remember that **ALL** these questions must be attempted **without** the use of a calculator and that the pass mark for all Part-66 multiple-choice examinations is 75%!

1. Which one of the following types of cell has a nominal output voltage of 2 V?

- (a) alkaline cell
- (b) lead-acid cell
- (c) nickel-cadmium cell.

2. Which one of the following statements is true?

- (a) only primary cells can be recharged
- (b) only secondary cells can be recharged
- (c) both primary and secondary cells can be recharged.

3. How many 1.2V cells must be connected in series to produce a battery with a nominal output of 24 V?

- (a) 10
- (b) 20
- (c) 24.

4. A secondary cell produces electricity from:

- (a) heat
- (b) light
- (c) chemical action.

5. The e.m.f. produced by a fresh zinc-carbon battery is approximately:

- (a) 1.2V
- (b) 1.5V
- (c) 2V.

6. A thermocouple produces electricity from:

- (a) heat
- (b) light
- (c) chemical action.

7. Which one of the following types of cell is rechargeable?

- (a) alkaline cell
- (b) lead-acid cell
- (c) zinc carbon cell.

Revision questions



8. A junction between two dissimilar metals that produces a small voltage when a temperature difference exists between it and a reference junction is known as:
- (a) a diode
 - (b) a thermistor
 - (c) a thermocouple.
9. A photocell consists of:
- (a) two interacting layers of a semiconductor material
 - (b) two electrodes separated by an electrolyte
 - (c) a junction of two dissimilar metals.
10. The materials used in a typical thermocouple are:
- (a) silicon and selenium
 - (b) silicon and germanium
 - (c) iron and constantan.
11. The relationship between voltage, V , current, I , and resistance, R , for a resistor is:
- (a) $V = IR$
 - (b) $V = I/R$
 - (c) $V = IR^2$
12. A potential difference of 7.5V appears across a 15Ω resistor. Which one of the following gives the current flowing in the resistor?
- (a) 0.25A
 - (b) 0.5A
 - (c) 2A
13. Three 6V batteries are connected in series. If the series combination delivers 2A to a load, which one of the following gives the resistance of the load?
- (a) 9Ω
 - (b) 12Ω
 - (c) 90Ω.
14. When two batteries are connected in parallel the load current is:
- (a) doubled in each battery
 - (b) shared between the two batteries
 - (c) the same as the current in each battery.
15. When the intensity of light falling on a photocell increases the current that it produces will:
- (a) increase
 - (b) decrease
 - (c) remain the same.

Answers are given at the end of the module.

About this course

Introduction

This workbook is intended to reinforce the learning that takes place in the classroom or lecture room. It provides a series of practical activities and investigations that complement syllabus sections 3.3 to 3.6 of EASA Part-66 Module 3, Electrical Fundamentals.

Locktronics equipment makes it simple and quick to construct and investigate electrical circuits. The end result can look exactly like the circuit diagram, thanks to the symbols printed on each component carrier.

Aim

The workbook aims to introduce students to the basic underpinning principles and concepts of aircraft electrical and electronic equipment. It also provides a useful introduction to electrical measurements and the use of ammeters and voltmeters.

Prior Knowledge

Students should have previously studied (or should be concurrently studying) Module 1 (Mathematics) and Module 2 (Physics) or should have equivalent knowledge at Level 2.

Learning Objectives

On successful completion of this course the student will have learned:

- to distinguish between primary and secondary cells;
- to distinguish between series and parallel connection of cells to form a battery;
- the basic characteristics of common types of cell;
- the thermoelectric principle and basic operation of thermocouples;
- the concept of photovoltaic conversion and basic operation of photocells;
- to recognise a series connection and recall its properties;
- to recognise a parallel connection and recall its properties;
- the effect of resistance on the size of the current flowing;
- that resistance is measured in ohms;
- how to use the resistor colour code to identify resistor values;
- how to use a multimeter to measure current, voltage and resistance;
- to recall and use the formulae derived from Ohm's Law;
- how to apply Ohm's Law to solve simple problems.

What students will need:

To complete this course, students will have access to the Locktronic parts and equipment listed opposite:

Note that the Aircraft Maintenance Kit contains many other parts that are used in the other workbooks that together cover aspects of Module 3 and 4.

Students will also need:

- either two multimeters, such as the LK1110, capable of measuring currents in the range 0 to 100mA, and voltages in the range 0 to 15V;
- or an ammeter with a range of 0 to 100mA, and a voltmeter with a range 0 to 15V.

For other modules in the series, they will need:

- a function generator, such as the LK8990, or equivalent;
- and an oscilloscope capable of monitoring the signals it produces, such as the LK6730 Pico 4000 virtual oscilloscope.

If you are missing any components, or need additional items, please contact Matrix or your local dealer.

Power source:

The larger baseboard is appropriate for use with this power supply, which can be adjusted to output voltages of either 3 V, 4.5 V, 6 V, 7.5 V, 9 V or 13.5 V, with currents typically up to 1 A. The voltage is changed by turning the selector dial just above the earth pin until the arrow points to the required voltage.

The instructor may decide to make any adjustment necessary to the power supply voltage, or may allow students to make those changes.

Each exercise includes a recommended voltage for that particular circuit.

Code	Description	Qty
LK2340	AC voltage source carrier	1
LK2347	MES bulb, 6V, 0.04A	3
LK2350	MES bulb, 6.5V, 0.3A	3
LK4025	Resistor, 10 ohm, 1W 5% (DIN)	1
LK4065	Resistor, 47 ohm, 1/2W, 5% (DIN)	1
LK4100	Resistor, 12 ohm, 1W, 5% (DIN)	1
LK4102	Motor, 6V, open frame	1
LK4123	Transformer, 2:1 turns ratio	1
LK5202	Resistor, 1k, 1/4W, 5% (DIN)	1
LK5203	Resistor, 10k, 1/4W, 5% (DIN)	2
LK5205	Resistor, 270 ohm, 1/2W, 5% (DIN)	1
LK5208	Potentiometer, 250 ohm (DIN)	1
LK5209	Resistor, 5.6k, 1/4W, 5% (DIN)	1
LK5221	Capacitor, 10 uF, Electrolytic, 25V	3
LK5250	Connecting Link	14
LK5291	Lampholder, MES	3
LK5607	Lead - yellow - 500mm, 4mm to 4mm stackable	2
LK5609	Lead - blue - 500mm, 4mm to 4mm stackable	2
LK6205	Capacitor, 1 uF, Polyester	1
LK6206	Capacitor, 4.7uF, electrolytic, 25V	2
LK6207	Switch, push to make, metal strip	1
LK6209	Switch, on/off, metal strip	1
LK6211	Resistor, 22k, 1/4W, 5% (DIN)	1
LK6213	Resistor, 15k, 1/4W, 5% (DIN)	1
LK6214R1	Choke, 10mH	3
LK6214R2	Choke, 47mH	1
LK6214R3	Choke, 5mH	1
LK6217	Capacitor, 2.2 uF, Polyester	2
LK6218	Resistor, 2.2k, 1/4W, 5% (DIN)	1
LK6482	Left hand motor rule apparatus	1
LK7409	AA battery holder carrier	3
LK7483	1:1 transformer with retractable ferrite core	1
LK7485	Alnico Rod Magnet	1
LK7487	Lenz's law kit	1
LK7489	Faraday's law kit	1
LK7746	Solar cell	1
LK7936	Fuse/universal component carrier	1
LK8275	Power supply carrier with battery symbol	2
LK8900	7 x 5 metric baseboard with 4mm pillars	1
LK8988	Thermocouple and carrier	1
LK9381	Ammeter, 0mA to 100mA	1



p25b

Using this course:

It is expected that the worksheets are printed / photocopied, preferably in colour, for the students' use. Students should retain their own copy of the entire workbook.

Worksheets usually contain:

- an introduction to the topic under investigation and its aircraft application;
- step-by-step instructions for the practical investigation that follows;
- a section headed 'So What?' which aims both to challenge learners by questioning their understanding of a topic and also provides a useful summary of what has been learned. It can be used to develop ideas and as a trigger for class discussion.
- a section headed 'For Your Records' which provides important summary information that students should retain for future reference.

This format encourages self-study, with students working at a rate that suits their ability. It is for the tutor to monitor that students' understanding is keeping pace with their progress through the worksheets and to provide additional work that will challenge brighter learners. One way to do this is to 'sign off' each worksheet, as a student completes it, and in the process have a brief chat with the learner to assess their grasp of the ideas involved in the exercises that it contains.

Finally, a set of examination 'Revision Questions' has been provided to conclude the work on each topic. These questions are of varying difficulty and are typical of those that students will face when they sit their Module 3 CAA examinations. It is recommended that students should attempt these questions under examination conditions and without the use of notes or calculators.

Time:

It will take most students between four and six hours to complete the full set of worksheets. It is expected that a similar length of time will be needed to support the learning in a class, tutorial or self-study environment.

Worksheet	Notes for the Tutor	Timing
<p>The first three worksheets are included for revision purposes. For some students, it may have been a considerable time since they studied electrical circuits.</p> <p>At the instructor's discretion, students can work through these worksheets to remind them about some essential aspects of electrical theory:</p> <ul style="list-style-type: none"> • the distinctive properties of series and parallel circuits; • the nature of electric current and 'voltage'; • the use of a multimeter to measure current and voltage. <p>Students who are already familiar with these topics may prefer to start at worksheet 4.</p>		
1	<p>Students need to distinguish between series and parallel connected circuits and understand the properties of voltages and currents in them.</p> <p>To keep things simple, the series and parallel-connected loads used in this investigation are represented by identically rated lamps (each is rated at 6 V, 0.04 A). Students need to be reminded that the brighter the bulb the greater will be the current flowing in it. By this means they should be able to make inferences based on the relative brightness of the light bulbs present in a circuit.</p> <p>The practical investigation involves setting up several series and series-parallel circuits. Students are also given a simple single-pole single-throw switch in order to control the circuit. Tutors may wish to ask individual students to present their solutions to the challenge question and then use this as a discussion with the rest of the class.</p>	30 - 45 minutes
2	<p>Now we move on from using the brightness of a bulb as a measure of current to the use of an ammeter. Tutors may prefer to use discrete meters rather than multimeters for this and subsequent worksheets.</p> <p>Multimeters are in widespread use because of their low cost and versatility. Although they differ in terms of the functions they offer and the precise details of their structure, the broad principles are the same. Here we look at their use to measure current (ammeter function) and later to measure voltage (voltmeter function.)</p> <p>We address the distinction between DC ranges and AC ranges, without going into detail about DC and AC.</p> <p>Beware! It is common to find that the ammeter settings are protected by an internal fuse. This is frequently 'blown' because students switch on the multimeter, connected as a voltmeter, with the dial turned to a current range. Instructors should check all fuses prior to this exercise, and be prepared with a supply of replacement fuses!</p> <p>The aim of the exercises is to spot the pattern for current flow in a circuit, that the total current leaving any junction in the circuit is equal to the total current entering the junction. (Compare this with traffic at a road junction, where crashes and parking can lead to a different result.)</p> <p>The worksheet ends with a close exercise and questions requiring students to apply the current rule discovered in the exercise.</p>	30 - 45 minutes

Worksheet	Notes for the Tutor	Timing
3	<p>This worksheet mirrors the structure of the last one, but looks at measuring voltage.</p> <p>The point is made in the introduction, that it is relatively easy to visualise an electric current - millions of electrons slowly squeezing their way along a wire, like crowds of people in a shopping mall, but that it more difficult to visualise voltage.</p> <p>For the present, the exercise concentrates on measuring voltage, rather than defining it. Students use a multimeter for this, by connecting it in parallel with the section of the circuit under investigation.</p> <p>The circuit diagram at the top of the second page of the worksheet shows three voltmeters. Each student does not need three multimeters, but can move one from one voltmeter position to the next to take the three readings.</p> <p>Again, students are asked to look for a pattern in their results. Ideally they see that the total of the voltmeter readings in any loop of the circuit is equal to the power supply, or battery, voltage.</p> <p>The worksheet ends with a close exercise and questions requiring students to apply the voltage rule from the exercise.</p>	25 - 40 minutes
4	<p>Introductory brainstorming/discussion/trigger questions could cover:</p> <ul style="list-style-type: none"> • Where is electrical power used in an aircraft? • From where does the electrical power come? • Why is more than one source of electrical power required? <p>In this worksheet, we investigate the series and parallel connection of cells in order to produce batteries. Students should first be introduced to the different types of cell and the distinction between primary and secondary types should be made clear. It is also important for students to know the basic characteristics of several of the most common types of cell, including lead-acid, alkaline, nickel-cadmium and zinc-carbon types.</p> <p>Series and parallel connection of batteries should be described together with representative circuit diagrams. Students need to be aware that the same load current flows through all of the cells in a series-connected battery but is shared between the cells in the case of a parallel-connected battery.</p> <p>Students are asked to construct three arrangements of series-connected cells and three arrangements of parallel-connected cells. By comparing the measured indications of voltage they should be able to confirm what they have previously learned about the series and parallel combination of individual cells.</p>	30 - 45 minutes

Worksheet	Notes for the Tutor	Timing
5	<p>Students need to be aware that electric current can be generated by several other methods, including thermocouples and photovoltaic cells (i.e. photocells). Later they will move on to investigate simple DC generators but, for now, we shall just concentrate on these two methods and how they might be used in an aircraft context.</p> <p>Students should be introduced to several common types of thermocouple and their basic characteristics (output voltage and temperature range). The worksheet mentions the thermoelectric effect - that an emf is generated when the two junctions between dissimilar metals are at different temperatures. Using a thermocouple probe has the advantage of reliable performance and robustness, but disguises the exact location of the two junctions. The instructor should point out that in this situation the second junction is at ambient temperature, whereas, for calibration purposes, it would be at 0°C.</p> <p>Typical aircraft applications should be discussed (e.g. exhaust gas temperature measurement). Students also need to be aware of the limitations of these devices—including non-linearity and the need for compensated leads where accurate indications are required.</p> <p>The practical investigation involves measurement of thermoelectric emf over a fairly small range of temperatures. This is carried out by immersing the thermocouple probe into a beaker of warm water together with a conventional mercury-in-glass or a digital thermometer (students will need to be reminded of the safety precautions if handling mercury thermometers, and also when using hot water obtained from an electric kettle).</p> <p>They should record their measurements of thermoelectric emf in a table with sufficient readings in order to be able to plot a graph showing how emf varies over the temperature range under investigation. Students should then determine the change in emf over the full range of temperature (extrapolating back to 0°C and, by dividing this by 80. Where possible, learners should be given the opportunity of examining and investigating an aircraft thermocouple probe unit.</p>	30 - 45 minutes
6	<p>Students should be introduced to the photovoltaic principle and basic characteristics and operation of photocells.</p> <p>The practical investigation involves measurement of photovoltaic e.m.f over a fairly small range of different light levels. This is carried out by placing the photocell in the full sunlight, partial shade, normal room lighting, and in total darkness.</p> <p>Students should record their measurements of photovoltaic emf and then compare their results with those of other learners. Where possible, students should be given the opportunity of examining and investigating a practical photovoltaic cell array (such as those used in remote ground-based applications).</p>	20 - 30 minutes

Worksheet	Notes for the Tutor	Timing
7	<p>This worksheet focuses on the popular examination topic of Ohm's Law. It introduces the use of a potentiometer as a variable voltage supply. Students might need help in setting up the circuit, though a picture is provided to assist with this.</p> <p>The instructions refer to an ammeter and a voltmeter, but while it is possible to use a single multimeter to do both jobs, it makes it much easier if the student has access to two multimeters. If using only one, once the current is measured, a connecting link must replace the ammeter, while the multimeter is acting as a voltmeter.</p> <p>The voltage adjustment is delicate, and students should be encouraged to have patience when setting it to the values given in the table.</p> <p>Ohm's Law actually applies only when a very specific, and unrealistic, set of circumstances apply. In particular, the temperature of the conductor (a resistor in this case) must not change. As the current through it increases, the resistor gets hot! We attempt to limit this by specifying a maximum of 0.9V across the resistor. The students plot a graph of their results, and can use it to obtain a value for the resistance of the resistor.</p> <p>The next section introduces the resistor colour code. Tutors may want to spend time giving further examples of its use.</p> <p>A guide on using a multimeter to measure resistance follows,. The most important aspect of this is that this cannot be done 'in-circuit'. The component must be removed from the circuit for the measurement.</p> <p>The worksheet ends with questions on using the Ohm's Law formulae, and on applying the colour code.</p>	25 - 40 minutes

Worksheet 1

1. 20
2. 90 A
3. 12 V
4. 27 A

Worksheet 3

1. 24 / (cell e.m.f. measured in bright sunlight)
2. 200 cells in a series bank produces 120 V at 0.5 A
20 series banks (each of 200 cells) produces 120 V at 10 A
Each battery will require a total of $200 \times 20 = 4,000$ individual cells.

Worksheet 7

100 k Ω ; 5.6 k Ω ; 82 Ω

Revision question paper

1. (b)
2. (b)
3. (b)
4. (c)
5. (b)
6. (a)
7. (b)
8. (c)
9. (a)
10. (c)
11. (a)
12. (b)
13. (a)
14. (b)
15. (a)

31 07 23 Reformatted to new style