

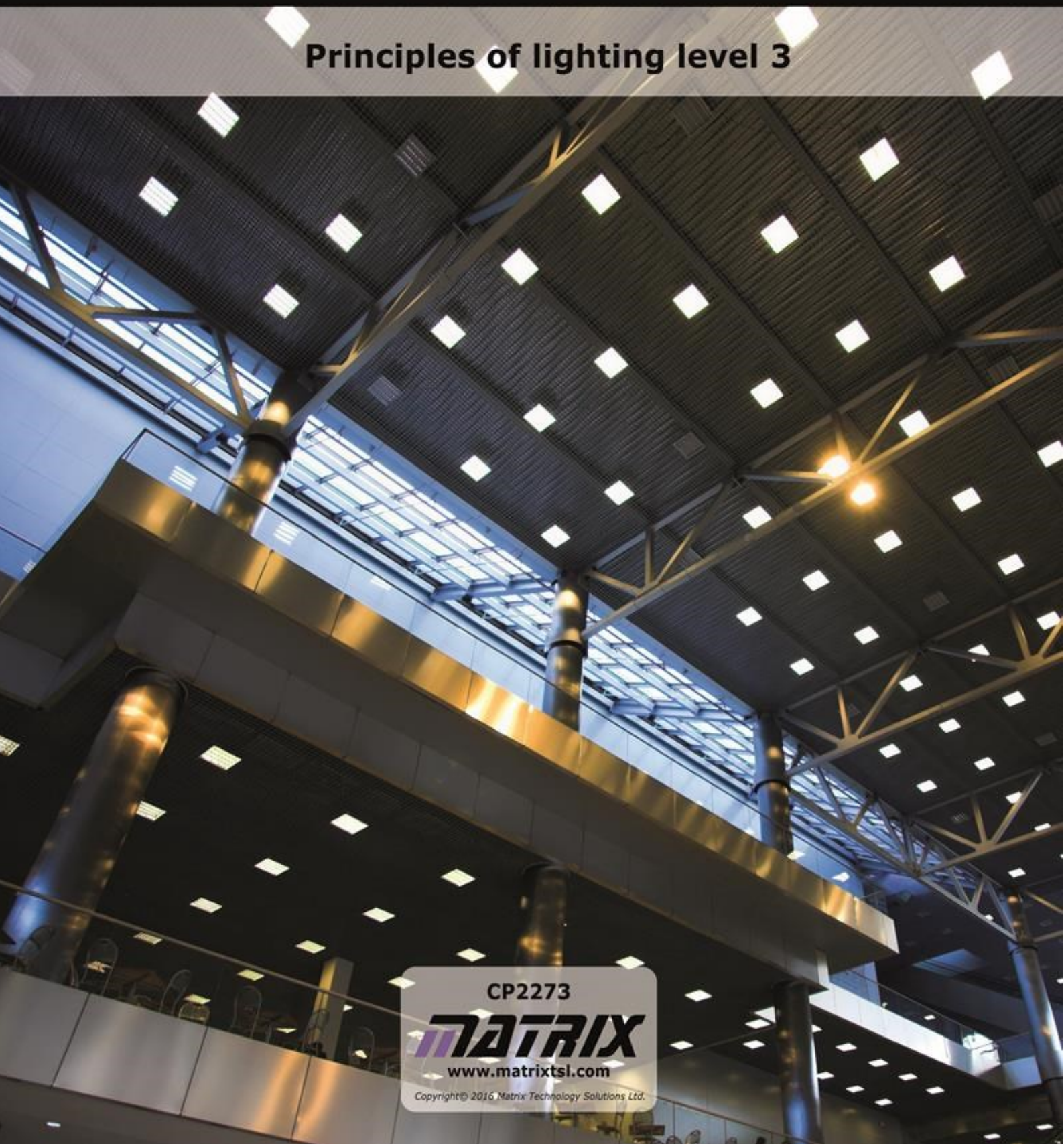

Simplifying Electricity

Principles of lighting level 3



CP2273

MATRIX

www.matrixtsl.com

Copyright © 2016 Matrix Technology Solutions Ltd.

Introduction	3
Worksheet 1 - Measuring light	7
Worksheet 2 - Energy efficiency	8
Worksheet 3 - The effect of distance	9
Worksheet 4 - The effect of angle	10
Worksheet 5 - The effect of reflectors	12
Worksheet 6 - Challenge 1	13
Worksheet 7 - Challenge 2	14
Appendix	15
Student Handbook	19
Instructor Guide	31

Why is good lighting important?

Lighting is important to the health and safety of people using the area.

Poor lighting causes effects like eyestrain, migraine and headaches, increasing absence through sickness and reducing productivity.

Good lighting allows people to spot and avoid hazards.

The task - to light a given room to the required level, by determining:

- how many luminaires (electric lights) are required ;
- of what power rating;
- and positioned where.

It is not simply a matter of asking “How bright is a light bulb?” That is rather like asking “how long is a piece of string?”

It depends...

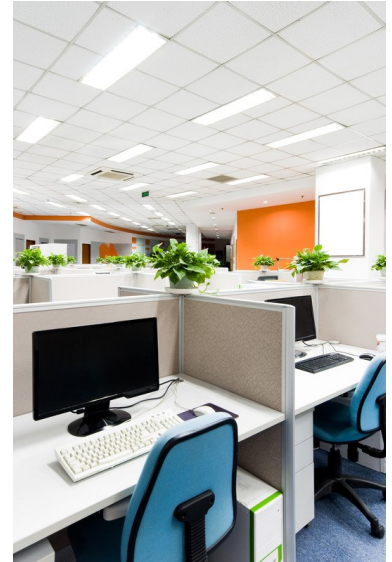

The solution involves consideration of issues like:

- **Energy efficiency;**
 - **Spectral response;**
 - **Dimensions** of the room;
 - **Activities** that take place in the room.
- **Energy efficiency** - how much of the electrical energy supplied to the luminaire goes into generating light.
(More precisely, the issue is the **luminous efficacy** of the luminaire - how much of the energy supplied goes in to generating **visible** light.)

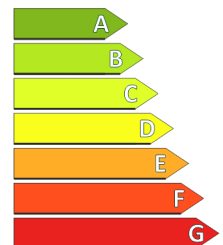

This depends on the type of luminaire used. The table gives typical values:

Technology	Luminous efficacy in lumen/watt
Filament incandescent	5 - 10
Halogen incandescent	10 - 20
Compact fluorescent	45 - 70
Linear fluorescent	50 - 100
LED	80 - 150

Introduction

As the table shows, luminaires use one of three common types of light source.

Some, known as **incandescent sources**, rely on heating up material until it gets so hot it glows. The colour of the light produced depends on the temperature of the material.



Fluorescent lights generate ultraviolet radiation initially - invisible to us. However, this is absorbed by a coating on the inside of the lamp which then re-transmits visible light.

The precise colour depends on the substances in the coating.

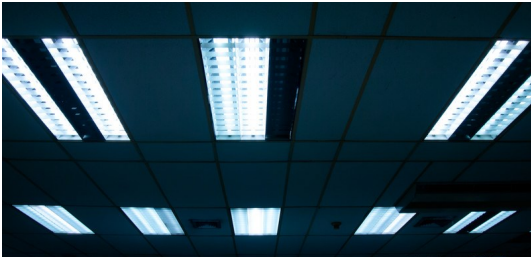

LED lights involve more complex physics, beyond the scope of this course. They generate light without the need for high temperature by passing electric current through semiconductor crystals. The colour of the light produced depends on the chemical composition of the semiconductor crystals. They are used to display data as well as to provide general lighting.



- **Spectral response**

- how much of the energy is in the visible part of the spectrum.

The diagram illustrates what we mean by the visible spectrum.

It means the colours of light that our eyes respond to - we see green light the best!

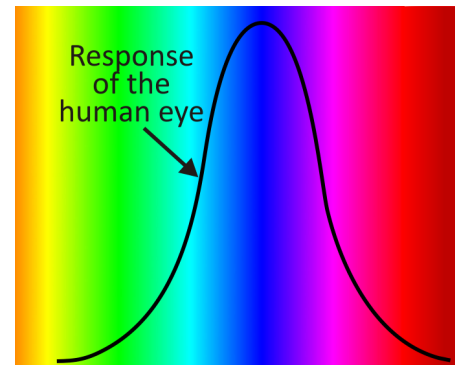

- **Dimensions** of the room

- the higher the ceiling, the further the light from a particular luminaire spreads out and the weaker it gets.

Activity	Typical location	Average illuminance in lux
General movement	Entrances and corridors	20
Movement in hazardous areas	Construction sites, Loading bays	50
Work requiring low level of detail	Kitchens, General factory work	100
Work requiring medium level of detail	Offices and workshops	200
Work requiring fine detail	Drawing offices, Small components assembly line	500

- **Activities** that take place in the room -

The table lists recommended lighting levels, in lux, for a number of different situations.

We have used some concepts and units that may be unfamiliar.

Here is a glossary:

The concepts:

- **Flux** - something that flows.
- **Radiant flux** - energy that flows in the form of electromagnetic radiation.
- **Luminous flux** - energy that flows as light, i.e. produces the sensation of sight in our eyes. Often used as an objective measure of the "useable" light emitted from a source, it is measured in lumens.
- **Illuminance** - the total luminous flux hitting (illuminating) a unit of surface area. It is a measure of how much 'useable' light strikes a surface. Illuminance is measured in lux or lumens per square metre.
- **Luminance** - measures the amount of light reflected off a surface - the 'brightness' of an object. Luminance is measured in candelas per square metre.

The units:

- **Lumen (lm)**: measures how much light the source produces - the **total** amount of light energy, regardless of direction. It is used to measure energy efficiency, using a lumens-per-watt formula. In the lighting industry the result is called 'luminous efficacy'.
- **Lux (lx)**: equals one lumen per square metre. Used in conjunction with distance, it allows us to calculate whether a luminaire delivers adequate light intensity for specific applications.
- **Candela (cd)**: shows how well a light source enables humans to see objects. It measures how well the light produced stimulates our vision. Whereas the **radiant intensity** measures the total energy radiated in the full visible spectrum, the candela looks at how much energy is emitted at the peak response frequency, 540×10^{12} Hz, green light. It is not the same measure as the lumen however, as it does not indicate the total light energy but how bright the source appears. A laser, for example, is highly focused into a very narrow beam and will have a low lumen value, as the total light energy given off (in all directions) is small. However, it will have a very high 'brightness', in candela.

Worksheet 1

Measuring light

Light meters are present in a wide range of applications. Some are embedded in cameras, allowing them to set exposure times automatically.

Some allow cars to turn on headlights automatically when it gets dark. Some control street lighting, security lights or domestic lamps. The one included with the equipment for this module indicates the light intensity in lux (lumen / square metre.)



Over to you:

- Examine the light meter. Notice the external light sensor and the control dial. Usually, when taking readings, the sensor is turned so that light hits it vertically. The display shows the number '1' when the light intensity is too bright for the range chosen. Turn the dial clockwise until a proper reading is shown.



- Move around taking light measurements as you go. Complete the table given in the Student Handbook, reproduced below to help you.

Location	Light level in lux
Outdoors - bright sunshine	
Outdoors - shade	
Room - near window	
Room - near luminaire	
Room - shade	
Room - dark corner	

- Compare your readings with those given in the table on page 5. Are the locations you tested suitable for any of these kinds of activity? Answer the questions in the Student Handbook.

Worksheet 2

Energy efficiency

Electrical energy costs money!

Why waste it heating the surroundings when what you really want is a light source!

This investigation looks at whether LED lighting is more energy efficient than an incandescent light.

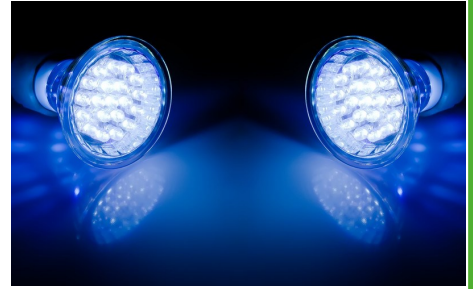

Over to you:

- Build the circuit shown opposite, using the LED lamp.
- A possible layout is shown at the bottom of the page.
- Connect the 12V DC power supply and switch it on.
- Close switch **S**.

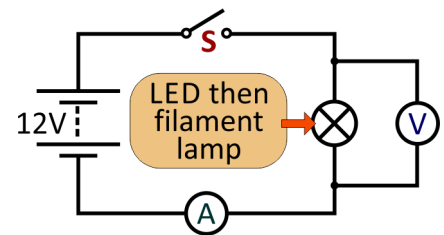

The LED bulbs are extremely bright.

Do not stare at them for long periods of time!

- Hold the LED lamp in between finger and thumb. Do you detect any rise in temperature?
- Measure the current through the LED lamp and the voltage across it.
- Hold the meter's light sensor 10cm above the lamp and measure the light intensity from the lamp.
- Record them in the table given in the Student Handbook, reproduced below to help you.
- Now, swap the LED lamp for the 12V filament lamp and repeat the procedure.
- Once again, record the measurements in the Student Handbook.
- Complete the calculations using these measurements and answer the questions.

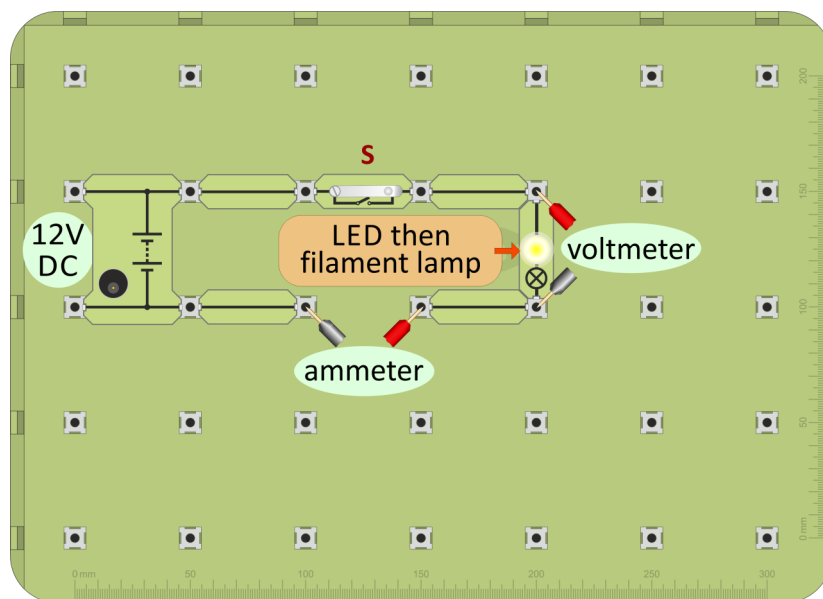

Worksheet 3

The effect of distance

The Sun is pretty bright when we see it at its best, and we are 150 million kilometres away!

How bright would it appear from the surface of Mercury (only 40% of that distance from the Sun) or from Jupiter, over five times as far away from the Sun?

The results of this next investigation will help to answer these questions.



Over to you:

This investigation is best carried out in subdued lighting, in a room with drawn blinds, or even under a bench. It uses the pillars on the baseboards as indicators of distance from the light source: they are spaced 50mm apart.

- Build the circuit shown below and switch on the power supply.
- Place the light sensor so that it rests up against the pillars at distance '1' from the light source. Twist the sensor a little and notice the maximum reading obtained.
- Record this reading in the table in the Student Handbook.
- Repeat this procedure with the light sensor at the other positions shown in the layout below. Each time, record the light intensity in the Student handbook table.

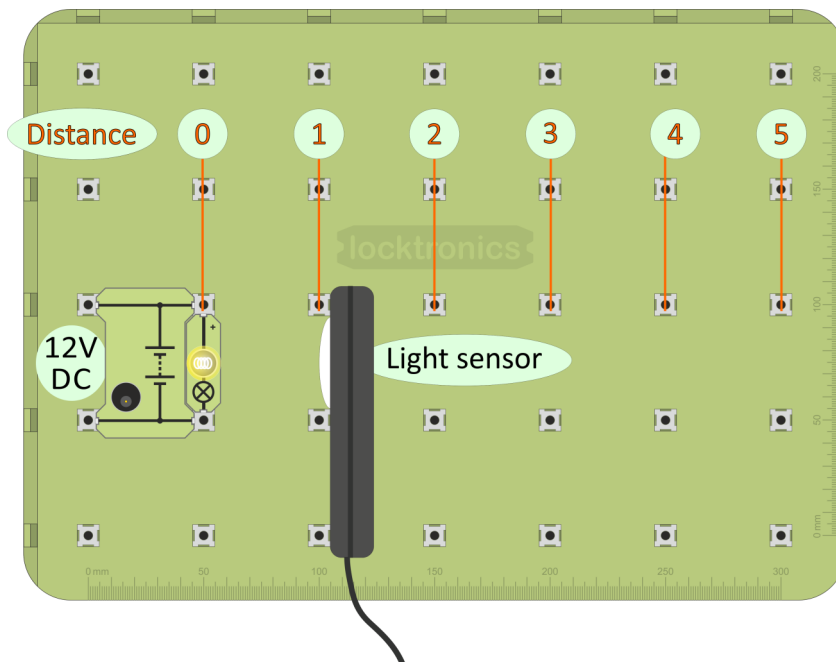

Worksheet 4

The effect of angle

Even on a hot, sunny summer day, the temperature starts to drop as the sun sinks in the sky. It is not further from the earth. It has not cooled down. Light from it spreads over a larger area and so has a smaller warming effect.

For places on the equator, the sun is directly overhead at mid-day no matter what time of year. As a result, there is little variation between seasons.

Photovoltaic solar panels produce maximum output when the sun is directly above them.

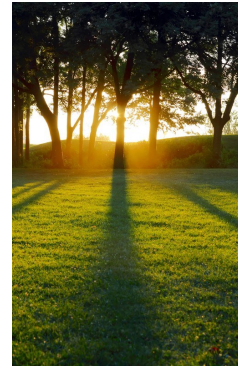

Over to you:

This investigation is also best carried out in subdued lighting.

It uses a sheet of paper on which are printed lines at angles of 0° , 30° and 60° and a guide line for the position of the baseboard.

On the light sensor, the seam between the front and back mouldings is used to set the direction in which it is facing.

- Build the circuit shown below and switch on the power supply.
- Place the sheet of paper as shown, so that the base board sits on the dotted line and the centre line is aligned with the centre of the LED lamp.
- Place the light sensor so that it is vertical with the seam lined up with the 0° line. Twist the sensor a little and memorise the maximum reading obtained.
- Rotate the sensor until the seam lines up along the 30° line.
- Do the same for the 60° line.
- Record all readings in the Student Handbook.

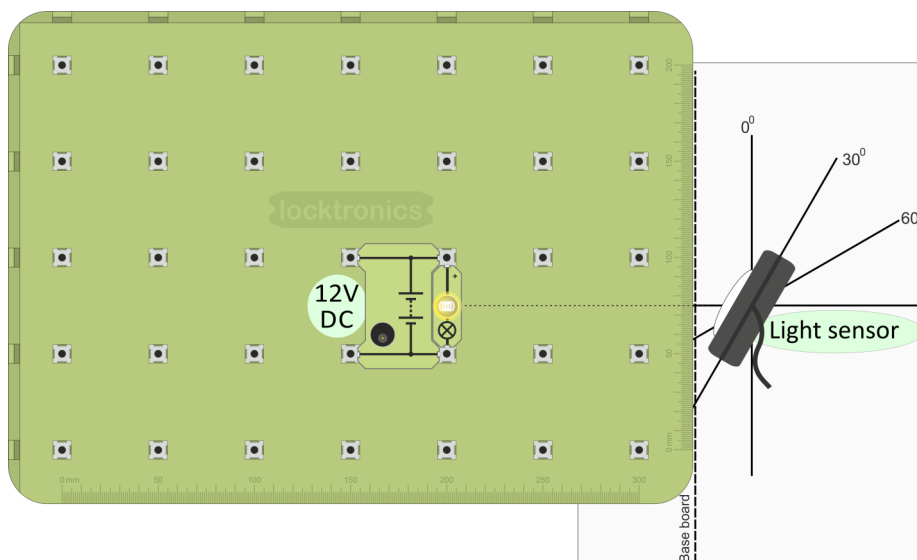
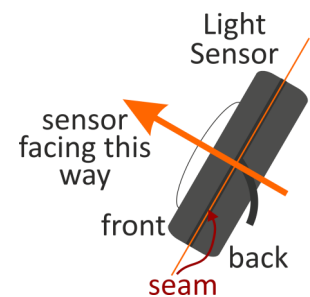

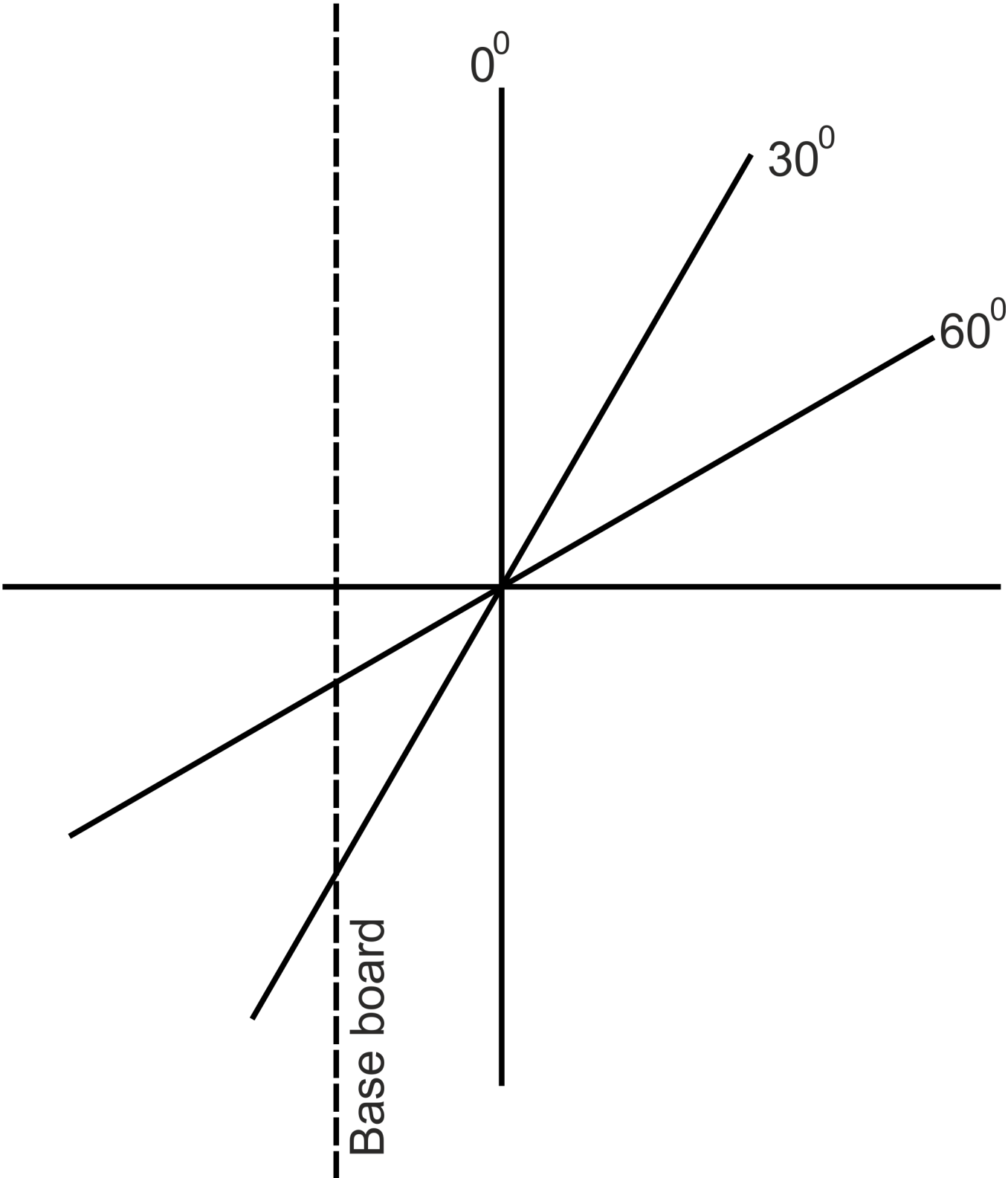

Worksheet 5

The effect of reflectors

Generating unwanted light is a waste of money!

The task - to direct the light to where it is needed and remove it from other areas.

Luminaires often use reflectors to modify the light distribution.

In some cases, this is to achieve a focussed beam.

In others, it is to achieve a spread of light over an extended work area.

This worksheet explores the effect of a reflector on the distribution and intensity of light from a LED lamp. The precise design of the investigation is left open to allow students to practice the skills involved in investigating a light installation.

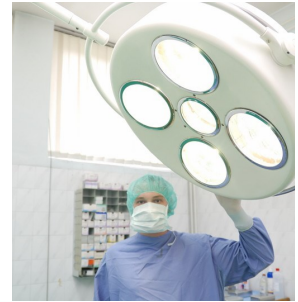

Over to you:

The challenge:

Investigate the spread of light from the LED lamp with the reflector in place and then without it.

This investigation is best carried out in subdued lighting.

The target area is along the line marked 'X Y' on the layout.

- Build the circuit shown below, with the LED lamp at the position shown and switch on the power supply.
- Place the light sensor at various positions along the line 'X Y' and measure the light intensity.
- Remove the reflector and repeat the procedure.
- Describe your findings in the Student Handbook.

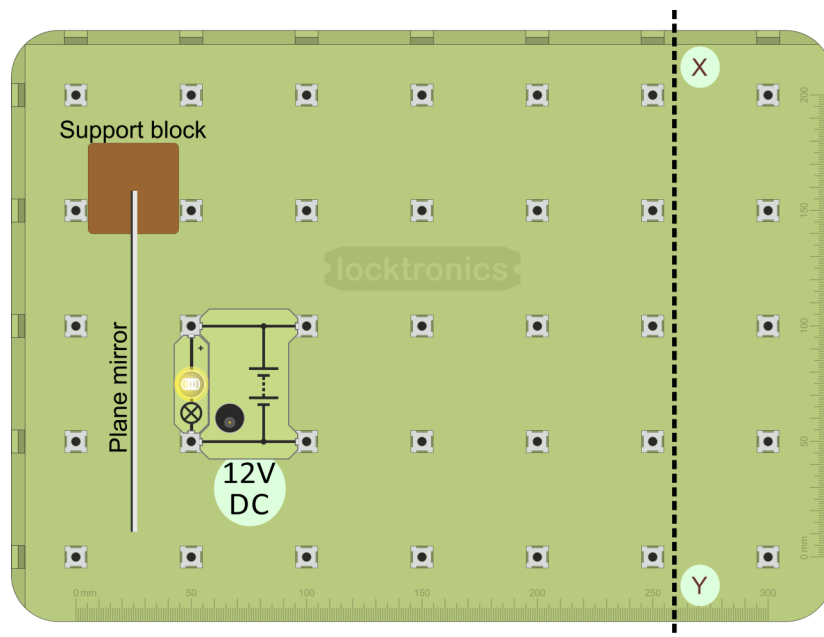

Worksheet 6

Challenge 1

A lighting engineer must be able to design an installation to provide the required level of illumination with the minimum of installation and running costs.

The design must take into account the height of the luminaires above the work surface and the activities that will take place, as the table on page 5 shows.



Over to you:

- Build the circuit shown below, with all sixteen LED lamps.
- Switch on the power supply.

The challenge:

Investigate the following questions:

- At what distance from the LED lamps does the intensity drop to 100 lux, adequate lighting for work involving a low level of detail?
- At that distance, over what area does the light intensity remain above 50 lux?
- Do twice the number of LED lamps produce twice the brightness?
- Describe your findings in the Student Handbook.

Notes:

- the investigations are best carried out in subdued lighting;
- take care not to short circuit the power supply;
- take care to ensure that each LED lamp receives the full 12V;
- to halve the number of LED lamps while retaining a relatively uniform beam, remove the ones that are marked with a red circle;
- it may be better to work 'upside-down' with the luminaire pointing up at the light sensor.

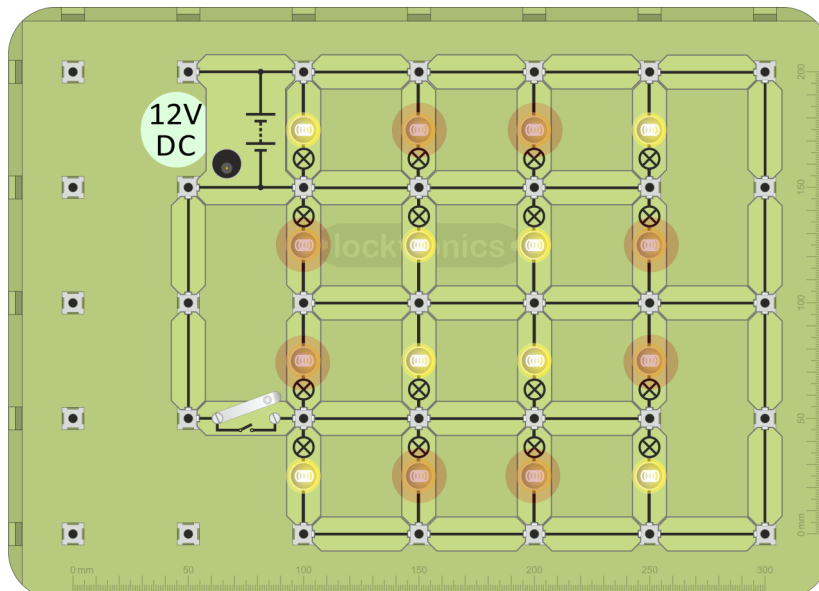

Worksheet 7

Challenge 2

The correct level of illumination and spread is an important element of health and safety.

The challenge here is to design and test a lighting installation for a factory workstation.



Over to you:

A workstation is used to solder printed circuit boards. It requires adequate lighting. Your task is to design that lighting.

The design brief:

A lighting installation must deliver a minimum of 750 lux over an area 50cm by 35cm at the work surface.

The luminaire is positioned at a height of 50cm above the work surface.

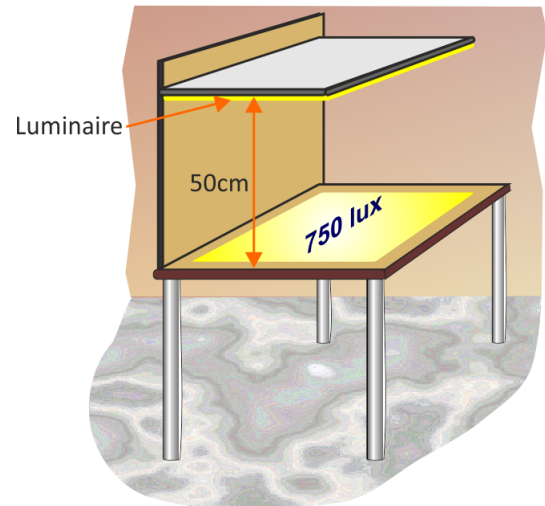

Notes:

test the design in subdued lighting

- a good design:
 - delivers the design brief;
 - using a minimum number of LED lamps, to cut down installation and running costs;
- take care not to short circuit the power supply;
- take care to ensure that each LED lamp receives the full 12V;
- the design should not use a reflector (though in real life, it probably would);
- it may be better to work 'upside-down' with the luminaire pointing up at the light sensor.

Use the template in the Student Handbook to show your design. Describe how you tested it and include the test results.

Illumination

Appendix

-

Electrical measurements with a multimeter



The picture shows one form of multimeter. It has a wide range of uses - which varies from model to model - but usually includes measuring AC and DC voltage and current.

When using a multimeter, before you switch it on:

- take care to plug the probes into the correct sockets;
- select the correct range.

(‘Auto-ranging’ versions select the best range automatically.)

Voltage:

- is a measure of the force pushing the electrons around the circuit;
- measures energy lost or gained as an electron moves through part of a circuit
- is measured with a voltmeter connected in parallel with the component.

The circuit symbol for a voltmeter is shown in the diagram.

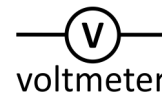

Using a multimeter to measure voltage:

Multimeters can measure both AC and DC.

The following symbols distinguish between them:

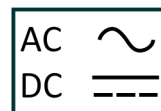

- Plug one wire into the black ‘COM’ socket.
- Plug another into the red ‘V’ socket.
- Select the 20V DC range by turning the dial to the ‘20’ mark next to the ‘V’ symbol.

(It is good practice to set the meter on a range that is much higher than  the reading you are expecting.

Then refine it by choosing a lower range to suit the voltage you find.)

- Plug the wires into the sockets at the ends of the component under investigation.
- Switch on the multimeter when you are ready to take a reading.
- A ‘-’ sign in front of the reading means that the meter wires are connected the wrong way round. Swap them over to get rid of it!





When using a multimeter to measure current, plug the probes into the '**A**' and '**COM**' sockets, or equivalents.

Then select the correct range, either from the '**A~**' section, for AC current or the '**A**' section, for DC current.

Finally, switch on. 

Current:

- measures the number of electrons passing any point in the circuit each second;
- measures the rate of flow of electrical charge in the circuit;
- is measured with an ammeter connected in series with the component.

The circuit symbol for an ammeter is shown in the diagram.

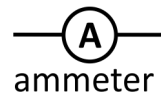

Using a multimeter to measure current:

- Plug one wire into the black '**COM**' socket.
- Plug another into the red '**mA**' socket.
- Select the 200mA DC range by turning the dial to the '**200m**' mark next to the  '**A**' symbol.

(Again, it is best to set the meter on a higher range to begin with. Then choose a lower range to suit the current you find.)

- Break the circuit where you want to measure the current, by removing a link, and then plug the two multimeter leads in its place.
- Switch on the multimeter when you are ready to take a reading.
- A possible problem:

The ammeter range is protected by a fuse located inside the body of the multimeter. This may have 'blown', in which case the ammeter will not work. Report any problems to your instructor so that it can be checked.



When using a multimeter to measure resistance, the component must be removed from the circuit first!

Once again, before you switch on:

- take care to plug the probes into the correct sockets, the ' Ω ' and '**COM**' sockets;
- select the correct range.

Resistance:

- is a hindrance to the flow of electrons around the circuit;
- removes energy from each electron as it moves through the resistor;
- converts this energy into heat;
- is measured in units called 'ohms' (symbol - ' Ω ') or kilohms ($k\Omega$), using an ohmmeter. (1 kilohm = 1 000 ohms.)

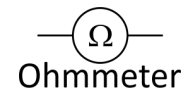

Using a multimeter to measure resistance:

- Plug one wire into the black '**COM**' socket.
- Plug another into the red ' Ω ' socket.
- Turn the dial to select a resistance range, such as 200k Ω .
(Once again, it is good practice to set the meter on a range higher than the reading you are expecting and then refine it to a lower range.)
- Make sure that the component under investigation is not connected to any other.
- Plug the wires into the sockets at the ends of the component.
- Switch on the multimeter when you are ready to take a reading.

Illumination

Student Handbook

-

For your records

Introduction

Lighting is important to the health and safety of people using the area.

Poor lighting causes effects like eyestrain, migraine and headaches, increasing absence through sickness and reducing productivity. Good lighting allows people to spot and avoid hazards.

The solution involves consideration of issues like:

- **Energy efficiency;**
- **Spectral response;**
- **Dimensions** of the workspace;
- **Activities** that take place in it.

Energy efficiency, (better called **luminous efficacy**,) measures how much of the electrical energy supplied goes into generating visible light. It depends on the type of luminaire used.

Technology	Luminous efficacy in lumen/watt
Filament incandescent	5 - 10
Halogen incandescent	10 - 20
Compact fluorescent	45 - 70
Linear fluorescent	50 - 100
LED	80 - 150

Incandescent lights rely on heating up material until it gets so hot that it glows. The colour of the light produced depends on the temperature of the material.

Fluorescent lights generate ultraviolet radiation initially - invisible to us. However, this is absorbed by a coating on the inside of the lamp which then re-transmits visible light. The precise colour depends on the substances in the coating.

LED lights involve more complex physics, beyond the scope of this course. They generate light without the need for high temperature by passing electric current through semiconductor crystals. The colour of the light produced depends on the chemical composition of the semiconductor crystals.

Spectral response, how much of the radiation produced is in the visible part of the spectrum, shows which colours of light our eyes respond to the best.

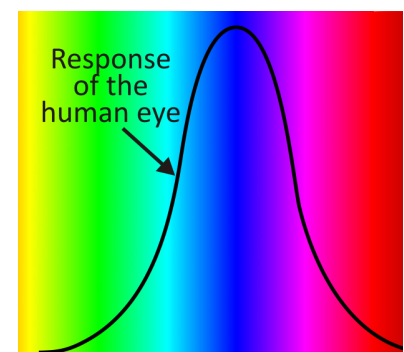

The answer is green light!

Dimensions - the higher the ceiling, the further the light from a particular luminaire spreads out and the weaker it gets.

Activities taking place -

Activity	Typical location	Average illuminance in lux
General movement	Entrances and corridors	20
Movement in hazardous areas	Construction sites, Loading bays	50
Work requiring low level of detail	Kitchens, General factory work	100
Work requiring medium level of detail	Offices and workshops	200
Work requiring fine detail	Drawing offices, Small components assembly line	500

Glossary:

- **Flux** - something that flows.
- **Radiant flux** - energy that flows in the form of electromagnetic radiation.
- **Luminous flux** - energy that flows as light, i.e. produces the sensation of sight in our eyes. A measure of the "useable" light emitted from a source, it is measured in **lumens**.
- **Illuminance** - the total luminous flux hitting (illuminating) a unit of surface area. It is a measure of how much 'useable' light strikes a surface and is measured in **lux**.
- **Luminance** - measures the amount of light reflected off a surface - the 'brightness' of an object. Luminance is measured in **candelas per square metre**.
- **Lumen:** measures the **total** amount of light energy regardless of direction. It is used to measure energy efficiency, using a 'lumens-per-watt' formula. The result is called '**luminous efficacy**'.
- **Lux:** equals one lumen per square metre. Used in conjunction with distance, it allows us to calculate whether a luminaire delivers adequate light intensity for specific applications.
- **Candela:** shows how well a light source enables humans to see objects. It measures how well the light produced stimulates our vision. Whereas the **radiant intensity** measures the total energy radiated in the full visible spectrum, the candela measures how much energy is emitted at the peak response frequency, 540×10^{12} Hz, green light.

Worksheet 1 - Measuring light

Here are the readings taken with the light meter:

Location	Light level in lux
Outdoors - bright sunshine	
Outdoors - shade	
Room - near window	
Room - near luminaire	
Room - shade	
Room - dark corner	

Use the table on page 5 to answer the following:

- Which location is suitable for doing detailed work?
- Which location is suitable for general factory work?

Worksheet 2 - Energy efficiency

A filament (incandescent) lamp and a LED lamp were set up to produce the same light output.

The following measurements were taken:

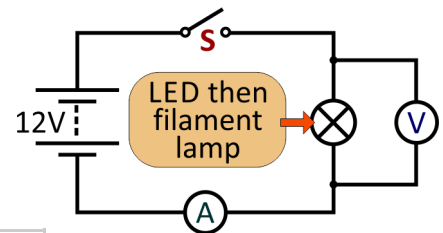

Light source	Light intensity in lux	Voltage in V	Current in mA
LED			
Filament			

Use these in the formula $P = I \times V$ to calculate:

- the power P_1 , dissipated in the incandescent lamp
- the power P_2 , dissipated in the LED lamp

Which bulb got hotter?

Comment on any differences in the light produced by the two sources:

.....

.....

.....

.....

Worksheet 3 - The effect of distance

The table shows how light intensity falls away with distance from the source.

Plot these results on the axes provided below and compare the resulting curve with the inverse square law behaviour.

Distance	Light level in lux
1	
2	
3	
4	
5	

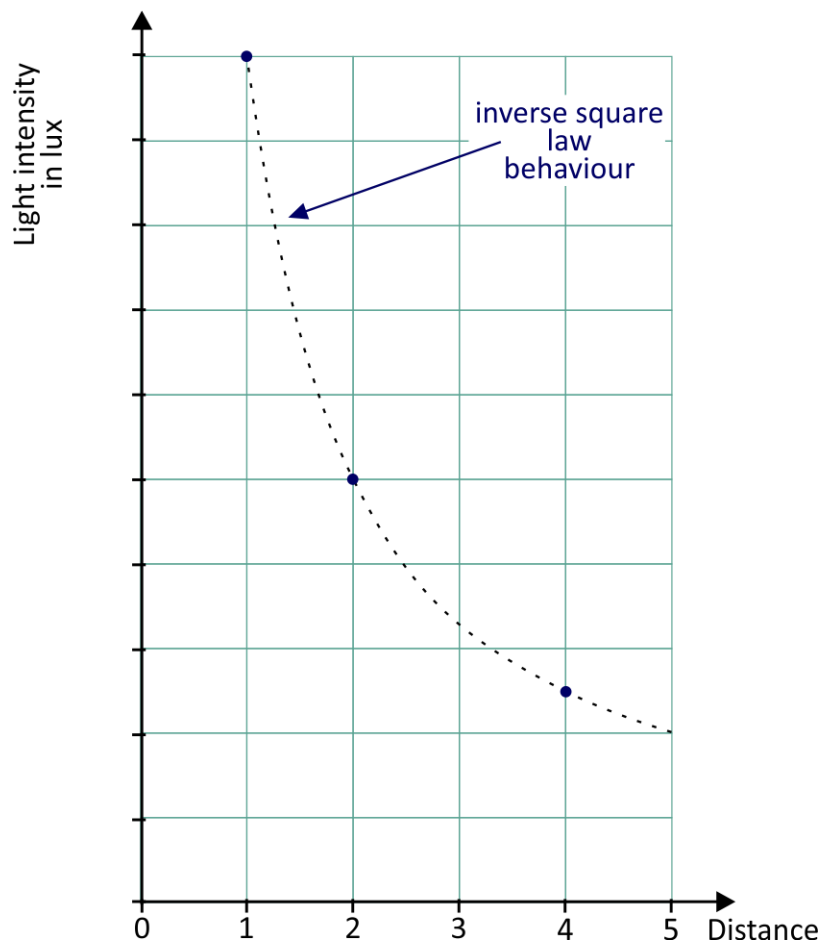

Worksheet 3 - The effect of distance - continued...

Inverse square law of illumination:

The Illuminance at point **P**, on a plane at right-angles to the line joining **P** and a point source of light depends on the **square** of the distance between them and gets smaller as the distance increases.

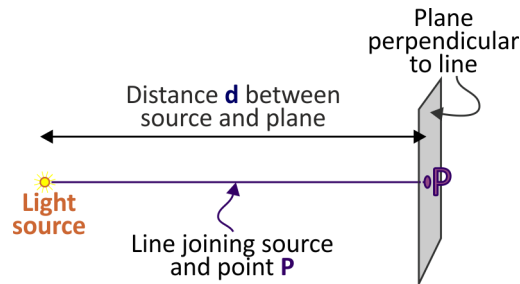

Mathematically:

Illuminance **E** depends on $1 / d^2$

This means that when **d** is:

- doubled (2 times bigger), **E** is four times ($= 2^2$) smaller;
- trebled (3 times bigger), **E** is nine times ($= 3^2$) smaller etc.
-

The result comes directly from geometry:

When the distance from the light source doubles, the beam is twice as high and twice as wide, giving it an area four times bigger. The light is now spread over an area four times bigger and so is four times less intense.

The following diagram illustrates this:

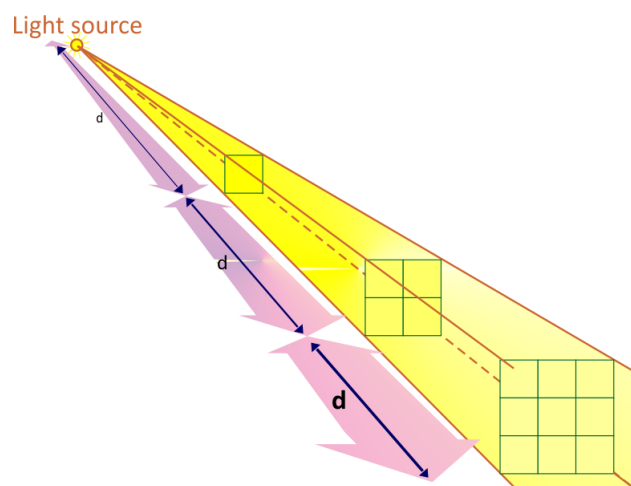

Despite appearances, all the squares in the diagram are the same size and the distances marked 'd' are equal!

Worksheet 4 - The effect of angle

Your measurements:

Angle X	Cosine of angle X	Intensity	Theoretical value
0	1		
30	0.87		
60	0.5		

Lambert's cosine law:

The illuminance at a point is proportional to the cosine of the angle of incidence of the light hitting the surface.

Complete the table by calculating the theoretical values from Lambert's cosine law, using the formula:

$$\text{Theoretical value} = \text{intensity at } 0^\circ \times \cos X$$

Compare your measurements with the theoretical values.

What are the sources of error in this experiment?

.....

.....

In optics, angles are usually measured from the 'normal' at the point where the light hits the plane. The normal is a line at right angles to the plane. This terminology is illustrated in the diagram.

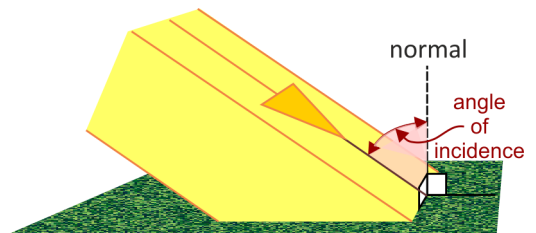

This law also results from the geometry of the situation. When a beam of light strikes a surface at a shallow angle, it spreads over a bigger area than when it hits it directly (when the angle of incidence = 0° .) The area over which it spreads depends on the angle of incidence, X .

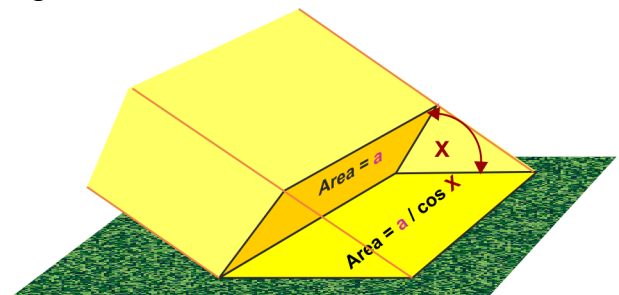

Where the light beam has a cross-sectional area a , the surface illuminated has an area equal to $a / \cos X$.

As a result, the light intensity drops by a factor of $\cos X$.

The next diagram shows the result of this. It uses the relationships:

- $\cos 0^\circ = 1$;
- $\cos 30^\circ = 0.87$;
- $\cos 60^\circ = 0.5$.

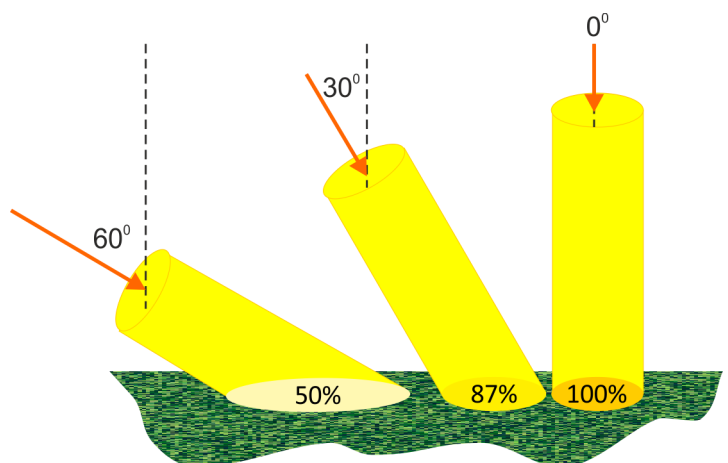

Worksheet 5 - The effect of reflectors

Your measurements:

Use the table to show the intensity of light at locations along the line 'X Y'.

With reflector	Without reflector

Describe the effect of adding a reflector.

.....

.....

.....

.....

.....

.....

.....



Worksheet 6 - Challenge 1

Question 1:

At what distance from the LED lamps does the intensity drop to 100 lux, adequate lighting for work involving a low level of detail?



Worksheet 6 - Challenge 1

Question 3:

Do twice the number of LED lamps produce twice the brightness?

.....
.....
.....
.....
.....
.....
.....
.....
.....
.....
.....
.....
.....
.....
.....
.....
.....
.....
.....
.....
.....

Worksheet 7 - Challenge 2

The design brief:

A lighting installation must deliver a minimum of 750 lux over an area 50cm by 35cm at the surface of a work station. The luminaire is positioned at a height of 50cm above the surface.

Your design:

Use the template to show your final design for the workstation lighting, using the symbols given in the key.

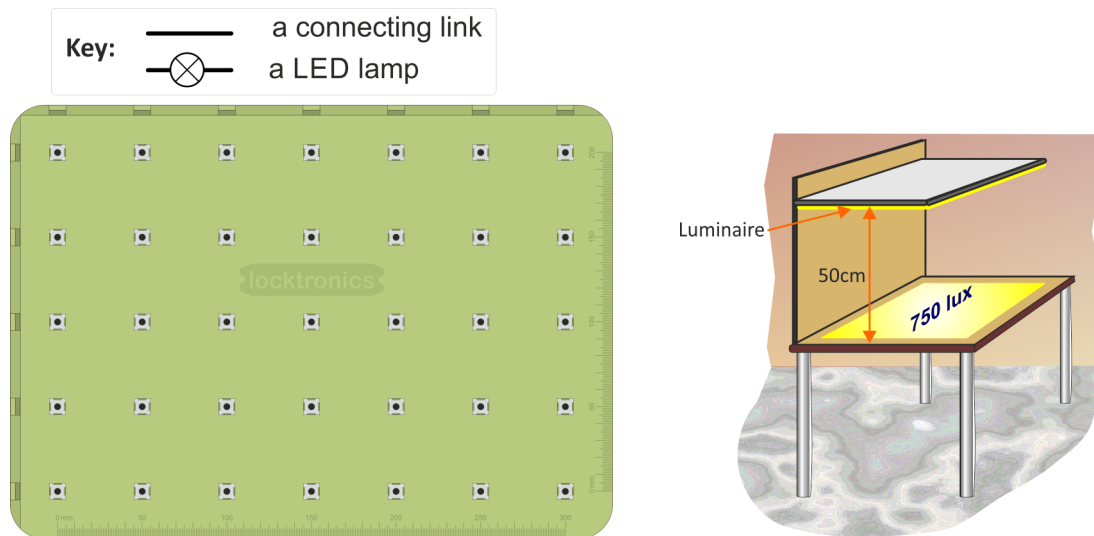

Describe how you tested your design:

.....

.....

.....

.....

.....

.....

.....

.....

.....

.....

.....

Give the results of your measurements:

.....

.....

.....

Illumination

Instructor Guide

About this course

Introduction

The course is essentially a practical one. Locktronics equipment makes it simple to construct and test electrical circuits. Where possible, practical implications and applications of the theory are highlighted to make the course more relevant to the students.

A Student Handbook is included to give students a concise record of their studies.

Aim

The course introduces students to concepts used in domestic and industrial electrical installation.

It covers much of the content of the City and Guilds Level 3 Advanced Technical Diploma in Electrical Installation, topic 4 - *Understand the principles and applications of electrical lighting systems.*

Prior Knowledge

It is recommended that students have followed the LK 4098 “Electrical wiring 1” course, or have equivalent knowledge and experience of building simple circuits, and using multimeters.

Learning Objectives

On successful completion of this course the student will be able to:

- list adverse effects of working in conditions of inadequate lighting;
- name four factors that must be considered when designing a lighting installation;
- explain the meaning of the term ‘energy efficiency’ applied to luminaires;
- describe the general features of incandescent, fluorescent and LED lighting;
- explain the meaning and significance of the term ‘spectral response’;
- explain why the dimensions of the room and the activities that take place in it affect the lighting design;
- distinguish between radiant flux and luminous flux;
- distinguish between luminance and illuminance;
- distinguish between the following units: lumen, lux and candela.
- use a light meter to measure illuminance;
- carry out an experiment to compare the energy efficiency of two low voltage light sources;
- use the formula ‘ $P = I \times V$ ’ to calculate the power dissipated in a light source;
- describe the effect of separation of light source and sensor on the intensity of light received;
- recognize the general features of a graph of light intensity against distance;
- explain how geometrical considerations lead to the inverse square law of light;
- describe the effect of the angle at which light strikes a surface on the intensity of light received;
- state Lambert’s cosine law of light;
- explain how geometrical considerations lead to Lambert’s cosine law of light;
- explain why reflectors are usually incorporated in luminaires;
- investigate the intensity and spread of light from a given luminaire;
- design a lighting installation to meet a brief which specifies the required illuminance on a surface at a stated distance;
- test a lighting solution to see whether it meets a given design specification.

What the student will need:

The Principles of Lighting course, contains the following equipment:

1	HP1832	150mm x 100mm mirror—with or without support block
1	HP2045	Shallow tray
1	HP2666	DC power supply, variable
1	HP4039	Tray lid
1	HP4561	ATP DT-1308 light meter
1	HP5540	Deep tray
1	HP7750	Daughter tray foam cut out
1	HP8600	Crash foam
1	HP9564	62mm daughter tray
1	LK2346	12V, 0.1A MES filament lamp
16	LK2399	12V MES power LED lamp
30	LK5250	connecting link
16	LK5291	MES lampholder
2	LK5603	red 4mm/4mm leads.
2	LK5604	black 4mm/4mm leads
1	LK6209	switch, on/off, carrier
1	LK8275	power supply carrier with battery symbol
1	LK8900	Locktronics Baseboard

In addition to this equipment, the student will need two multimeters (e.g. the LK1110 from Matrix).

Using this course:

The experiments in this course should be integrated with teaching to introduce the theory behind it, and reinforced with written examples, assignments and calculations.

The worksheets should be printed / photocopied / laminated, preferably in colour, for the students' use. They should make their own notes to enhance those provided in the Student Handbook. They are unlikely to need their own permanent copy of the worksheets.

This format encourages self-study, with students working at a rate that suits their ability. The instructor should monitor that students' understanding keeps pace with their progress through the worksheets. One way to do so is to 'sign off' each worksheet, as a student completes it, and in doing so have a brief chat with the student to assess grasp of the ideas involved in the exercises it contains.

Time:

It should take students between 4 and 6 hours to complete the worksheets. It is expected that a similar length of time will be needed to support the learning that takes place as a result.

Health and Safety!

**The LED bulbs are extremely bright.
Students must not stare at them for long periods of time!**

Worksheet	Notes for the Instructor	Time
Preamble	<p>It is assumed that students are able to:</p> <ul style="list-style-type: none"> • use a multimeter to measure the voltage across a component; • use a multimeter to measure the current through a component; • change the measurement range on the multimeter as appropriate; • understand and be able to manipulate multiples of units, such as milli, micro, kilo etc. • understand the significance of the superscripts "...²" and "...^½". <p>The appendices help with the use of multimeters to measure voltage, current and resistance.</p>	
Introduction	<p>The aim of this course is to examine the factors that go into designing an effective lighting system for a given environment. An obstacle to understanding this process is the vocabulary it uses, the concepts and the units in which they are measured. This introduction aims to describe and distinguish between these terms.</p> <p>One complication is that humans have a limited range of frequencies (or colours) that make up vision. Different animals 'see' different parts of the electromagnetic spectrum. A honey bee, for example cannot detect red light but can 'see' ultraviolet, which we cannot. The instructor may need to remind students about the electromagnetic spectrum and the very narrow band that is 'visible' light.</p> <p>To appear 'bright' to us, a light source must emit sufficient radiation in the part of the spectrum to which our eyes respond. Radiation in other parts is wasted energy. For this reason, the introduction begins by discussing energy efficiency coupled with an outline of the visible spectrum. Energy efficiency can be a misleading term. A source could be very efficient in converting incoming energy into electromagnetic radiation, while being useless as a light source if that radiation is not visible. A better term is luminous efficacy.</p> <p>The introduction includes a brief description of different types of luminaire. It would be helpful to have examples, or pictures of a range of common luminaires for students to look at. It also raises the issue of using panels of luminaires to deliver data as well as just light. The instructor, knowing the students, must decide how much technical information to discuss here.</p> <p>Another complication is the three-dimensional nature of the problem. A spherical light source may well give out light equally in all directions. Other light sources may produce a focussed beam, directing more light in one direction than in another.</p> <p>Again, a suitable light intensity depends on what activities are likely to place in that location. The Health and Safety at work regulations do not specify lighting levels but state that lighting levels should be appropriate for the work undertaken. The table gives typical values for a number of activities. Students could be asked to research health and safety implications of poor lighting.</p> <p>Many of the terms used by lighting engineers and technicians sound both similar and unfamiliar. 'Flux' applies to anything that flows. As a rough guide, "radiant..." means any type of electromagnetic radiation, whereas "...lum..." implies visible radiation. The next question is "arriving" or "reflected". In optics, the word "incident" is used to denote light arriving at a surface.</p> <p>The lumen is the unit of total energy emitted in all directions, whereas lux takes into account the area of the surface involved and measures the light intensity on unit area of the surface. The candela indicates the perceived brightness of the light from a source.</p>	20 - 30 mins

Worksheet	Notes for the Instructor	Time
1	<p>The aim is to give the students practice in using the light meter and give them a grasp of familiar light intensities.</p> <p>The activity as written is quite open-ended. In some situations, instructors may wish to tighten it down by specifying particular locations at which measurements should be made.</p> <p>The results are compared with the information in the table on page 5 to see what activities would be appropriate in these locations. Once again, this task could be modified to suit local conditions.</p>	20 - 30 mins
2	<p>The students measure the current through and voltage across a filament lamp and then a LED lamp both connected under similar conditions. The light meter is held at a fixed distance to measure the intensity of the light produced.</p> <p>Though not totally rigorous in its methodology, it demonstrates that the LED lamp is more efficient. The student should recognise that the LED is 'brighter' and the power calculation should show that it dissipates less electrical energy.</p> <p>Some students may require a reminder about the power formula. It is sufficient, at this level, to say that using milliamps in the formula produces an answer in milliwatts, without labouring through the multipliers involved.</p>	25 - 35 mins
3	<p>This investigation illustrates the inverse square law of illumination - that doubling the distance between the light source and the receiving surface reduces the light intensity to 25% of its value.</p> <p>The instructions make the point that subdued levels of ambient lighting are needed, by drawing blinds or by working under a bench, for example. The instructor must work out the best plan for this, knowing the accommodation and the students - working in total darkness would be great for the investigation but may provoke civil unrest!</p> <p>The investigation relies on the light emitted by one of the five LEDs on the LED lamp. This should be rotated in its holder until one of the LEDs points directly towards the sensor. The light sensor sits neatly up against the pillars of the baseboard. It may be necessary to rock the sensor slightly to achieve the highest possible reading for that location. The instructor may wish to monitor the readings to check that the student has interpreted the 'x10' and 'x100' labels on the higher scales.</p> <p>The Student Handbook instructs them to plot the results as a graph of intensity against distance. No scale is provided on the vertical axis, as these values will depend on exactly how the investigation is carried out. As a result, the instructor may need to intervene where the students have limited experience of drawing graphs. They then compare the shape of their graph with the inverse square law graph provided. They should see a similarity but not an exact match, as the inverse square law is valid only for a point source of light, whereas the LED lamp is an extended source, particularly when the separation is small. (The "five times rule" says that, to appear as a point source, the distance to the light source should be greater than five times the largest dimension of the source.)</p> <p>The Student Handbook includes a diagram showing the geometrical basis for the law. As separation increases, the beam gets wider and higher, resulting in the 'square' relationship. Depending on the mathematical abilities of the students, the instructor may need to expand on the meaning of 'directly proportional' and 'inversely proportional'.</p>	25 - 35 mins

Worksheet	Notes for the Instructor	Time
4	<p>The investigation examines the effect of angle between surface and beam on the intensity of illumination. Common sense suggests that the surface immediately beneath a light source receives the greatest intensity, but this study looks at how neighbouring locations fare.</p> <p>Students will probably have an intuitive feeling about this effect for the reasons outlined in the introduction - that evenings are cooler than mid-day, that equatorial countries do not have seasons etc. The task here is to enforce this feeling with actual measurement.</p> <p>To explore the effect of angle rigorously would be time-consuming and require more sophisticated equipment. The procedure suggested is not a rigorous examination but rather an illustration of Lambert's cosine law. Light intensity is sampled at three angles, 0°, 30° and 60° to the normal. Even this is difficult, requiring that the sensor is kept at the same distance from the light source while it is rotated to different positions. A physically small sensor would make the task easier, but would intercept less light, leading to lower readings, more prone to error. However, with care, the students will obtain results that illustrate the cosine law. The worksheet includes a template showing the three angles and suggesting the position of the baseboard.</p> <p>The Student Handbook expands on the significance of this law and shows its origin in geometry. One implication is that, to make accurate measurements of light intensity, the sensor must face the source rather than intercepting the light at an angle - hence the instruction in several worksheets to "...twist the sensor a little..."</p>	25 - 35 mins
5	<p>Light sources are rarely simply a bulb! Usually, they include a reflector of some kind. The effect is to bounce the unwanted cone of light travelling backwards from the lamp into the forward direction.</p> <p>Depending on the shape and position of the reflector, the result may be a focussed beam, a parallel beam or a diverging beam. It depends on the application as to which of these is used. In dentistry, for example, the aim is to concentrate the light onto a small area - the patient's mouth. In an office, the lights may be arranged so that their diverging beams meet at floor or desk level to provide extended uniform illumination.</p> <p>As we move towards the issue of how to design a lighting installation, the instructor may wish to spend time discussing requirements like these. Photographs of a range of applications would reinforce these ideas.</p> <p>Students are expected to plan the investigation themselves, following the outline given in the worksheet. There are two positions for the LED lamp with respect to the reflector, giving three elements to the plan - with reflector and lamp in position A, with reflector and lamp in position B and without reflector.</p> <p>The instructor may choose to 'brain-storm' the design of the investigation with the students beforehand, focussing on which elements are variable and which must stay the same within the investigation.</p> <p>The Student Handbook is used to record the results of their investigations.</p>	25 - 35 mins

Worksheet	Notes for the Instructor	Time
6	<p>The idea is to give students a relatively open-ended challenge incorporating the issues raised in earlier worksheets. It involves mapping the intensity produced by a relatively high intensity luminaire and investigating the relationship between intensity and number of LED lamps.</p> <p>It uses all sixteen LED lamps initially. (The power supply can supply power to thirty, so there is no problem here.) The notes advise students to reduce the number of LED lamps by removing those circled. This ensures that the beam remains relatively uniform.</p> <p>Instructors should look for good experimental technique - devising a sound method for measuring the distance from the luminaire to the light sensor - having a reliable means for keeping the light sensor at a fixed distance from the luminaire - taking sensible steps to reduce the ambient light level etc.</p> <p>The investigation could be extended to investigate the shape of the beam for a variety of arrangements of the LED lamps.</p> <p>The investigation gives students the opportunity to compose a concise yet detailed report on their findings. The instructor may choose to have them deliver their findings to the rest of the class in a short illustrated talk.</p>	40 - 60 mins
7	<p>A workstation is used to carry out intricate work, such as soldering printed circuit boards. It requires adequate lighting. The task is to design a lighting installation for it to meet the given brief.</p> <p>The design should incorporate the smallest number of LED lamps as possible in order to reduce costs. In the real world, a reflector would be very desirable as a means to minimise this number. It is excluded here because of the risk of short-circuiting the power supply.</p> <p>The instructor could request preliminary designs to check that they do not include short-circuits or have lamps in series (which would not operate at full brightness.) The students could be given instructions about the testing regime or be required to create their own.</p> <p>They write a report on their design in the Student Handbook.</p>	40 - 60 mins