

# locktronics

Simplifying Electricity

Electronic components and circuits pack 2

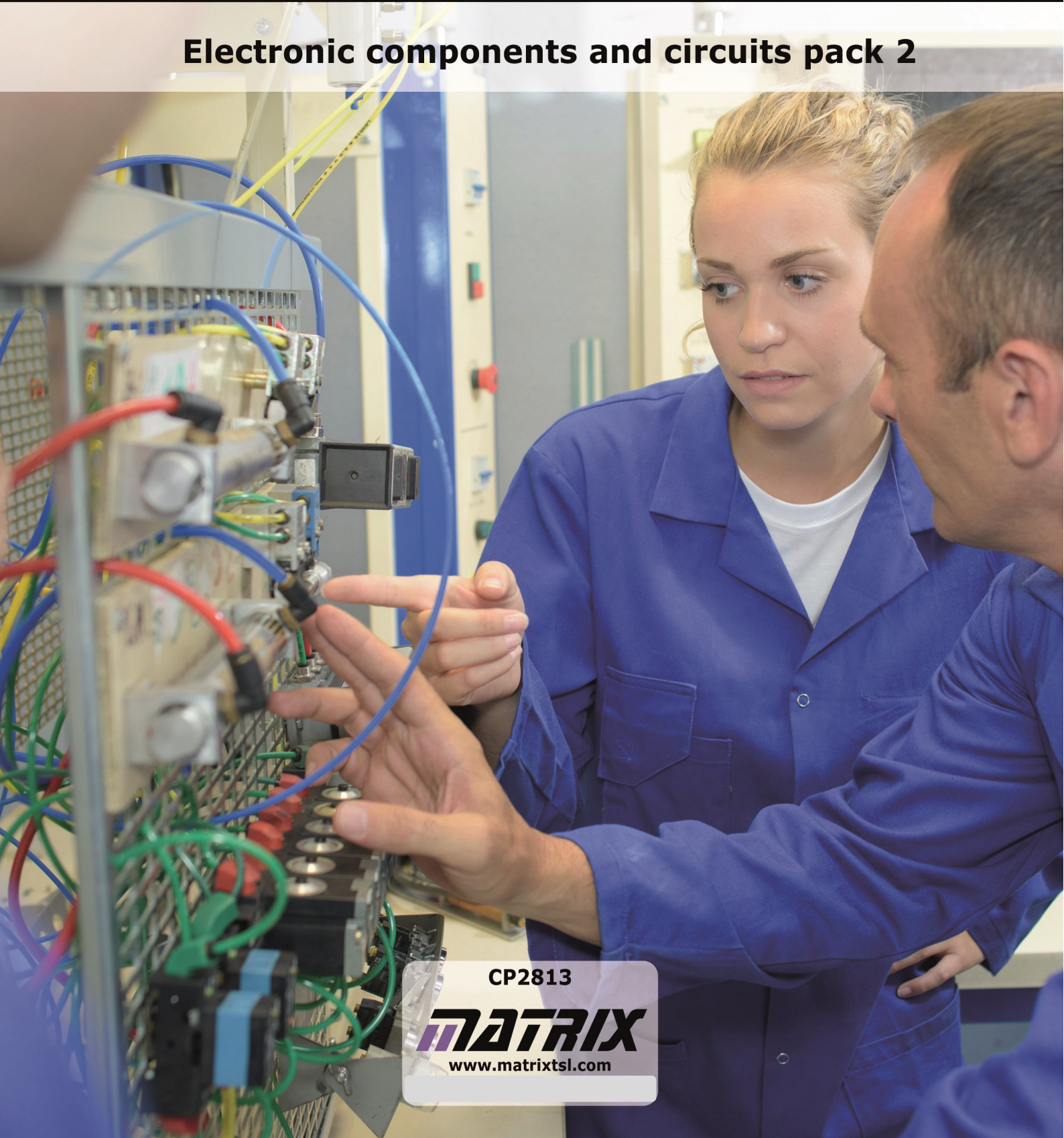

CP2813

**MATRIX**







[www.matrixtsl.com](http://www.matrixtsl.com)

Topic	Page
Introduction	3
Circuit training	4
Power supplies (oscilloscope)	5
Power supplies (AC or DC which is used?)	6
Power supplies (AC or DC does it matter?)	7
The resistor	8
The capacitor	9
Charging a capacitor	10
The diode	11
Rectification	12
Low voltage DC power supply	13
The zenor diode voltage regulator	14
The LED	15
Protecting the LED	16
Sensors	17
Temperature-sensing unit	18
Light-sensing unit	19
The potentiometer-structure	20
Two ways to use a potentiometer	21
Improved temperature-sensing unit	22
The transistor	23
Adding a transistor amplifier	24
A simple time delay circuit	25
Soft-start motor circuit	27
Lamp dimmer-1	28
Phase control	29
Lamp dimmer-2	30
Electrical Installation L2 Appx	31
Appx 1 Measuring voltage	32
Appx 2 Measuring current	33
Appx 3 Measuring resistance	34
Student Handbook	35
Instructor Guide	50

The course aims to prepare you for Topic 4 of Unit 202 - “Electrical Science” part of the City and Guilds Level 2 “Technical Certificate in Electrical Installations” (8202-20).

As you work through the course, the layouts show you how to build the systems and each task details how to test them.

There are a variety of different tasks, identified by a series of icons.

Icon	Significance
	Content gives information about electricity, or explains some terminology
	Practical activity
	Relates the current activity to jobs in the industrial / domestic realm
	Open-ended activity where the students designs the activity
	Health and Safety related issue
	Activity involves a formula or calculation
	Power supply flags indicate which type of power supply to use.

For your records:

- It is important that you keep accurate records of what you do.
- A Student Handbook is available to assist with these records.
- In addition, take whatever notes you feel are necessary to help with this.



# Circuit training

This activity is **optional**.

- If you recently followed the 'Electrical Installation 1' course, it is probably unnecessary.
- If you are new to Locktronics, it is a useful way to introduce the kit.



Build a circuit that makes a bulb light, using a 12V 0.1A bulb and the 12V AC power supply.

The hardware:

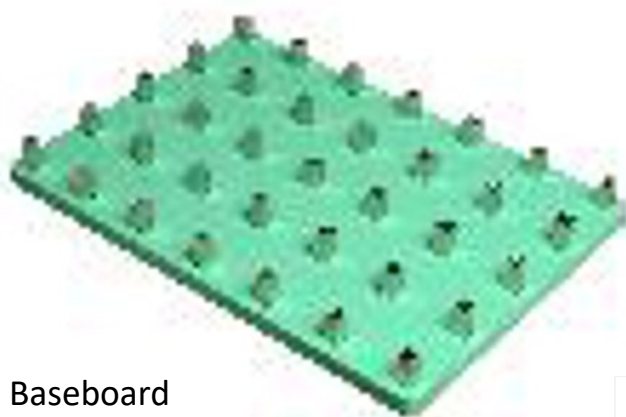

Baseboard

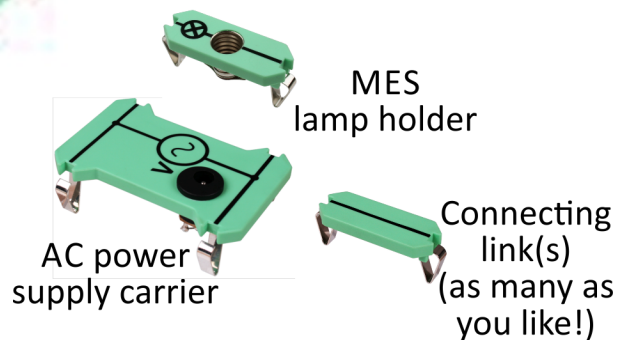
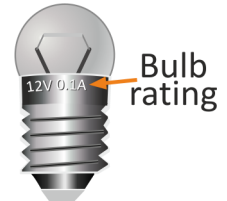

AC power supply carrier

MES lamp holder

Connecting link(s)  
(as many as you like!)

Answer the question in the Student Handbook.

## Power supply:

**i**

- drives current around the circuit;
- has two terminals (connection points) one 'positive' the other 'negative';
- current flows from the positive terminal to the negative terminal.

## DC power supply - (DC = direct current):

- one terminal is always positive, the other always negative;
- 'one-way traffic' - current always flows the same way around the circuit.

## AC power supply - (AC = alternating current):

- one terminal positive, the other negative and then they swap, repeatedly;
- 'two-way traffic' - current flows clockwise, then anticlockwise around the circuit.

# Power supplies - 1

**i** There are two types of power supply. One delivers **DC** power and the other **AC** power. The difference between them is best shown by looking how the voltage changes over a period of time, i.e. looking at a voltage / time graph.

These can be produced using an **oscilloscope**. Used more in electronics, they display the signal as a graph, with voltage on the vertical axis and time on the horizontal axis.

Some digital oscilloscopes, like the 'Picoscope', which produced the graphs shown below, generate signals which are then processed by a computer connected to it.



**DC power** - the **voltage** stays steady over a period of time.



**AC power** - the **voltage** changes all the time and even goes negative sometimes, forcing the current to flow in the opposite direction.

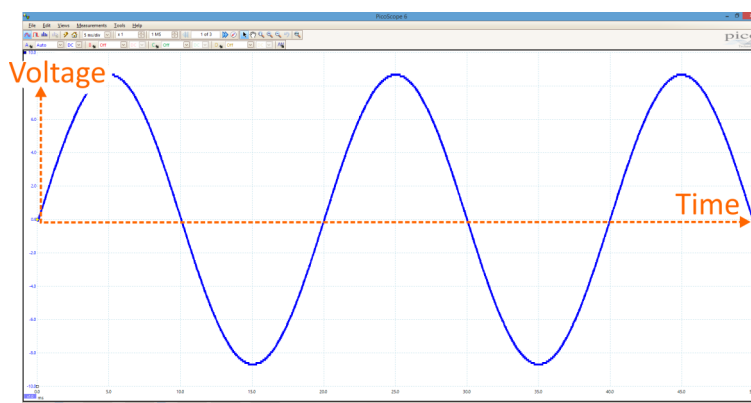

# Power supplies - 2



## AC or DC - which is used?

Each has its uses!

Electricity is usually generated and transmitted as AC because:

- alternators (AC) are usually more efficient than dynamos (DC);
- transformers, which work only on AC, can modify voltage and current efficiently.

Electronic devices - mobile phones, computers, televisions etc. usually require DC.

### AC power:

can be converted into DC using the processes of rectification and regulation.

### DC power:

can be converted into AC using a device called an inverter.

### DC power supplies:

- **battery** - chemical reactions generate DC voltages, e.g. 'lead-acid' batteries;
- **solar cell** - photo-voltaic ('solar') cells convert light energy into DC electricity ;
- **dynamo** - a rotating coil of wire near a magnet generates DC using a 'commutator' to connect the coil to the rest of the circuit.



### AC power supplies:

- **alternator** - another example of a rotating coil of wire near a magnet;
  - a 'slip-ring' connects to the rest of the circuit;
  - the coil can be driven by:

- high-pressure steam, in a power station;
- wind in a wind-generator;
- falling water in a hydro-electric power station.



# Power supplies - 3

## AC or DC - does it matter?

**Answer** - Yes - it almost always does!

The next investigation shows that they work in different ways.

The task - connect a 12V DC motor firstly to a 12V DC power supply and then to a 12V AC supply.

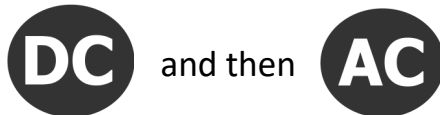

1. Build the layout shown below.  
The 100Ω resistor is used to reduce the voltage across the motor.
2. Connect the 12V DC power supply and switch on.
3. Notice that the motor behaves normally and rotates at high speed.
4. Now replace the DC power supply with a 12V AC power supply and switch on.
5. The motor does not rotate. Hold the plastic gear wheel - you can feel it vibrating backwards and forwards. It is trying to rotate one way and then the other, in step with the alternating current.

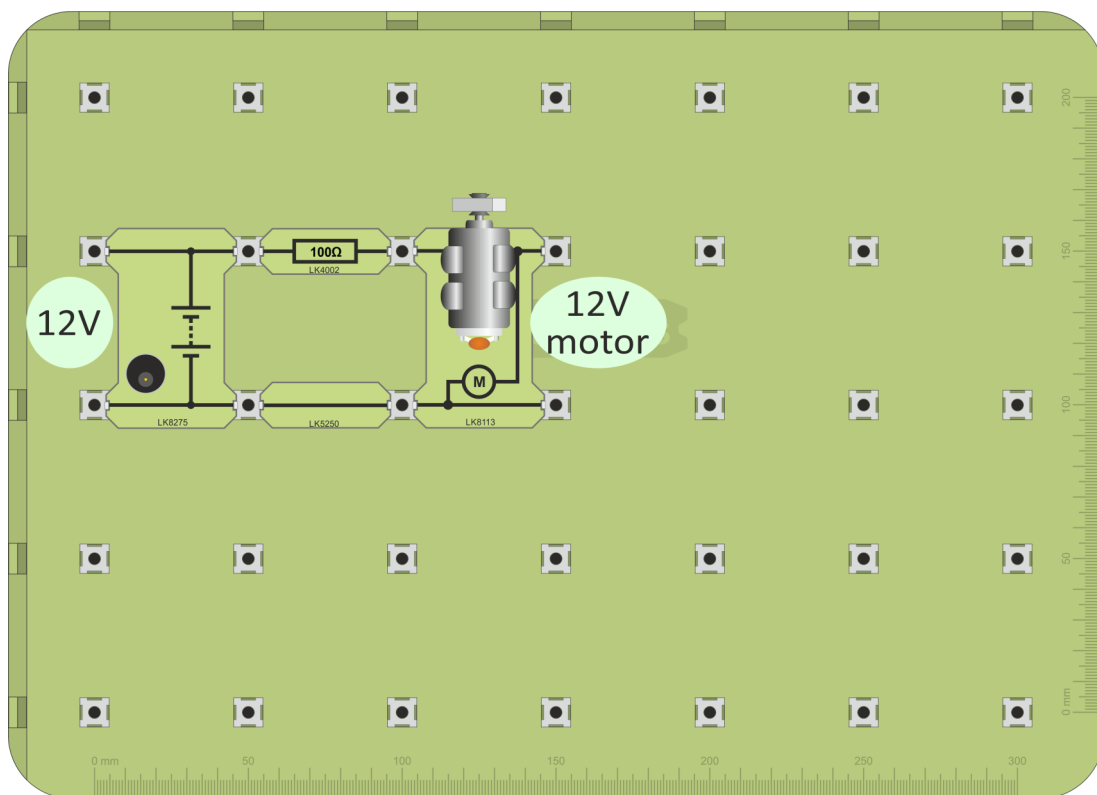

6. Answer the questions in the Student Handbook.

# The resistor

i

We can change the flow of *water* using a tap.  
With *electricity*, we change the flow using a **resistor**.

For electrons, adding resistance is like asking you to run in mud.  
It takes more energy!

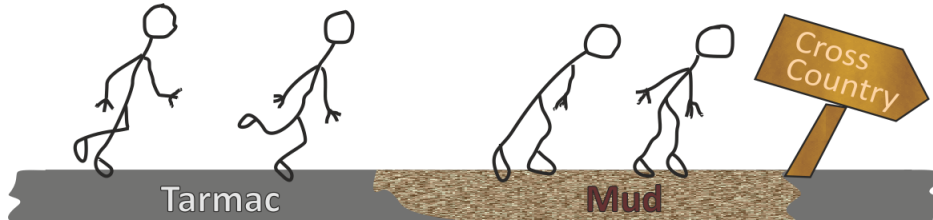

Commercially-made resistors often look like the one opposite.  
The colour of the stripes is significant, but that is for later!



1. Build the layout shown below.
2. Connect the 12V power supply and switch on.
3. To see the effect of the resistor, press the push-switch.

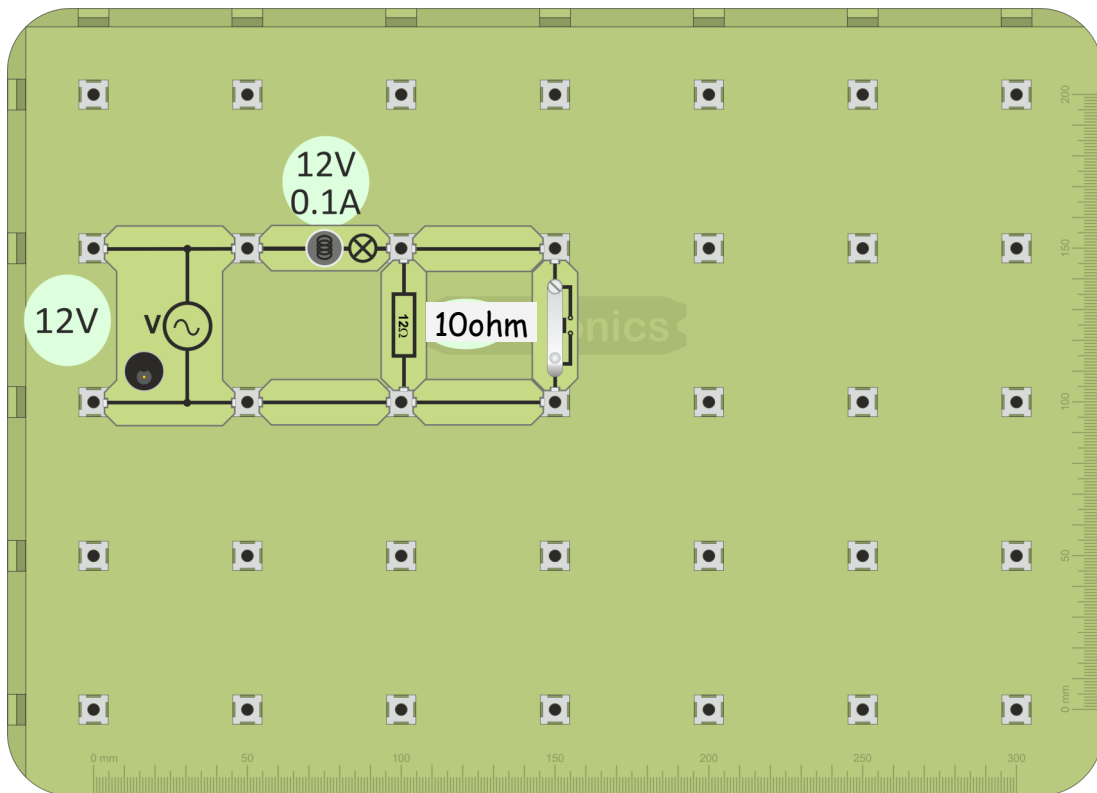

4. Now answer the questions in the Student Handbook.



# The capacitor



A capacitor consists of two metal plates, (A and C in the diagram), separated by an insulating sheet, (B).

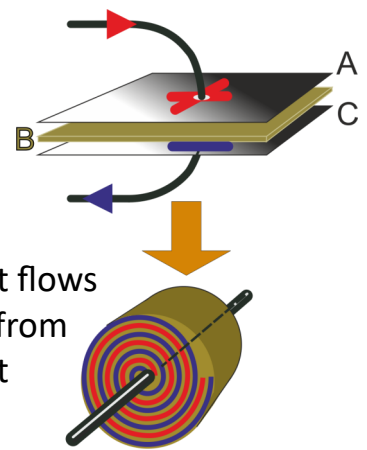

To save room, this 'sandwich' is rolled up into a 'Swiss roll', in such a way that the metal sheets do not touch.



When connected to a power supply, current flows from the power supply onto one plate and from the other plate back to the power supply, for a short time.

This leaves one plate positively charged and the other negatively charged by the same amount. The capacitor stores this charge until it can flow around a circuit.

Capacitors are rather like 'buckets' that store electric charge. As they fill up, the voltage across them increases until they

are fully charged (the 'bucket' is full.) The size of the 'bucket'

is given by the capacitance. This is measured in units called farads (F) though capacitors used for most purposes are measured in microfarads ( $\mu\text{F}$ , - millionths of a farad) or smaller. The wider the bucket, the more water it takes to raise the level.



The bigger the capacitance, the more electrical charge it takes to raise the voltage.

Two  $1\mu\text{F}$  capacitors

electrolytic    non-electrolytic

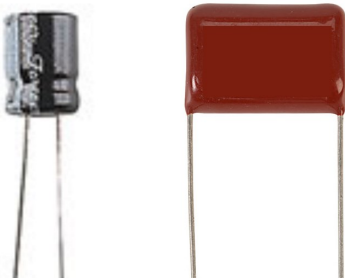

Capacitors come in two main types - electrolytic and non-electrolytic. However, electrolytic capacitors are polarised - they have positive terminal and negative terminals and must always be connected the right way round. This means that they cannot be used in AC circuits. (In the photograph at the top of the page, the arrows point in the direction of the negative terminal.)

Non-electrolytic capacitors can be connected either way round, but are physically larger for a given value of capacitance.

## Take care!



As well as taking care not to connect electrolytic capacitors the wrong way round, you need to check the 'working voltage' rating for the capacitor. This is the maximum safe voltage that can be used with it.

# Charging a capacitor

The next investigation looks in more detail at how the voltage across a capacitor changes as it 'fills up' with electrical charge.



1. Build the layout shown below.

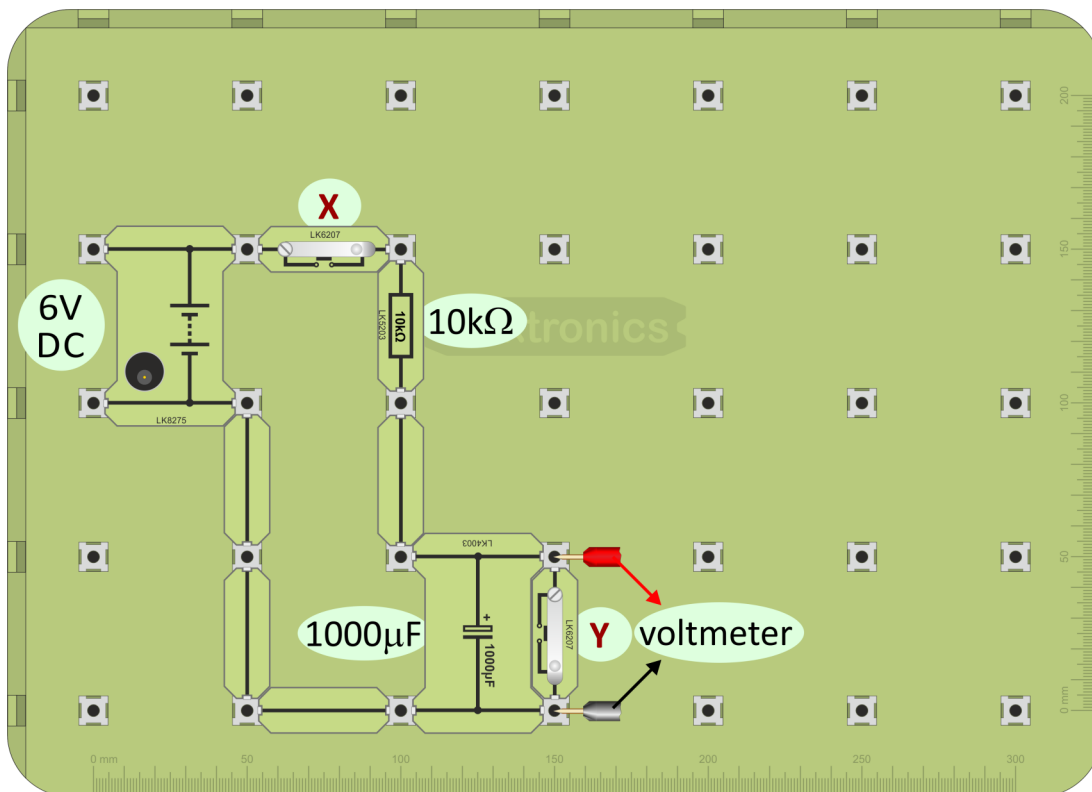

**Take care** to connect the capacitor the right way round!

2. Press and hold down switch **X**. Watch the voltmeter reading as you do so. (To repeat the test, first press switch **Y** to discharge the capacitor.) Estimate how long it takes to charge to 3V.
3. Try other values of resistor and capacitor. Can you see a pattern in your observations?
4. Answer the questions in the Student Handbook.

# The diode

**Rectification** is the name of the process used to turn AC into DC. It usually relies on the fact that current can flow only one way through a diode.

The name 'diode' tells us that it has only two ('di...') electrodes ('...ode'). These are known as the **anode** and the **cathode**.

The diagram shows a photograph of a common type of diode together with its circuit symbol. The **cathode** is identified by a silver stripe on the body of the diode.

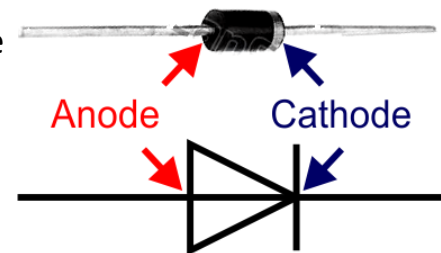

When the **anode** is more positive than the **cathode**, the diode is 'forward-biased'. When the **cathode** is more positive, it is 'reverse-biased'.

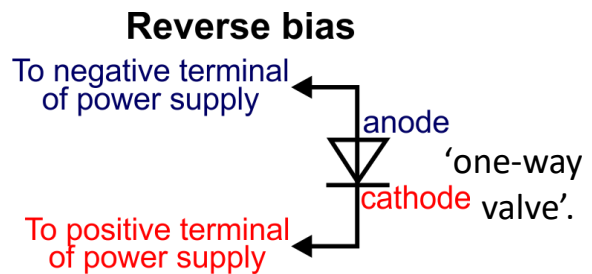
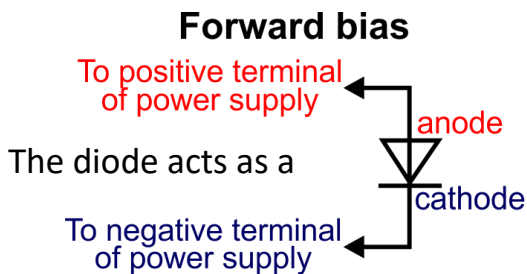

It allows current to flow through it only when it is forward-biased.



When reverse-biased, it does not conduct at all (for low voltages.)

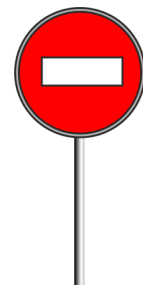

We have just seen that the motor does not work when the electricity supply is AC. The next investigation shows that a diode converts the AC power from the power supply to DC, which can operate the motor.



1. Build the layout shown below which is virtually identical to the one you just used, but has a diode added. Once again, the  $100\Omega$  resistor is included to reduce the voltage across the motor.
2. Connect the 12V AC power supply and switch on.

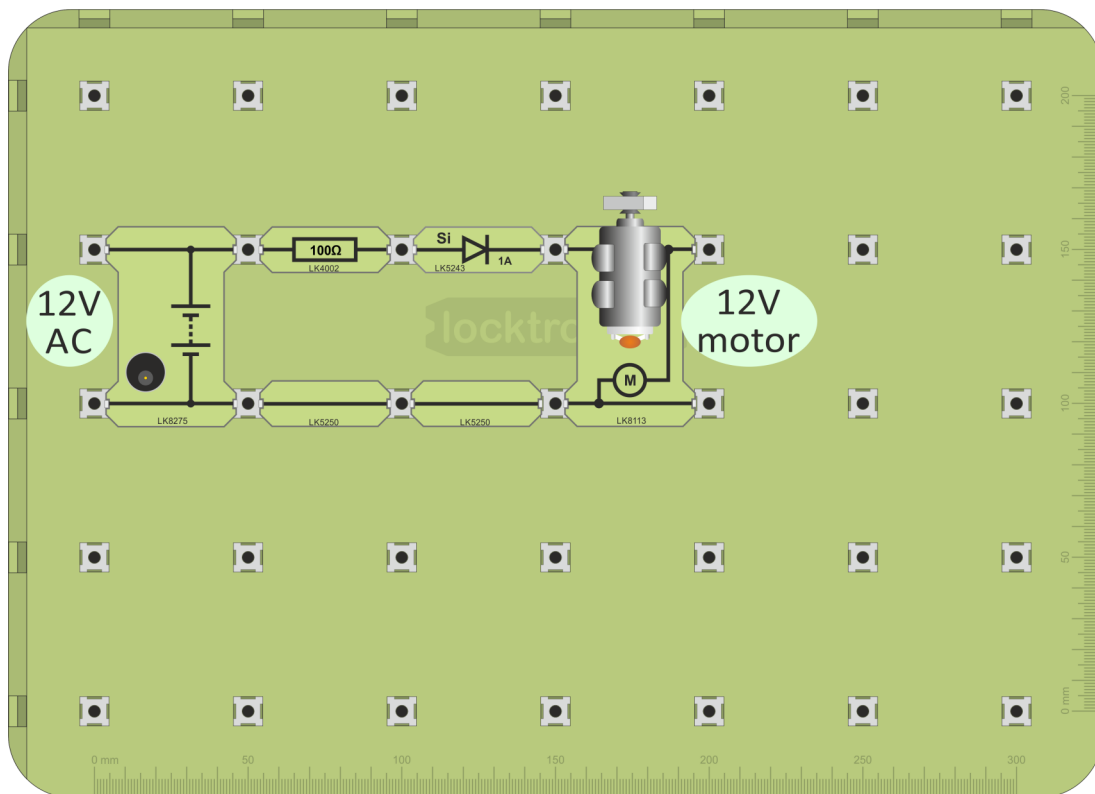

3. Check whether the motor is turning or just twitching.  
If it is turning, then the electricity supply to it must be DC.  
If it is twitching, then the supply is still AC.
4. Answer the questions in the Student Handbook.

# Low voltage DC power supply

The aim is to convert a high-voltage (240V) AC mains supply into a low voltage (12V, typically) DC supply that can be used with electronic equipment.

This process can be divided into the stages, shown in the block diagram:

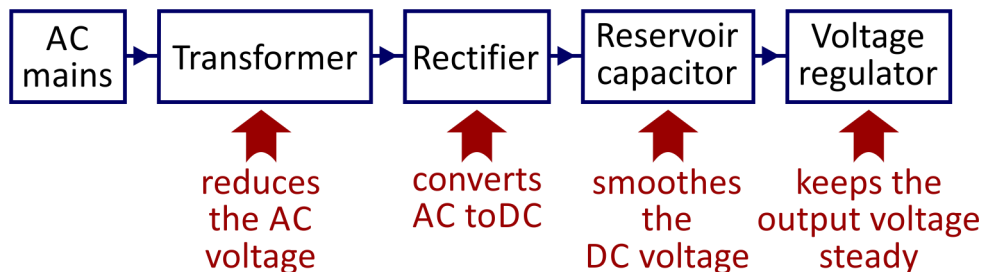

We have seen that a diode can be used as the rectifier and that a capacitor behaves rather like a bucket of charge, topping up the output when needed.

An ideal power supply maintains a steady voltage no matter what current is taken from it. The extent to which a real power supply achieves this is measured by a property called its **voltage regulation**.

**Zener diodes** are designed to 'break down' and conduct electricity at a particular value of reverse-bias voltage. They maintain that voltage for a wide range of currents. This makes them useful as voltage regulators in power supplies. The circuit symbol for a zener diode is shown in the diagram, together with the voltage that it tries to sustain when reverse-biased.

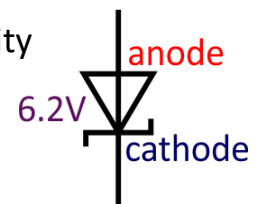

One form of voltage regulator consists of a resistor and zener diode in series with it. The zener diode is connected in reverse bias. The regulator in the diagram, using a 6.2V zener diode and a 100Ω resistor is designed to give an output voltage of 6.2V, leaving the rest of the input voltage across the resistor.

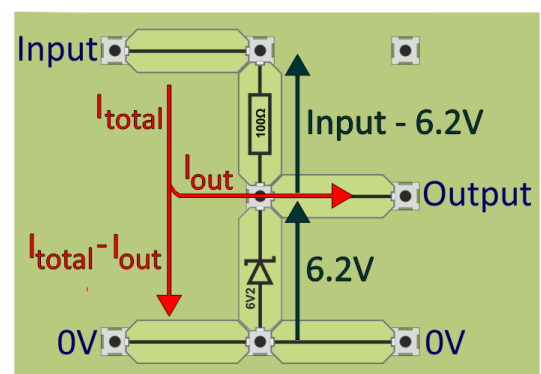

The current through the resistor divides between the output and the zener diode. When the output current is zero, the full current flows through the zener diode. In this situation, the power dissipated in the zener diode is a maximum and the diode will be at its hottest.



# The zener diode voltage regulator



1. Build the layout shown below.  
Notice the high power ratings of the resistor and zener diode.  
Be sure to connect the zener diode as shown, in reverse bias.  
To begin with, unscrew the MES bulbs in their holders so that they do NOT light up.
2. Connect the 12V AC power supply and switch on.

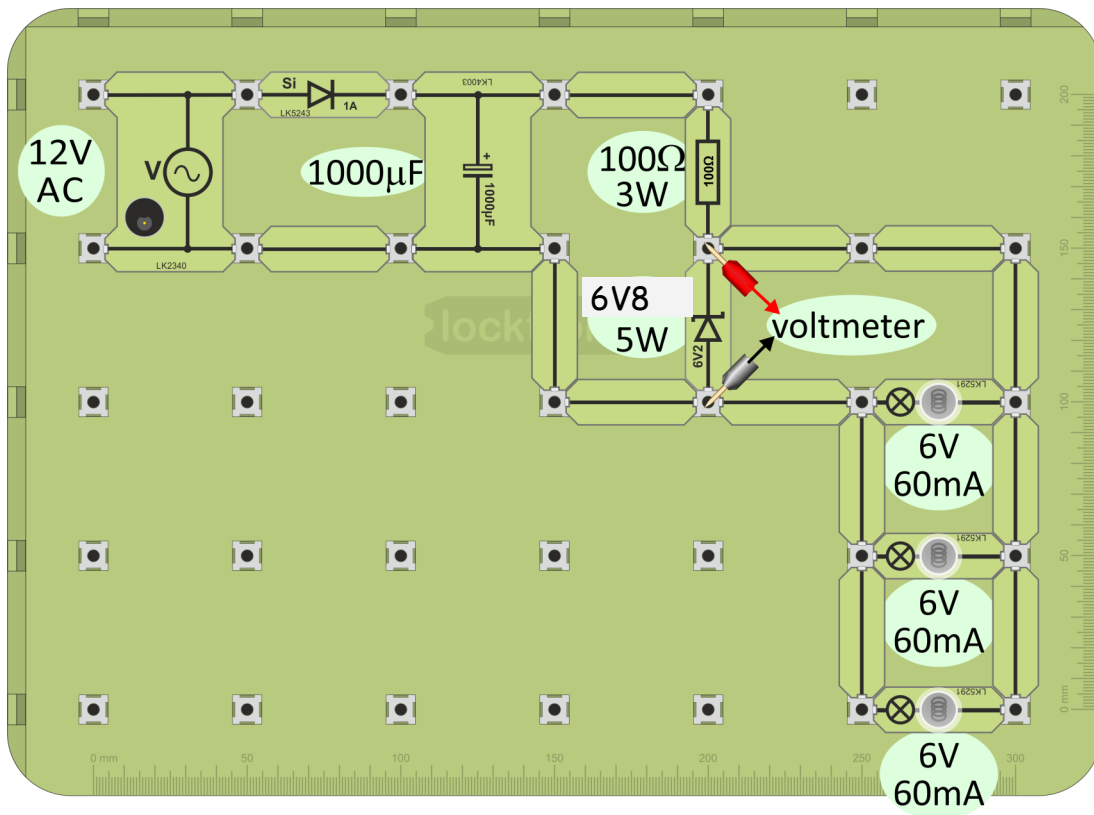

3. Set up a multimeter as a voltmeter reading up to 20V DC. Connect it to measure the output from the voltage regulator.  
Watch what happens to the meter reading as you work through the next steps of the investigation.
4. Screw in each bulb in turn so that they light up. As you do so, notice the effect on the other lamps that are already lit (and on the voltmeter reading).
5. Answer the questions in the Student Handbook.

The LED (light-emitting diode) is similar to the power diode in that it conducts electricity only when forward-biased. However, when a current passes through it, some of the energy in it is transformed into light. Whereas the filament lamp gets so hot that it glows, the LED creates light without creating a high temperature. This gives LEDs a much higher energy efficiency (around six times higher than filament lamps.)

The diagram shows a photograph of a green LED together with its circuit symbol.

The **cathode** is usually the shorter of the two legs.

The colour of the light from the LED comes directly from the generation process and depends on the chemical elements used in the semiconducting crystal at its heart.

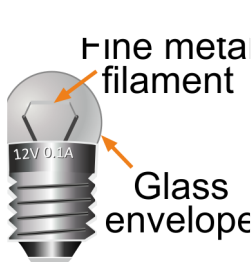
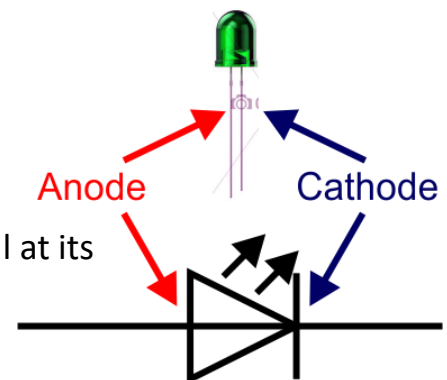

In the traditional filament lamp (e.g. torch bulb) light is produced because the wire filament (usually tungsten) is heated to such a high temperature ( $\sim 2500^{\circ}\text{C}$ ) that it glows yellow hot.

To reduce evaporation of the metal, the glass envelope is filled with an inert gas at low pressure. They are not energy efficient (typically 2-3% of the energy supplied to it is emitted as light) as most energy goes into heating the filament.

LEDs have a number of advantages over filament lamps:

- lower energy consumption - no hot filament;
- longer lifetime - no expansion and contraction of the wire filament;
- physically robust:
  - no glass envelope;
  - no delicate filament;
- smaller size;
- faster switching.

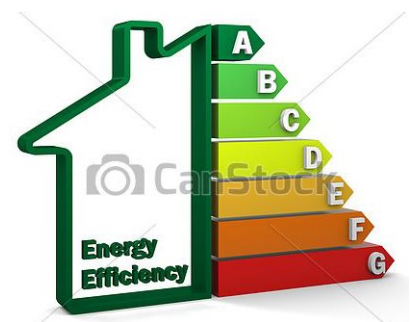

# Protecting the LED

**i** LEDs come in a variety of colours, shapes and intensity. However, none can withstand high voltages, either for forward-bias or for reverse-bias.

A typical LED cannot withstand more than about 3V under forward-bias and around 5V when reverse-biased. Usually, the power supply voltage is greater than this.

A series resistor is used to protect the LED when forward-biased.

When reverse biased, a diode can protect it, as the diagram shows:

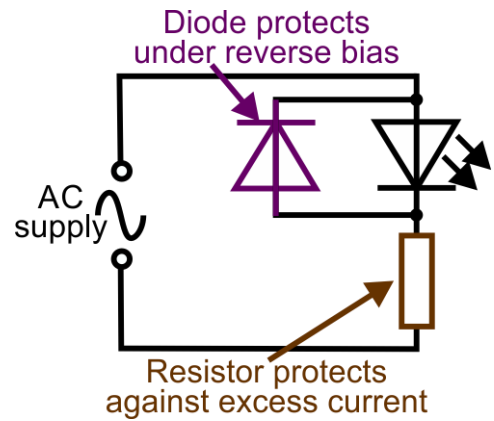

1. Build the layout below, taking care to connect the diode the right way round!
2. Connect the 12V AC power supply and switch on.
3. Press the push-switch to light the LED

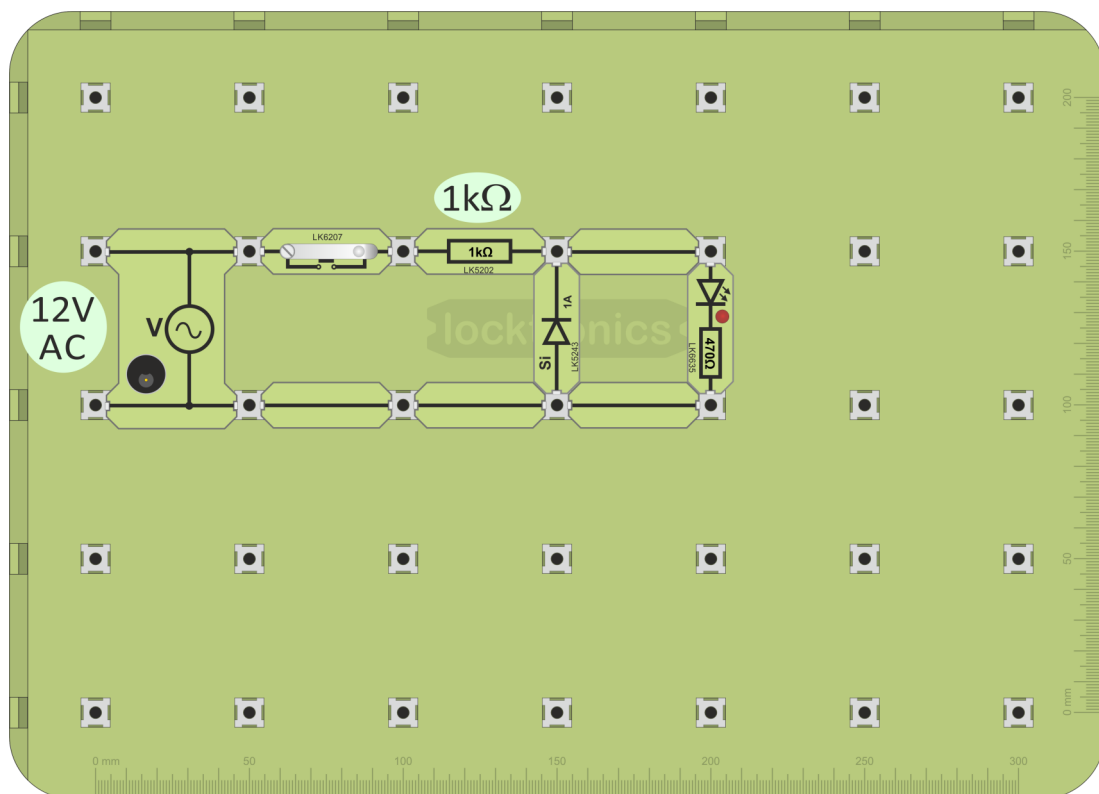

4. Now answer the questions in the Student Handbook!

**i**

To control something, we need to be able to measure it!

Electronic instrumentation plays a vital role in this. Very often, at the heart of such instrumentation is a sensor connected in a voltage divider subsystem.



We have seen that resistors are used to protect other components from excessive currents. They can also be used in voltage dividers to split up the voltage from a power supply into smaller predictable portions.

This is particularly useful when one of the resistors is a sensing component, such as a LDR (light-dependent resistor,) or a thermistor, (temperature-dependent resistor.)

The output voltage can represent temperature, light-level, pressure, humidity, strain or other physical quantities, depending on the type of sensor used.



## A. Investigating the thermistor:

1. Connect the thermistor carrier to the multimeter, set to measure resistance up to 2 k $\Omega$ .
2. Measure its resistance at room temperature.
3. Hold the thermistor between thumb and forefinger to warm it and notice the effect of the increasing temperature on its resistance.

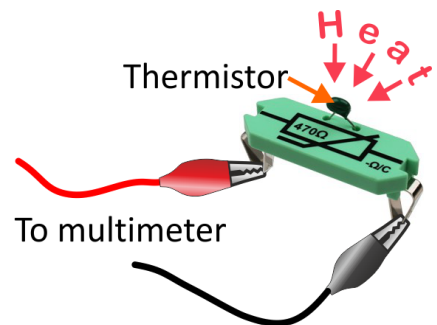

## B. Investigating the LDR:

1. Next, connect a LDR to the multimeter.
2. Measure its resistance under normal room lighting.
3. Shade the LDR with your hand and notice the effect on its resistance as you do so.
4. Now answer the questions in the Student Handbook!

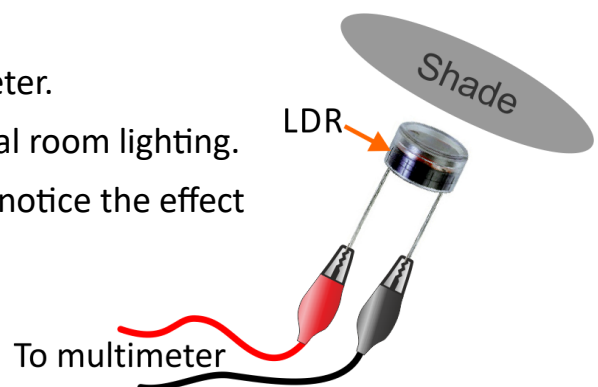

# Temperature-sensing unit



1. Build the layout below.
2. Set up a multimeter to read DC voltages up to 20V and connect it across the  $1\text{k}\Omega$  resistor, as shown.
3. Set the DC power supply to 6V, connect it and switch on.

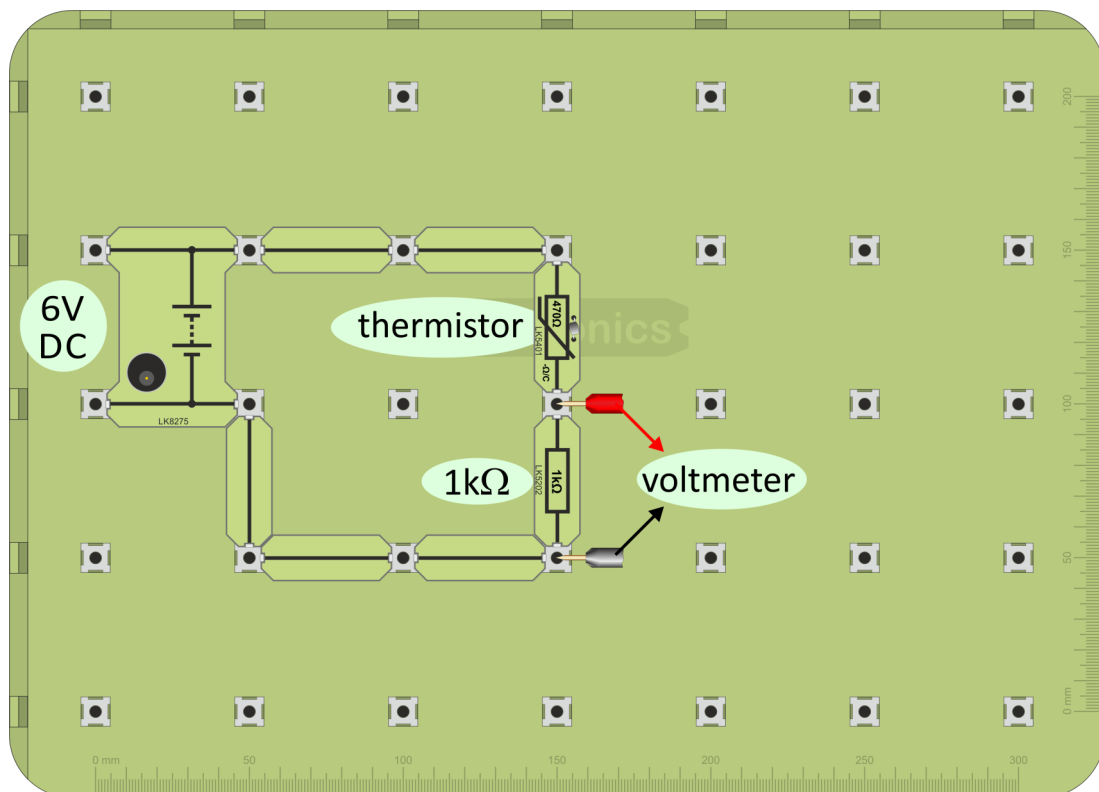

4. The output voltage from the sensing-unit is taken as the voltage across the  $1\text{k}\Omega$  resistor.  
Measure this voltage with the thermistor at room temperature.
5. Warm up the thermistor by holding it between your finger and thumb.  
Watch the voltmeter as you do so.
6. Swap over the thermistor and resistor, but leave the voltmeter where it is, so that it is now connected across the thermistor. Warm it up, as before. Notice the effect on the output voltage as you do so.
7. Now answer the questions in the Student Handbook!





1. Build the layout below.
2. Set up a multimeter to read DC voltages up to 20V and connect it across the photodiode, as shown.
3. Set the DC power supply to 6V, connect it and switch on.

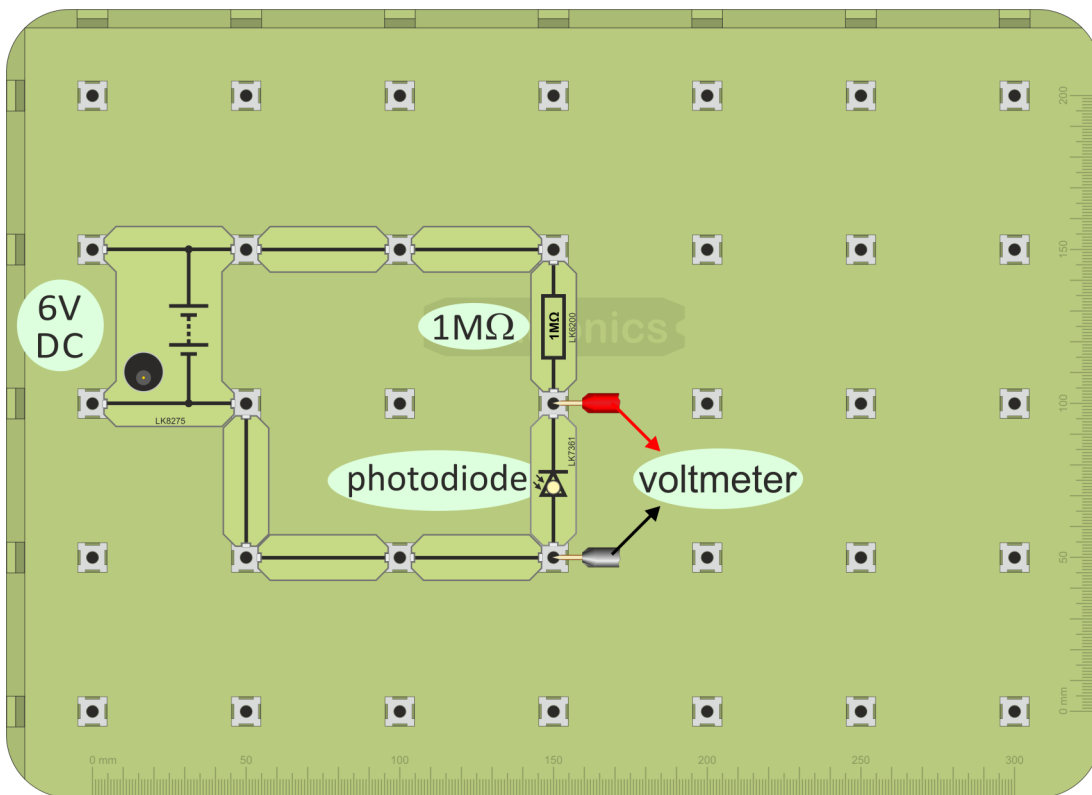

4. The output voltage is now taken as the voltage across the photodiode. Measure this voltage under normal room lighting.
5. Reduce the light level by shading the photodiode with your hand. Watch the voltmeter as you do so.

### Challenge:



Rearrange the circuit to create the opposite effect on output voltage when the photodiode is shaded.

6. Now answer the questions in the Student Handbook!

# The potentiometer - structure

**i**

The potentiometer, usually called 'pot', is widely used to control :

- loudness and tone in audio devices;
- brightness, in lighting systems;
- speed and position, in motors etc.

They are available in a variety of formats - linear and rotary - single-turn and multi-turn ...

The photograph shows part of an audio mixing desk, used in a recording studio. It uses both linear (slider) and rotary pots.

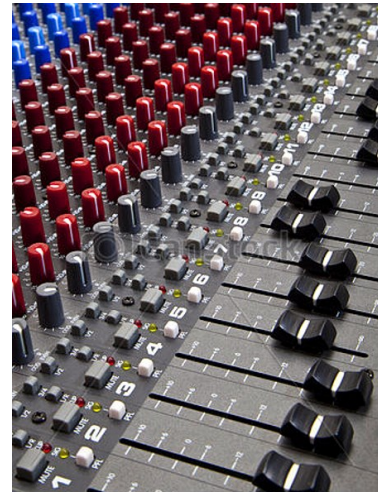

The following diagram illustrates the internal structure of a rotary pot.

When the spindle is rotated, a metal 'wiper' slides across a 'C'-shaped track, made from a carbon compound, or from a flattened spiral of resistance wire.

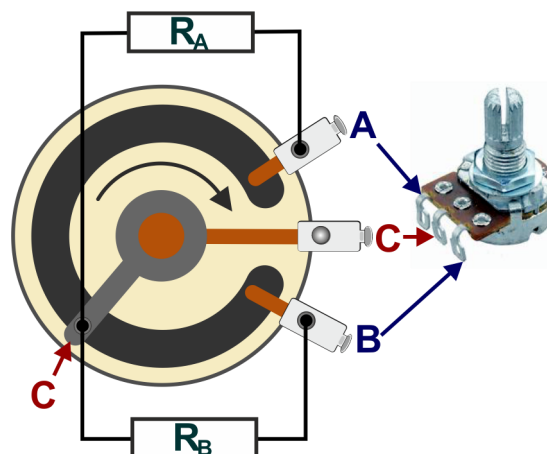

The three terminals create two variable resistors:

- $R_A$ , between terminal **A** and terminal **C**;
- $R_B$ , between terminal **B** and terminal **C**.

When the slider rotates, the length of track between the terminals changes, altering the resistance of the variable resistors. When it moves clockwise in the diagram, for example,  $R_A$  gets smaller and  $R_B$  increases.

The resistance between **A** and **B** is the full resistance of the track and is fixed.

The pot is used in two ways:

- as a variable resistor, using only two terminals, either **A** and **C** or **B** and **C**;
- as a voltage divider, using all three terminals.

The investigations on the next page illustrate the difference between these uses.

# Two ways to use a potentiometer



1. Build the first layout shown below, which uses the 25Ω pot as a variable resistor. Like a resistor, it has only two terminals.
2. Connect the 12V power supply and switch on.
3. Press the push-switch.

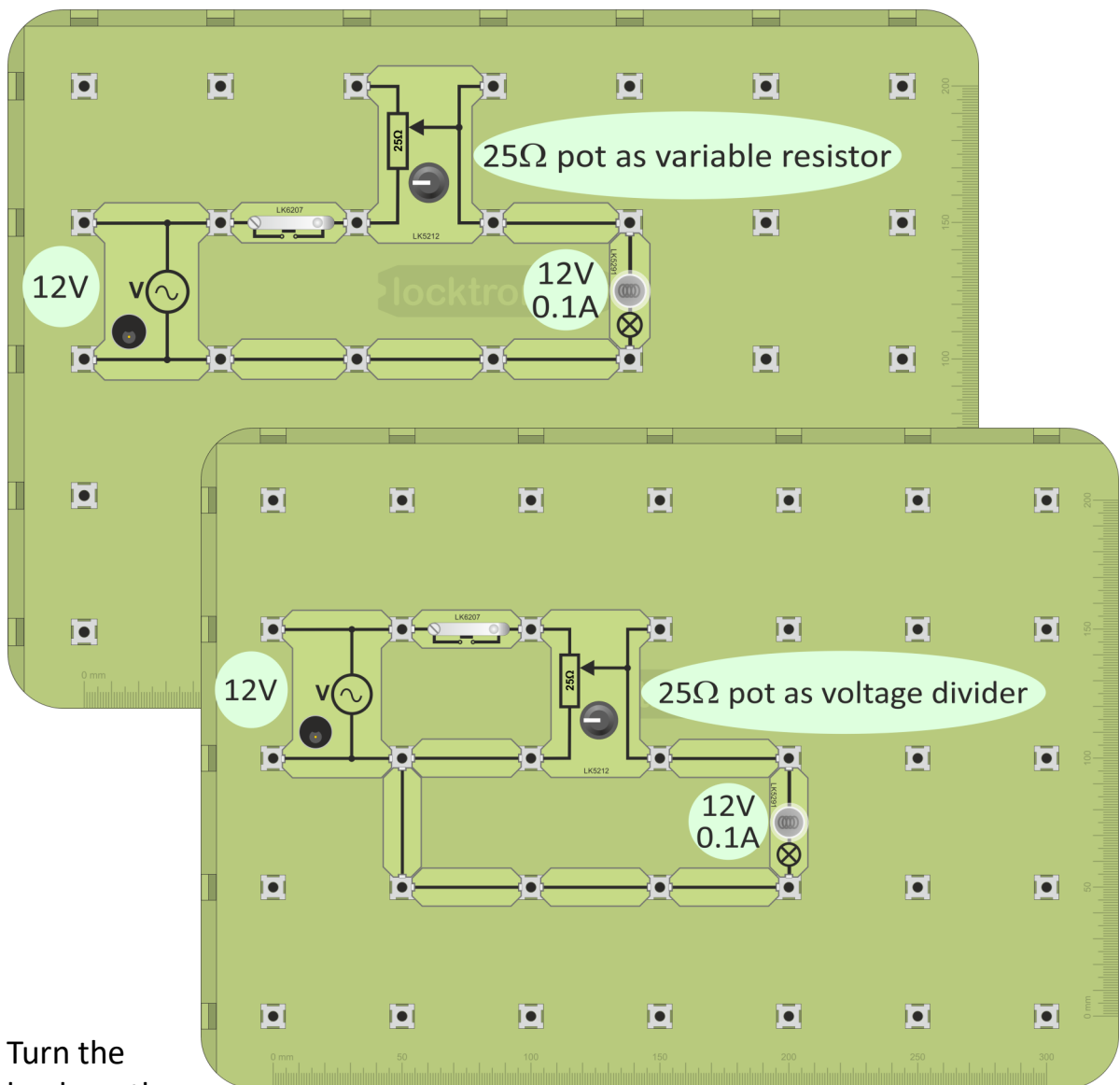

4. Turn the knob on the pot to see the effect this has on the bulb.
4. Now build the second circuit. This one uses the pot as a voltage divider - all three terminals are used.
5. Connect the 12V power supply, switch on and press the push-switch.
6. Turn the knob on the pot. Compare the effect of this arrangement with the

A pot is often used as a variable resistor as part of a sensing unit.



**DC**

1. Build the layout shown below, which uses a  $1\text{k}\Omega$  pot as a variable resistor within a temperature-sensing unit.
2. Set up a multimeter to read DC voltages up to 20V and connect it to measure the output voltage, as shown.

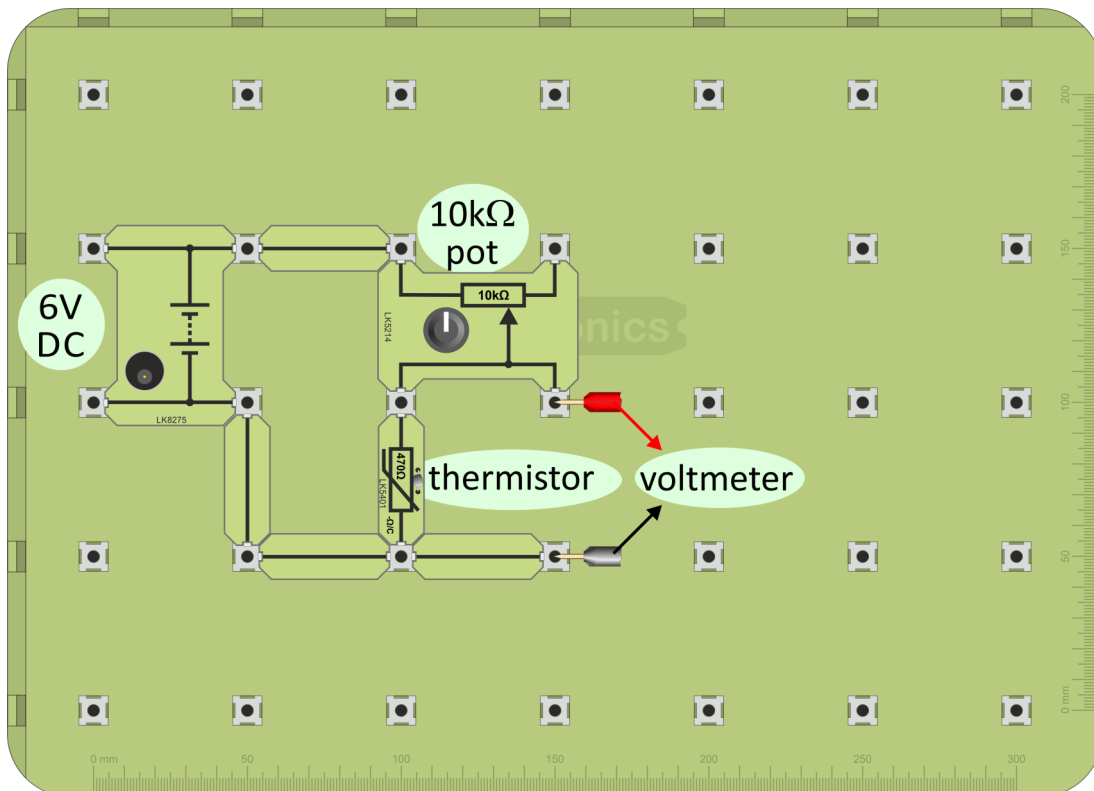

3. Set the DC power supply to 6V, connect it and switch on.
4. Turn the knob on the pot from one extreme position to the other. Notice the effect on the output voltage.
5. With the pot set roughly mid-way around its travel, test that the system still works in the same way as a temperature-sensing unit.
6. Answer the questions in the Student Handbook.

# The transistor

Though rarely seen by itself, the transistor is at the heart of nearly all modern electronic systems.

It is made from a single crystal of a semiconducting material such as silicon. In its pure form, silicon does not conduct electricity very well - hence the name *semiconductor*. Its relatively high electrical resistance falls when selected impurities are added. Moreover, it conducts in ways specific to the type of impurity added.



One type makes it conduct rather like a metal, such as copper, using a 'sea' of free electrons. This type of silicon is called '**n-type**' (as it conducts using free, negatively-charged electrons.)

The other type enables conduction using electrons which are normally trapped in the silicon. The impurities create 'holes' (missing electrons) in the crystal structure. Since electrons are negatively-charged, a lack of an electron seems to have a **positive charge**. Silicon containing this kind of impurity is called '**p-type**'.

A transistor is a sandwich of '**p-type**' and '**n-type**' silicon created in a single crystal.

It has three terminals, called 'collector', 'base' and 'emitter'.

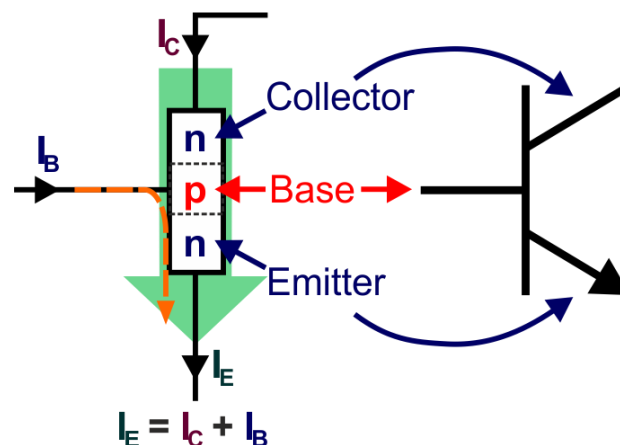

One version is the npn transistor, where the collector and emitter are '**n-type**' and the base is '**p-type**'.

A transistor is a current amplifier. A small current ( $I_B$ ) flowing into the base controls a much bigger current ( $I_C$ ) flowing into the collector. A small increase in base current can produce a large increase in collector current, and so on... . These two currents combine to make up the emitter current ( $I_E$ ).



# Adding a transistor amplifier

A sensing unit can be made more sensitive by adding a transistor amplifier.



DC

1. Build the layout shown below. It contains the temperature-sensing unit studied earlier, using a  $10\text{k}\Omega$  variable resistor. Its output is connected to a transistor amplifier.

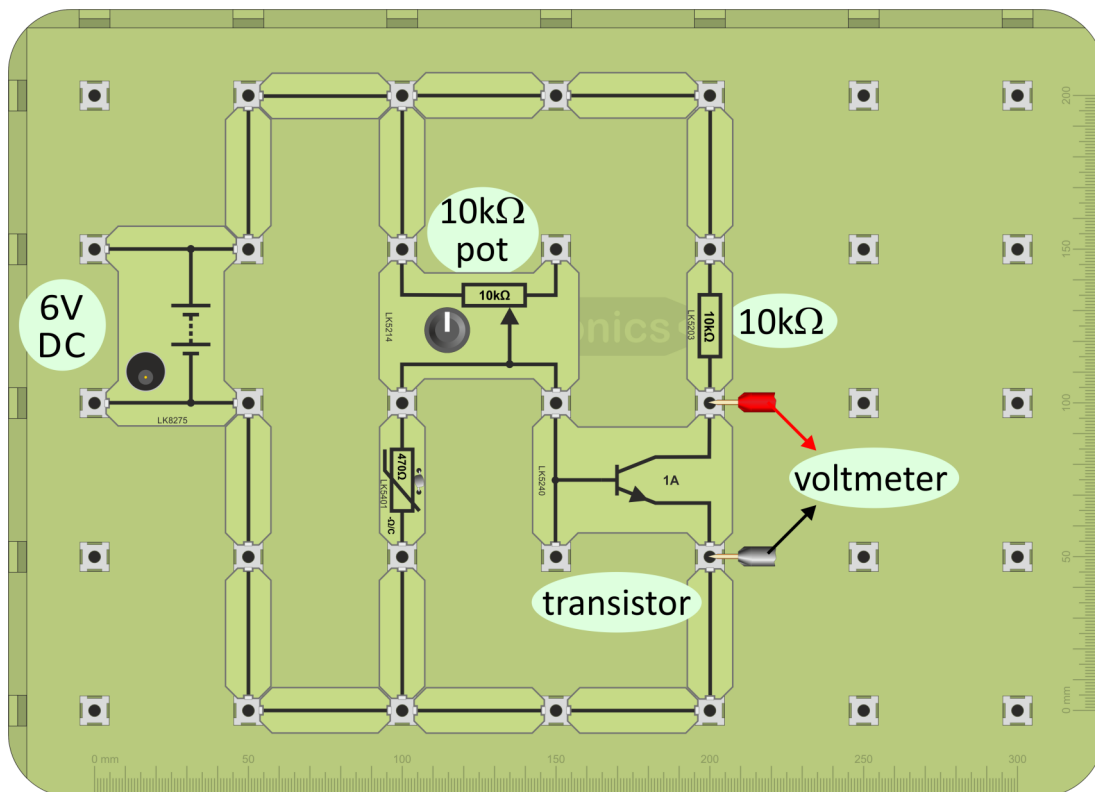

2. Connect a multimeter, set to read DC voltages up to 20V, to measure the output of the amplifier, as shown.
3. Set the DC power supply to 6V, connect it and switch on.
4. Adjust the variable resistor so that the output voltage is around 3V.
5. Warm up the thermistor between finger and thumb and watch the multimeter reading as you do so. It changes rapidly.
6. Connect the voltmeter across the thermistor so that you can compare this with the rate at which the output of the temperature-sensing unit changes.
7. Answer the question in the Student Handbook.

# A simple time delay circuit

Capacitors form the basis of a number of time-delay circuits.



DC

1. Build the layout shown below, an extension of the one you just used.



**Take care** to connect the capacitor the right way round!

The transistor acts as an electronic switch. It takes only a small current from the resistor-capacitor pair and so has little effect on the time delay.

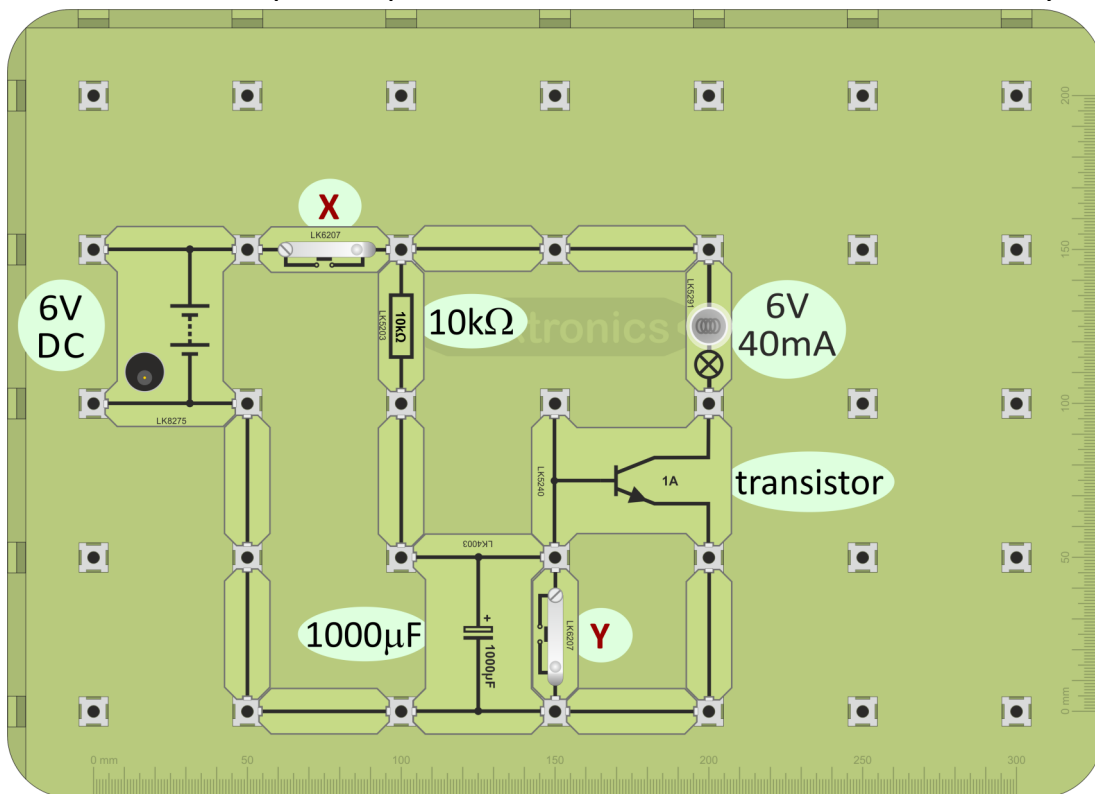

2. Press and hold down switch **X**. The bulb lights after a short delay.  
(Once again, to repeat the test, press switch **Y** to discharge the capacitor.)
3. Try other values of resistor and capacitor.
4. Answer the questions in the Student Handbook.

## Another simple time delay circuit

This uses a MOSFET (Metal-Oxide-Semiconductor-Field-Effect-Transistor), another type of transistor which draws an even smaller current from the resistor-capacitor network and can handle a higher load current. The diode offers protection against the high voltage, created when the motor is switched off ('back e.m.f.')



DC

1. Build the layout shown below. It is a modification of the one you just used - just swap the transistor for a MOSFET transistor and add the diode.

**Again - take care** to connect the capacitor the right way round!

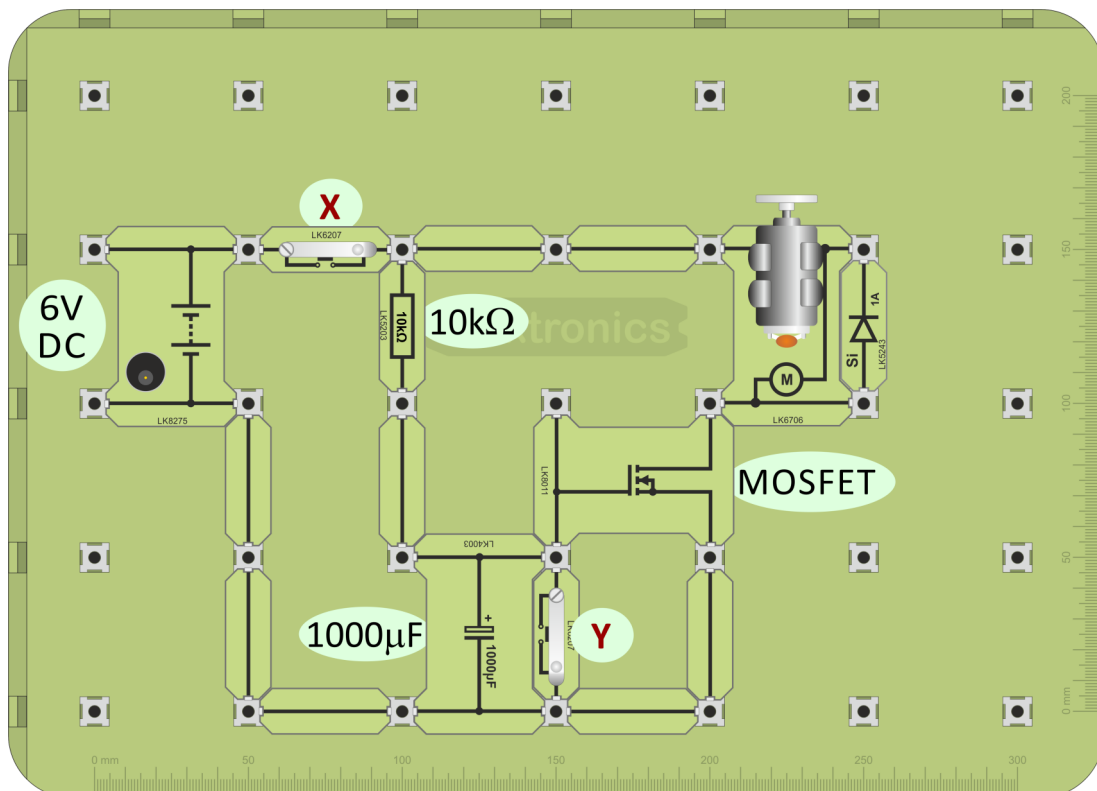

2. Press and hold down switch **X**. The motor starts to run after a short delay. (To repeat the test, first press switch **Y** which discharges the capacitor.)
3. Answer the questions in the Student Handbook.

# Soft-start motor circuit

The current in a DC motor is usually a maximum when power is first applied. A 'soft-start' circuit limits the initial current and torque as the motor turns on. This reduces mechanical wear-and-tear on the motor and gearbox and interference on the power supply. Usually, 'soft-start' circuits create a voltage ramp that starts the motor rotating slowly and then builds up. The next circuit illustrates one approach.



DC

1. Build the layout shown below. It is similar to the one you just used. The position of the motor and diode has changed. The circuit is now known as a 'source-follower'.

**Again - take care to connect the capacitor the right way round!**

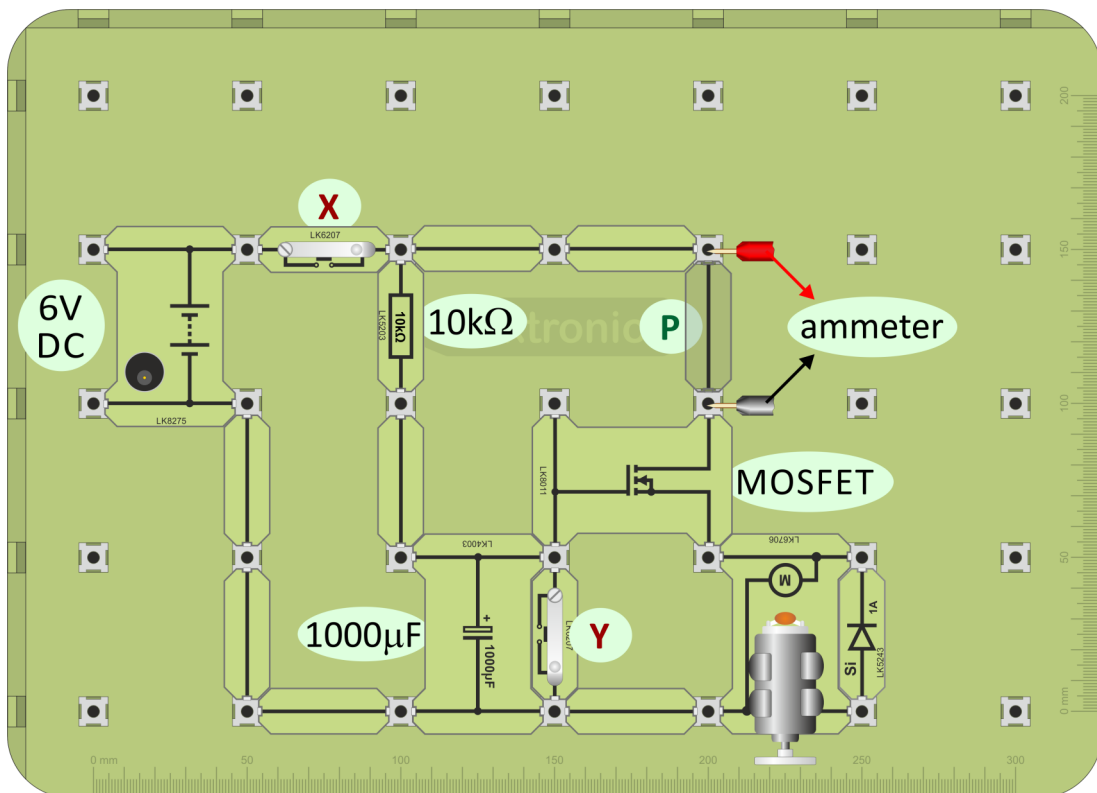

2. Press and hold down switch **X**. The motor starts off slowly and then speeds up. (To repeat the test, first press switch **Y** which discharges the capacitor.)
3. To see exactly what is happening, remove the connecting link labelled **P** and replace it with a multimeter, set up as an ammeter to measure up to 200mA. Press switch **Y** to discharge the capacitor and then hold down switch **X**. Watch how the current through the motor builds up slowly.
4. Answer the questions in the Student Handbook.

# Lamp dimmer - 1

Lamp dimmers are common devices in homes and offices. Turning the knob adjusts the brightness of the lamp(s) connected to it, by turning the spindle on a pot, housed behind it.

You saw earlier that a pot can control the brightness of a lamp, when connected either as a variable resistor or as a voltage divider. When connected as a variable

resistor, the resistance of the pot must be chosen so that the brightness of the lamp can be reduced to zero.

However, both methods waste energy. In the voltage divider, current flows through the resistance of the pot all the time, generating heat and wasting energy. When connected as a variable resistor, the same thing happens, unless the resistance is turned down to zero, i.e. the lamp is at full brightness.

A better way to control brightness is to switch the lamp on and off rapidly.



### Ideal switching device:

When **off**, its resistance is **huge**, so the current through it is  $\sim$ zero.  
When **on**, its resistance is **tiny**, so the voltage across it is  $\sim$ zero.

Look at the information in the two boxes! Putting this together shows that an ideal switching device dissipates no power. It wastes no energy.

### Electrical Power:

means energy converted every second.

$$\text{Power} = \text{current} \times \text{voltage}$$

The triac is a widely-used switching device. With three terminals, a gate, (the control terminal), MT1 and MT2 ('MT' = 'Main Terminal'), it can conduct current in either direction and so conducts AC.

Electrically controlled, it is normally off until the voltage applied to its gate terminal rises above a threshold around +0.7V or falls below a threshold around -0.7V. The gate current needed is tiny, a few milliamps. As a result, it dissipates very little power. When the AC voltage drops to zero, the triac turns off until the gate voltage reaches the other threshold.

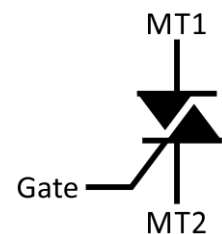



Usually, the gate voltage is created using 'phase control'.

We have seen that a capacitor takes time to charge up when connected in series with a resistor. In other words, the voltage across the capacitor lags behind the supply voltage. This is true in both AC and DC circuits.

The graph shows this lag in an AC circuit and the resulting behaviour on the triac.

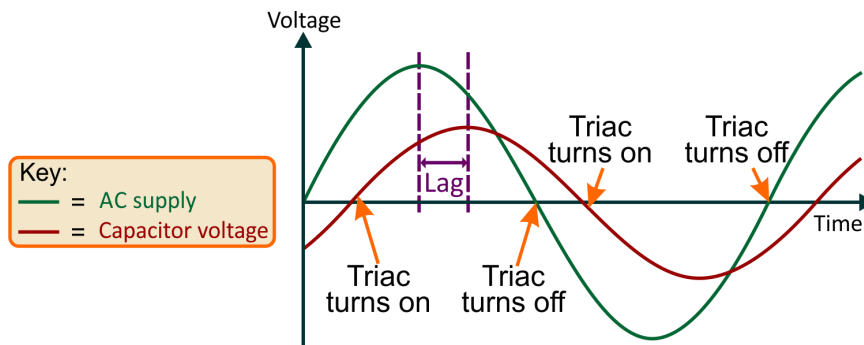

Connecting the voltage from the capacitor to the gate of the triac means that there is a delay, after the AC supply rises above (or below) 0V, before the triac switches on. When the AC voltage falls to zero, the triac, and lamp, turn off. Using a variable resistor, the delay (lag) can be varied and as a result, the lamp is switched on for longer / shorter in each cycle of the AC supply, varying its brightness.

Although not included in the circuit on the next page, it is common to find another semiconducting device connected in the gate circuit. This is the diac, a two terminal device. The diagram shows its circuit symbol.

Rather like two back-to-back zener diodes, it will conduct in either direction, but only once the supply voltage reaches a certain value, called the 'breakover' voltage.

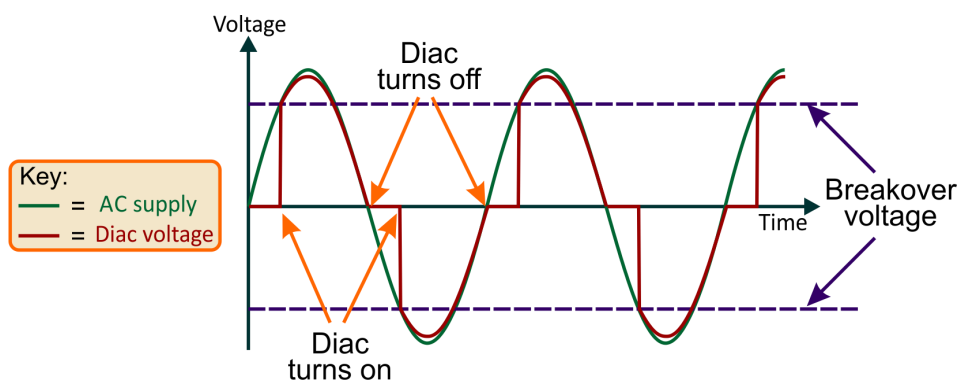

As the breakover voltage is typically around 30V, it is not possible to investigate them in low voltage circuits. Their benefits include reduced interference to power supplies and reduced triac heating, in high power systems, where the rapid turn-on offered by the diac reduces the average power dissipated in the triac.



1. Build the layout shown below.

The capacitor is non-electrolytic and can be connected either way round. Notice that the top-right terminal on the 10k pot is connected to an unused terminal on the triac. The only connection between them is that between the gate and the slider of the pot (lower right terminal.)

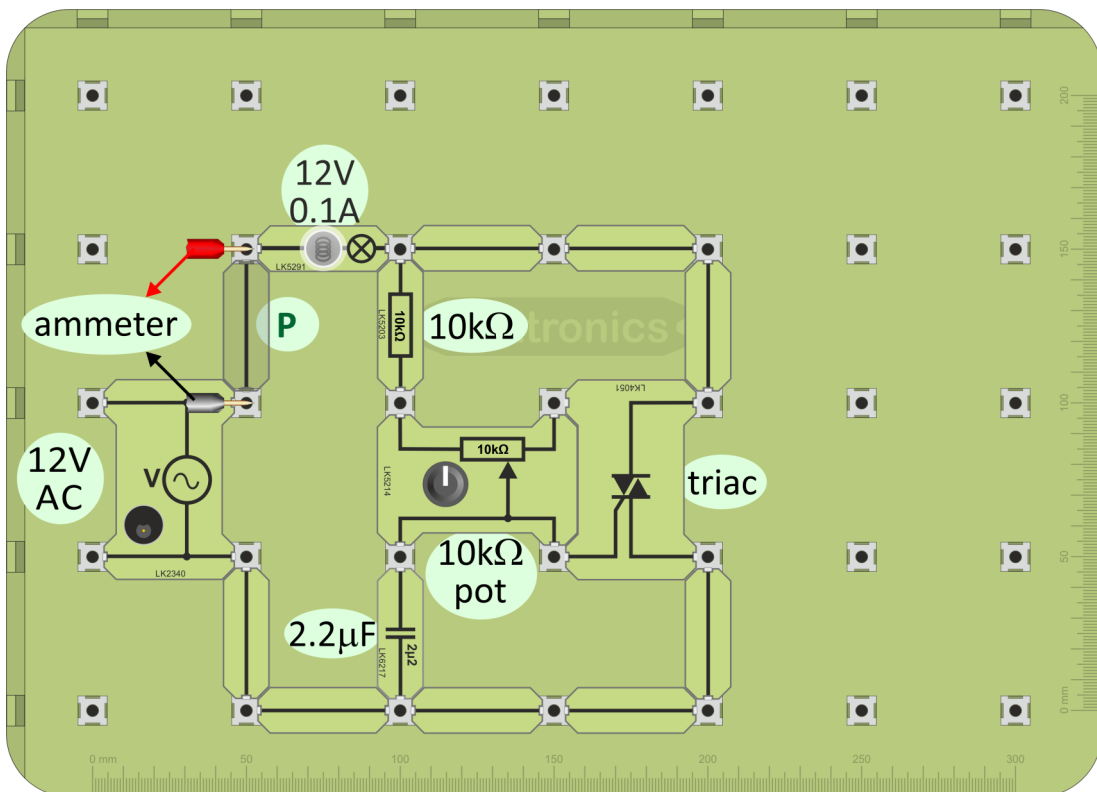

2. Turn the knob on the variable resistor and notice the effect on the brightness of the bulb.
3. To see the effect in more detail:
  - remove the connecting link labelled 'P';
  - replace it with leads from a multimeter set up as an ammeter to read AC current up to 200mA;
  - turn the knob on the variable resistor and watch the effect on the current through the lamp.
4. Answer the questions in the Student Handbook.

# **Electrical Installation Level 2**

## **Appendix**

-

# **Electrical measurements with a multimeter**

# Appendix 1 - measuring voltage



The picture shows one form of multimeter. It has a wide range of uses -which varies from model to model - but usually includes measuring AC and DC voltage and current

When using a multimeter, before you switch it on:

- take care to plug the probes into the correct sockets;
- select the correct range.

(‘Auto-ranging’ versions select the best range automatically.)

## Voltage:

- is a measure of the force pushing the electrons around the circuit;
- measures energy lost or gained as an electron moves through part of a circuit
- is measured with a voltmeter connected in parallel with the component.

The circuit symbol for a voltmeter is shown in the diagram.

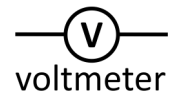

## Using a multimeter to measure voltage:

Multimeters can measure both AC and DC.

The following symbols distinguish between them:

- Plug one wire into the black ‘COM’ socket.
- Plug another into the red ‘V’ socket.
- Select the 20V DC range by turning the dial to the ‘20’ mark next to the ‘V’ symbol. (It is good practice to set the meter on a range that is much higher than the reading you are expecting. Then refine it by choosing a lower range to suit the voltage you find.)

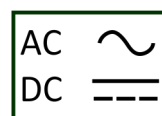

- Plug the wires into the sockets at the ends of the component under investigation.
- Switch on the multimeter when you are ready to take a reading.
- A ‘-’ sign in front of the reading means that the meter wires are connected the wrong way round. Swap them over to get rid of it!



When using a multimeter to measure current, plug the probes into the 'A' and 'COM' sockets, or equivalents.

Then select the correct range, either from the 'A~' section, for AC current or the 'A' section, for DC current.

Finally, switch on.

## Current:

- measures the number of electrons passing any point in the circuit each second;
- measures the rate of flow of electrical charge in the circuit;
- is measured with an ammeter connected in series with the component.

The circuit symbol for an ammeter is shown in the diagram.

## Using a multimeter to measure current:

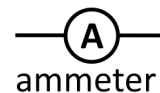

ammeter

- Plug one wire into the black 'COM' socket.
- Plug another into the red 'mA' socket.
- Select the 200mA DC range by turning the dial to the '200m' mark next to the 'A' symbol.

(Again, it is best to set the meter on a higher range to begin with. Then choose a lower range to suit the current you find.)

- Break the circuit where you want to measure the current, by removing a link, and then plug the two multimeter leads in its place.
- Switch on the multimeter when you are ready to take a reading.
- A possible problem:

The ammeter range is protected by a fuse located inside the body of the multimeter. This may have 'blown', in which case the ammeter will not work. Report any problems to your instructor so that it can be checked.



**When using a multimeter to measure resistance, the component must be removed from the circuit first!**

Once again, before you switch on:

- take care to plug the probes into the correct sockets, the ' $\Omega$ ' and '**COM**' sockets;
- select the correct range.

### Resistance:

- is a hindrance to the flow of electrons around the circuit;
- removes energy from each electron as it moves through the resistor;
- converts this energy into heat;
- is measured in units called 'ohms' (symbol - ' $\Omega$ ') or kilohms ( $k\Omega$ ), using an ohmmeter. (1 kilohm = 1 000 ohms.)

### Using a multimeter to measure resistance:

- Plug one wire into the black '**COM**' socket.
- Plug another into the red ' $\Omega$ ' socket.
- Turn the dial to select a resistance range, such as  $200k\Omega$ .  
(Once again, it is good practice to set the meter on a range higher than the reading you are expecting and then refine it to a lower range.)
- Make sure that the component under investigation is not connected to any other.
- Plug the wires into the sockets at the ends of the component.
- Switch on the multimeter when you are ready to take a reading.

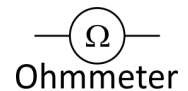



# **Electrical Installation Level 2**

## **Student Handbook**

-

# **For your records**

## Page 6 - AC or DC - which is used?

Electricity is usually generated and transmitted as AC because:

- alternators (AC) are usually more efficient than dynamos (DC);
- transformers, which work only on AC, can modify voltage and current efficiently.

Electronic devices - mobile phones, computers, televisions etc. usually require DC.

**AC power:** is converted into DC using the processes of rectification and regulation.

**DC power:** can be converted into AC using a device called an inverter.

### **DC power supplies:**

- **battery** - chemical reactions generate DC voltages, e.g. 'lead-acid' batteries;
- **solar cell** - photo-voltaic ('solar') cells convert light energy into DC electricity ;
- **dynamo** - a rotating coil of wire near a magnet generates DC using a 'commutator' to connect the coil to the rest of the circuit.

### **AC power supplies:**

- **alternator** - a coil of wire rotating near a magnet;
  - a 'slip-ring' connects to the rest of the circuit;
  - the coil can be driven by:
    - high-pressure steam, in a power station;
    - wind in a wind-generator;
    - falling water in a hydro-electric power station.

## Page 7 - AC or DC - does it matter?

Describe the effect of connecting a 12V DC motor to:

- a 12V DC power supply:

.....

.....

- a 12V AC power supply:

.....

.....

## Page 8 - The resistor:

We change the flow of electricity using a **resistor**.

For electrons, adding resistance is like asking you to run in mud.

It takes more energy!

What happened to the brightness of the lamp when you pressed the switch?



.....

Explain why this happened, using the words 'resistance' and 'current' in your answer:

.....

.....

## Page 9 - The capacitor:

A capacitor consists of two metal plates, separated by an insulating sheet, rolled up into a 'Swiss roll', in such a way that the metal sheets do not touch.

When powered, current flows from the power supply onto one plate and from the other plate back to the power supply, for a short time. This leaves one plate positively charged and the other negatively charged by the same amount.

The capacitor stores this charge until it can flow around a circuit.

Capacitors are rather like 'buckets' that store electric charge.

As they fill up, the voltage across them increases until they are fully charged (the 'bucket' is full.) The size of the 'bucket' is given by the capacitance, measured in units called farads (F). For most purposes, the capacitors used are much smaller, with values measured in microfarads ( $\mu$

F, - millionths of a farad) or smaller. The wider the bucket, the more water it takes to raise the level. The bigger the capacitance, the more electrical charge it takes to raise the voltage.

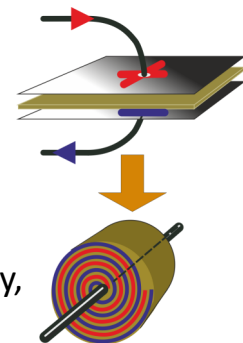

## Page 9 - The capacitor continued... :

Two 1 $\mu$ F capacitors  
electrolytic    non-electrolytic

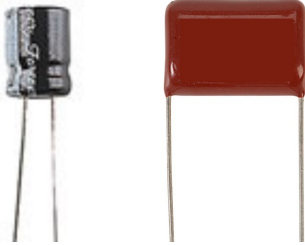

Capacitors come in two main types:

- electrolytic;
- non-electrolytic.

Electrolytic capacitors are polarised - with positive and negative terminals. They must always be connected the right way round. They cannot be used in AC circuits.

Non-electrolytic capacitors can be connected either way round, but are physically larger for a given value of capacitance.

### Take care!

As well as taking care to connect electrolytic capacitors the right way round, you need to check the 'working voltage' rating for the capacitor. This is the maximum safe voltage that can be used with it.

## Page 10 - Charging a capacitor:

How long did the capacitor take to charge up to 3V? .....

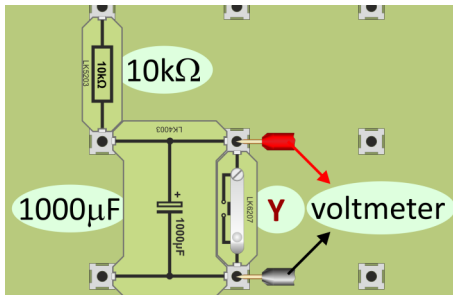

What happens to this time when you increase the size of the resistor?

.....  
.....

What happens to this time when you decrease the size of the capacitor?

.....

What happens when you press switch Y?

.....

Describe one important safety measure you need to take when building this circuit.

.....

.....

## Page 11 - The diode:

**Rectification** is the process used to turn AC into DC. It usually relies on the fact that current can flow only one way through a diode.

A diode has two terminals, known as the **anode** and the **cathode**.

The diagram shows a photograph of a common type of diode together with its circuit symbol.

The **cathode** is identified by a silver stripe on the body of the diode.

When the **anode** is more positive than the **cathode**, the diode is '**forward-biased**'.

When the **cathode** is more positive, it is '**reverse-biased**'.

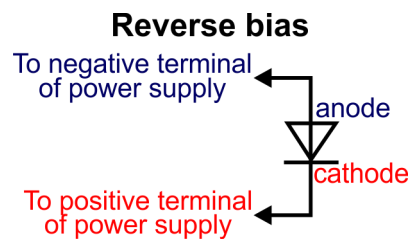
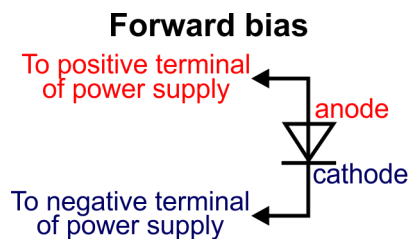
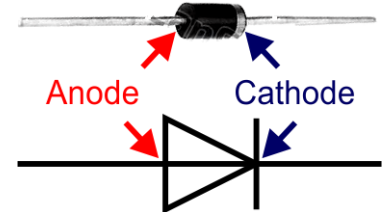

The diode acts as a 'one-way valve':

It allows current to flow through it **only** when it is forward-biased.

When reverse-biased, it does not conduct at all (for low voltages.)

## Page 12 - Rectification:

Explain to a fellow student how you know that the diode converts AC to DC:

.....

.....

.....

.....

.....

.....

## Page 13 - Low voltage DC power supply:

The aim is to convert a high-voltage (240V) AC mains supply into a low voltage (12V, typically) DC supply that can be used with electronic equipment.

This process can be divided into the stages, shown in the block diagram:

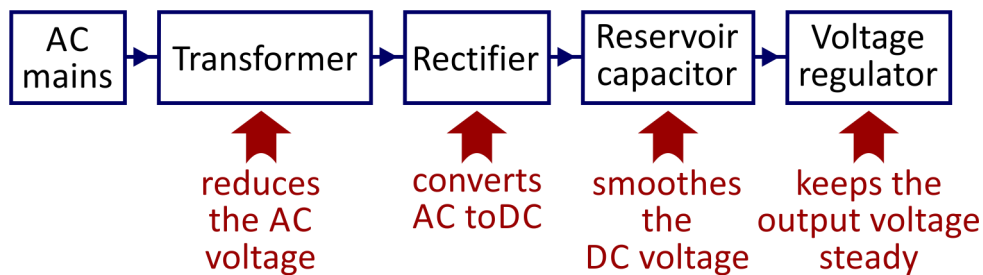

We have seen that a diode can be used as the rectifier and that a capacitor behaves rather like a bucket of charge, topping up the output when needed.

An ideal power supply maintains a steady voltage no matter what current is taken from it. The extent to which a real power supply achieves this is measured by a property called its **voltage regulation**.

**Zener diodes** are designed to 'break down' and conduct electricity at a particular value of reverse-bias voltage. They maintain that voltage for a wide range of currents. This makes them useful as voltage regulators in power supplies. The circuit symbol for a zener diode is shown in the diagram, together with the voltage that it tries to sustain when reverse-biased.

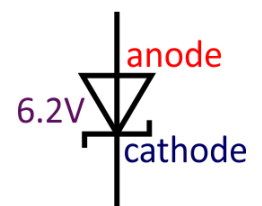

One form of voltage regulator consists of a resistor and zener diode in series with it. The zener diode is connected in reverse bias. The regulator in the diagram, using a 6.2V zener diode and a 100Ω resistor is designed to give an output voltage of 6.2V, leaving the rest of the input voltage across the resistor.

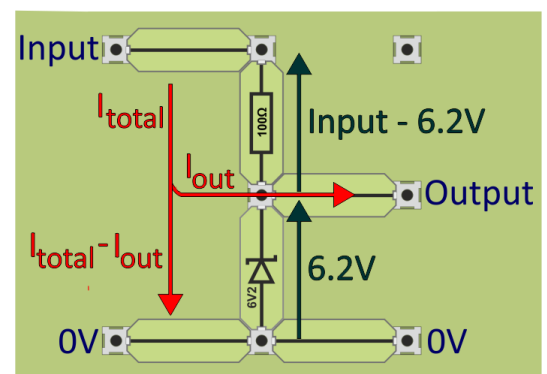

The current through the resistor divides between the output and the zener diode.

When the output current is zero, the full current flows through the zener diode. In this situation, the power dissipated in the zener diode is a maximum and the diode will be at its hottest.

## Page 14 The zener diode voltage regulator:

Describe what happens to the brightness of the bulbs as more and more bulbs are lit:

.....

.....

.....

What is the voltmeter reading when:

- no bulbs are lit; .....
- one bulb is lit; .....
- two bulbs are lit; .....
- three bulbs are lit. ....

## Page 15 - The LED:

The LED conducts only when forward-biased. Then some of the electrical energy is transformed into light. The filament lamp gets so hot that it glows. The LED creates light at low temperature, giving it a much higher energy efficiency.

The diagram shows a green LED with its circuit symbol. The **cathode** is usually the shorter leg. The colour of the light depends on the chemical elements used.

In the filament lamp (e.g. torch bulb) light is produced because the wire filament (usually tungsten) is heated to such a high temperature ( $\sim 2500^{\circ}\text{C}$ ) that it glows yellow hot.

To reduce evaporation of the metal, the glass envelope is filled with inert gas at low pressure.

Advantages of LEDs:

- lower energy consumption - no hot filament;
- longer lifetime - no expansion and contraction of the wire filament;
- physically robust - no glass envelope - no delicate filament;
- smaller size;
- faster switching.

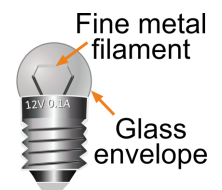
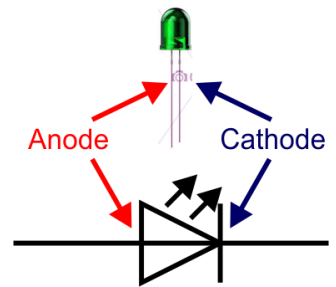



## Page 16 - Protecting the LED:

A typical LED cannot withstand more than about 3V under forward-bias and around 5V when reverse-biased.

A series resistor protects the LED when forward-biased.

When reverse biased, a diode, connected as shown in the diagram, can be used to protect it.

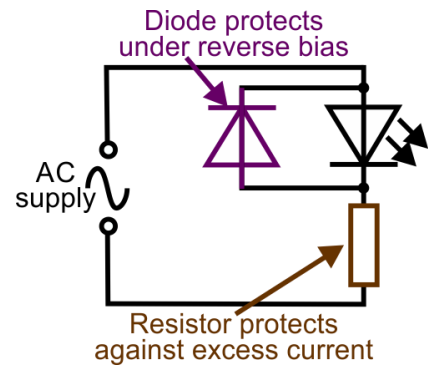

What is the purpose of the 1kΩ resistor in series with the LED?

.....

Explain **how** and **when** the diode connected in 'reverse-parallel' protects the LED:

.....  
.....  
.....

## Page 17 - Sensors:

What happens to the resistance of the thermistor when its temperature rises?

.....

What happens to the resistance of the LDR when the light level drops?

.....

## Page 18 - Temperature-sensing unit:

With the thermistor in its initial position, what happens to the output voltage when the temperature rises?

.....

How can you reverse this behaviour?

.....

## Page 19 - Light-sensing unit:

With the photodiode in the position shown in the diagram, what happens to the output voltage when the light level falls?

.....

Describe how you modified the circuit to reverse this behaviour?

.....

.....

.....

## Page 20 - The potentiometer structure:

The diagram illustrates the internal structure of a rotary potentiometer (pot).

When the spindle is rotated, a metal 'wiper' slides across a 'C'-shaped track, made from a carbon compound, or resistance wire.

The three terminals create two variable resistors:

- $R_A$ , between terminal **A** and terminal **C**;
- $R_B$ , between terminal **B** and terminal **C**.

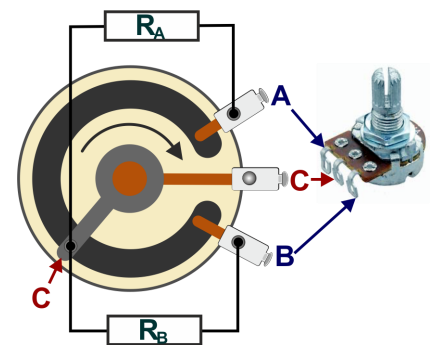

When the slider rotates, the length of track between the terminals changes, altering the resistance of the variable resistors.

When it moves clockwise in the diagram, for example,  $R_A$  gets smaller and  $R_B$  increases.

The resistance between **A** and **B** is the full resistance of the track and is fixed.

The pot is used in two ways:

- as a variable resistor, using only two terminals, either **A** and **C** or **B** and **C**;
- as a voltage divider, using all three terminals.

## Page 21 - Two ways to use a pot:

The upper diagram shows a pot used as a voltage divider - (all three terminals used.)

The lower diagram shows it used as a variable resistor. (Resistors have only two legs - so does this!)

Compare the effect of adjusting the pots in each case:

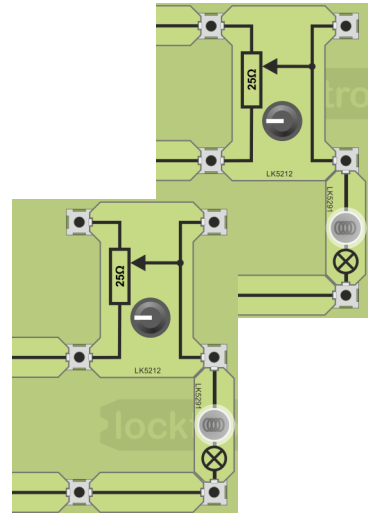

.....

.....

.....

.....

## Page 22 - Improved temperature-sensing unit:

A more flexible arrangement is to use a variable resistor in place of the fixed resistor, used in the earlier version.

With the knob turned fully clockwise, what was the output voltage?

.....

With the knob turned fully anti-clockwise, what was the output voltage?

.....

With the knob at the mid-position, what was the effect of warming up the thermistor?

.....

.....

## Page 23 - The transistor:

The transistor is made from a single crystal of a semiconducting material such as silicon. When pure, silicon does not conduct electricity very well - hence the name *semiconductor*. Its resistance falls markedly when selected impurities are added. It then conducts in a way that depends on the type of impurity added, either:

- using a 'sea' of free electrons, rather like a metal, such as copper; (This is called '**n-type**' as it conducts using free, **negatively-charged** electrons;)
- using electrons which are normally trapped in the silicon. (The impurities create 'holes' (missing electrons) in the crystal structure which behave as if they are **positively** charged. This is called '**p-type**'.)

A transistor is a sandwich of '**p-type**' and '**n-type**' silicon created in a single crystal.

It has three terminals, called 'collector', 'base' and 'emitter'.

One version, the npn transistor, has a collector and emitter made from '**n-type**' and the base from '**p-type**'.

A transistor is a current amplifier. A small base current ( $I_B$ ) controls a much bigger collector current ( $I_C$ ). A small increase in base current can produce a large increase in collector current, and so on... . These two currents combine to make up the emitter current ( $I_E$ ).

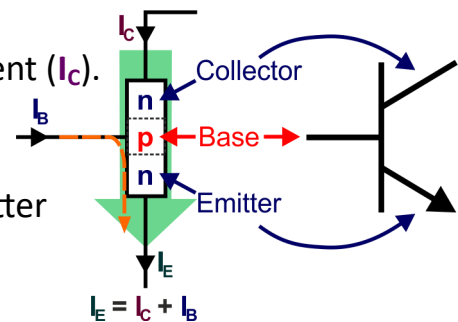

## Page 24 - Adding a transistor amplifier:

Describe the change in performance when a transistor amplifier is added to the output of the temperature-sensing unit.

.....

.....

.....

.....

.....

.....

.....

**Page 25 - A simple time delay circuit:**

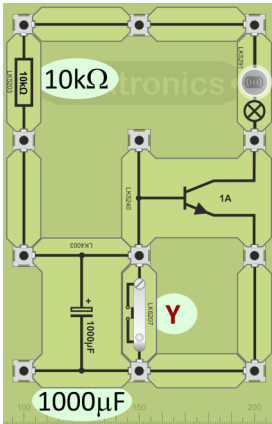

What is the advantage of adding a transistor to the resistor-capacitor network studied on the previous page?

.....

.....

.....

.....

Estimate the delay between pressing the switch and the lamp lighting. ....

Describe one modification to the circuit that makes this time delay longer.

.....

.....

**Page 26 - Another simple time delay circuit:**

What is the advantage of using a MOSFET in this application?

.....

.....

.....

.....

.....

.....

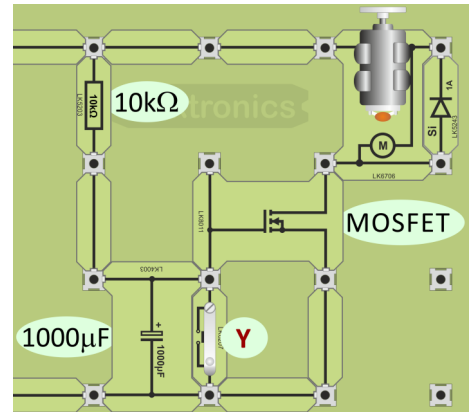

What is the purpose of the diode connected in parallel with the motor?

.....

How long was it before the motor started spinning? .....

Describe how to restart the timing process.

.....

.....

## Page 27 - Soft-start motor circuit:

How did the behaviour of the motor in this circuit differ from that in the circuit above?

.....

.....

.....

.....

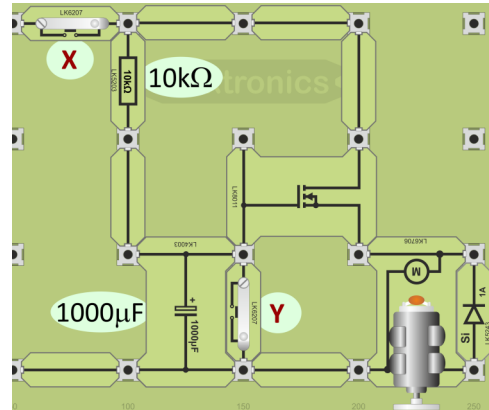

Why are there two switches, **X** and **Y**?

.....

.....

.....

.....

What is the job of the diode?

.....

## Page 28 - Lamp dimmer - 1:

**Ideal switching device:**  
When **off**, its resistance is **huge**,  
so the current through it is  $\sim$  zero.  
When **on**, its resistance is **tiny**,  
so the voltage across it is  $\sim$  zero.

**Electrical Power:**  
means energy converted every second.  
**Power = current x voltage**

One way to control the brightness of a lamp is to use a pot, connected either as a variable resistor or as a voltage divider. However, both ways waste energy as heat.

In the voltage divider, current flows through the resistance of pot all the time, generating heat .

As a variable resistor, the same thing happens, unless the resistance is zero, i.e. the lamp is at full brightness.

## Page 28 - Lamp dimmer - 1 continued...:

A better way to control brightness is to switch the lamp on and off rapidly using a triac. With three terminals, a gate, (the control terminal), MT1 and MT2 ('MT' = 'Main Terminal'), it can conduct current in either direction.

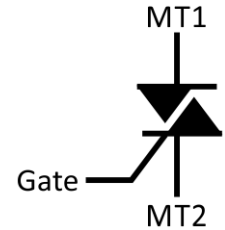

Electrically controlled, it is normally off until the voltage applied to its gate terminal rises above a threshold around +0.7V or falls below a threshold around -0.7V.

The gate current needed is tiny, a few milliamps. As a result, it dissipates very little power. When the AC voltage drops to zero, the triac turns off until the gate voltage reaches the other threshold.

Explain why no power is dissipated in an ideal switch.

.....

.....

.....

.....

.....

## Page 29- Phase control:

A capacitor connected in series with a resistor takes time to charge up. In other words, the voltage across the capacitor lags behind the supply voltage. The graph shows this lag in an AC circuit and the resulting behaviour on the triac.

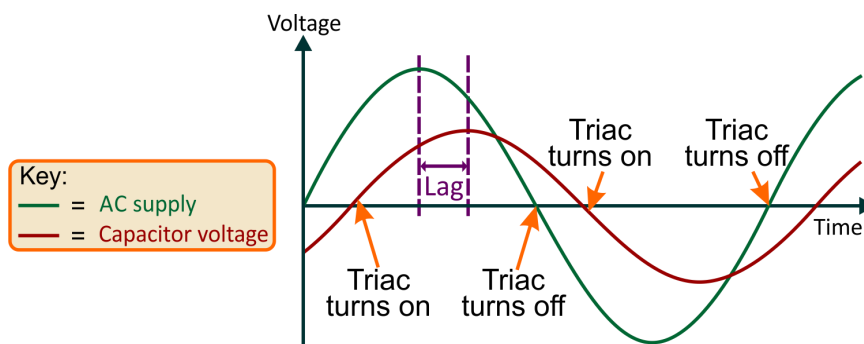

Connecting the voltage from the capacitor to the gate of the triac means that there is a delay, after the AC supply rises above (or below) 0V, before the triac switches on. When the AC voltage falls to zero, the triac, and lamp, turn off. Using a variable resistor, the delay (lag) can be varied and as a result, the lamp is switched on for longer / shorter in each cycle of the AC supply, varying its brightness.



## Page 29- Phase control continued... :

It is common to find another semiconducting device, the diac, connected in the gate circuit. The diagram shows its circuit symbol.

Rather like two back-to-back zener diodes, it conducts in either direction, but only once the supply voltage reaches the 'breakover' voltage, typically around 30V.

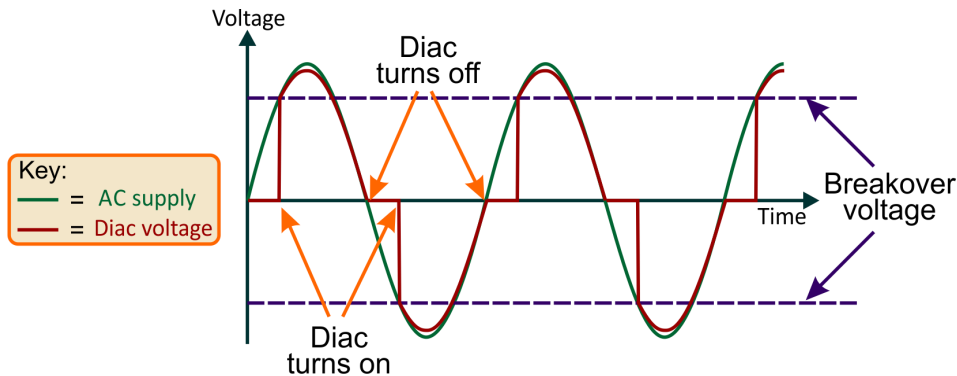
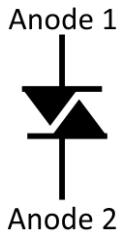

Their benefits include reduced interference to power supplies and reduced triac heating, in high power systems, where the rapid turn-on offered by the diac reduces the average power dissipated in the triac.

## Page 30 - Lamp dimmer - 2:

The capacitor is non-electrolytic and can be connected either way round. The top-right terminal on the pot is connected to an unused terminal on the triac. The only connection between them is that between the gate and the slider of the pot (lower right terminal.)

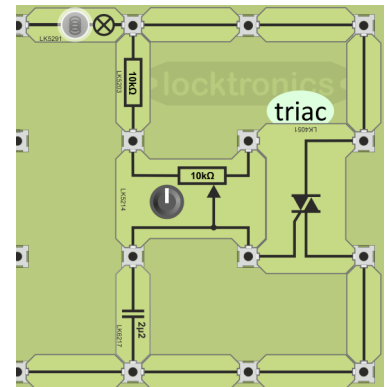

What is the effect of turning the pot spindle clockwise?

.....

What is the maximum and minimum current through the bulb?

.....

# Instructor Guide

## About this course

### Introduction

The course is essentially a practical one. It highlights some applications of a range of common electronic components.

Locktronics equipment makes it simple to construct and test electrical circuits. Layouts are used to create functioning circuits for the student to investigate.

A Student Handbook is included to give students a concise record of their studies.

### Aim

The course introduces students to a range of components found in domestic and industrial electrical installations.

It covers much of the content of the City and Guilds Level 2 Certificate in Electrical Installations, Unit 202, focussing on the contents of Topic 4 “Understanding Electronic Components”, and forms the basis for further study of this topic.

### Prior Knowledge

The student should have basic mathematical skills sufficient to calculate a required quantity from a given formula. No manipulation of formulae is expected.

They should have followed the Matrix LK 4098 “Electrical wiring 1” course, or should have equivalent knowledge and experience of electricity and electrical wiring installations.

### Progression

This course leads into the City and Guilds Level 3 Advanced Technical Diploma in Electrical Installations. Some of which is covered in modules such as the Matrix ‘Three Phase Systems’ course, LK2686, which includes manipulating phase, star and delta configurations, power factor and its correction and the implications of balanced and unbalanced loads.

### Using this course:

The experiments in this course should be integrated with relevant teaching to support the theory behind them, and reinforced with practical examples and assignments.

The activities should be printed / photocopied / laminated, preferably in colour, for the students’ use. They are unlikely to need their own permanent copy of them. The Student Handbook should be made available at the outset, so that students can complete it with their measurements and observations as they progress through the course and then keep it for their records.

The format of the course encourages self-study, with students working at a rate that suits their ability. The instructor should monitor that students’ understanding keeps pace with progress through the worksheets. One way to do so is to ‘sign off’ each activity, as a student completes it, and in doing so have a brief chat with the student to assess grasp of the ideas involved in the exercises it contains.

### Time allocation:

It should take students between 8 and 10 hours to complete the activities.

A similar length of time will be needed to support the learning that takes place as a result.

## Learning Objectives















On successful completion of this course the student will be able to:

- distinguish between AC and DC power;
- name the processes involved in converting an AC power supply into a DC power supply;
- name one common source of DC power;
- name one common source of AC power;
- describe what is meant by 'electrical resistance' and its effect on the current flowing in a circuit;
- describe the structure of a capacitor;
- recall that capacitance is measured in units called farads (F);
- distinguish between electrolytic and non-electrolytic capacitors;
- recall the circuit symbol for a diode;
- name the terminals on a diode;
- explain the meaning of the terms 'forward' bias and 'reverse' bias;
- state the conditions required for a diode to conduct current;
- set up a diode to rectify an AC power supply;
- distinguish between the electrical behaviour of a power diode and a zener diode;
- draw a block diagram for a low voltage power supply;
- describe what is meant by voltage regulation;
- set up and investigate a simple voltage regulator using a zener diode and a series resistor;
- recall the symbol for a LED;
- identify the terminals of a leaded LED;
- state five advantage of an LED over a filament lamp when used as an indicator;
- describe the use of a resistor to protect a LED from excessive current;
- describe the use of a silicon diode to protect a LED against an excessive reverse voltage;
- investigate the effect of temperature change on the resistance of a thermistor;
- investigate the effect of a change in light intensity on the resistance of a LDR;
- set up a temperature-sensing unit using a thermistor in a voltage divider;
- set up a light-sensing unit using a photodiode in a voltage divider;
- describe the structure of a potentiometer;
- distinguish between the use of a pot as a variable resistor and as a voltage divider;
- set up a pot as a variable resistor to control the brightness of a lamp;
- set up a pot as a voltage divider to control the brightness of a lamp;
- use a variable resistor to add flexibility to a temperature-sensing unit;
- outline the differences between n-type and p-type silicon;
- describe the behaviour of a npn transistor as a current amplifier;
- state one advantage of adding a DC-coupled transistor amplifier to the output of a temperature-sensing unit;
- describe the use of a RC network as a time-delay subsystem;
- adjust the delay produced by changing the values of the resistor and capacitor;
- describe the reason for adding a transistor amplifier to the output of a RC network;
- give one advantage of using a MOSFET in an amplifier circuit over using a npn transistor;
- explain the meaning of the term 'soft-start' applied to DC motor control;
- explain why a perfect switch does not dissipate electrical energy;
- recall the symbol for a triac;
- name the three terminals of a triac;
- outline the behaviour of a triac as an electronic switch;
- describe what is meant by 'phase control';
- use voltage-time graphs of the AC supply and capacitor voltage to predict when a triac turns on and off;
- recall the symbol for a diac;
- recall the benefits of using a diac in a phase control network to trigger a triac;
- set up a multimeter to measure the voltage across a component;
- set up a multimeter to measure the current through a component;
- set up a multimeter to measure the resistance of a component.

## What the student will need:

To complete the course, the student will need the following equipment:

1	HP2045	Shallow tray
1	HP2666	DC power supply
1	HP3728	AC power supply
2	HP4039	Tray lid
1	HP5540	Deep tray
2	HP7750	Daughter tray foam cut out
2	HP8600	Crash foam
2	HP9564	62mm daughter tray
1	LK2340	AC voltage source carrier
1	LK2346	MES bulb 12V, 0.1A
3	LK2347	MES bulb 6V, 0.06A
1	LK4002	Resistor - 100 ohm, 1W, 5% (DIN)
1	LK4003	Capacitor 1000 microfarad
1	LK4025	Resistor - 10 ohm,, 1W, 5% (DIN)
1	LK4051	Triac
1	LK5202	Resistor, 1k, 1/2W, 5% (DIN)
1	LK5203	Resistor, 10k, 1/2W, 5% (DIN)
1	LK5212	Resistor - variable 25 ohm
1	LK5214	Resistor - variable, 10k ohm
1	LK5249	Diode silicon
15	LK5250	Connecting Link
1	LK5253	Zener diode, 6.8V
3	LK5291	Lampholder carrier
1	LK5401	Thermistor 470 ohm
1	LK5603	Lead - red - 4mm to 4mm stackable
1	LK5604	Lead - black - 4mm to 4mm stackable
2	LK5609	Lead - blue - 4mm to 4mm stackable
1	LK6200	Resistor, 1M, 1/4W, 5% (DIN)
2	LK6207	Switch, push to make
1	LK6217	Capacitor 2.2 microfarad
1	LK6635	LED, red
1	LK6705	Power transistor npn
1	LK6706	Motor 3V to 12V DC
1	LK7361	Photodiode
1	LK8011	Power MOSFET transistor
1	LK8275	Power supply carrier with battery symbol
1	LK8900	Baseboard

Page	Notes for the Instructor	Timing														
<p>3 Introduction</p>	<p>The course aims to prepare students for topic 4 of Unit 202 - “Electrical Science”, part of the City and Guilds Level 2 Technical Certificate in Electrical Installations . It follows on from the Level 1 course (LK4098).</p> <p>It uses both AC and DC power supplies so that the students is familiar with both and includes a comparison of their performance. By default, activities use the AC supply, as in most domestic and industrial installations. At times, the DC power supply is used either because the investigation involves instrumentation, or because of the nature of the investigation.</p> <p>The layouts show the student how to build the systems and include an appropriate type of power supply carrier, sometimes AC and sometimes DC. Often, this choice is optional and icons are used to identify which type of power supply can be used.</p> <p>Icons are used to show the kind of activity being undertaken:</p> <table border="1" data-bbox="432 981 1166 1503"> <thead> <tr> <th data-bbox="437 987 584 1048">Icon</th> <th data-bbox="587 987 1161 1048">Significance</th> </tr> </thead> <tbody> <tr> <td data-bbox="437 1052 584 1128"></td> <td data-bbox="587 1052 1161 1128">Content gives information about electricity, or explains some terminology</td> </tr> <tr> <td data-bbox="437 1133 584 1207"></td> <td data-bbox="587 1133 1161 1207">Practical activity</td> </tr> <tr> <td data-bbox="437 1211 584 1285"></td> <td data-bbox="587 1211 1161 1285">Relates the current activity to jobs in the industrial / domestic realm</td> </tr> <tr> <td data-bbox="437 1290 584 1364"></td> <td data-bbox="587 1290 1161 1364">Open-ended activity where the students designs the activity</td> </tr> <tr> <td data-bbox="437 1368 584 1442"></td> <td data-bbox="587 1368 1161 1442">Health and Safety related issue</td> </tr> <tr> <td data-bbox="437 1447 584 1503"></td> <td data-bbox="587 1447 1161 1503">Activity involves a formula or calculation</td> </tr> </tbody> </table>	Icon	Significance		Content gives information about electricity, or explains some terminology		Practical activity		Relates the current activity to jobs in the industrial / domestic realm		Open-ended activity where the students designs the activity		Health and Safety related issue		Activity involves a formula or calculation	
Icon	Significance															
	Content gives information about electricity, or explains some terminology															
	Practical activity															
	Relates the current activity to jobs in the industrial / domestic realm															
	Open-ended activity where the students designs the activity															
	Health and Safety related issue															
	Activity involves a formula or calculation															
<p>4 Circuit training</p>	<p>The first activity is marked ‘optional’.</p> <p>Students who are familiar with the Locktronics system can omit this.</p> <p>For new students, the activity is important, partly in building confidence - many people have serious misgivings about anything electrical - they can’t see how it works, worry about electric shocks etc., partly to impart enjoyment and challenge and partly to introduce the Locktronics kit.</p> <p>Throughout the course, activities are designed to mirror the tasks and experiences that the students will find in their working lives.</p> <p>The instructor should add anecdotes from their experience to enrich these activities.</p>	<p>15 - 20 mins</p>														

Page	Notes for the Instructor	Timing
5 Power Supplies - 1	<p>This section introduces the two types of electrical power, AC and DC, through voltage / time graphs. Some students may not have sufficient mathematical experience to appreciate their significance. In that case, the instructor may need to spend time working through other examples.</p> <p>The section also mentions that oscilloscopes can be used to produce these graphs. The instructor could demonstrate this, though students themselves are not expected to have any understanding or expertise in using an oscilloscope at this stage.</p>	10 - 15 mins
6 Power Supplies - 2	<p>This section provides outline information about the role of the power supply, e.g. the plug-top devices used in these activities or the National Grid in domestic installations and explains the need for both.</p> <p>At this stage, there is no need for detailed information about electricity generation, but the instructor may wish to point out that the alternator, an AC generator, whether driven by steam, water, wind or whatever is usually more efficient than the equivalent DC generator.</p> <p>Transformers will not work on DC. They have the ability to step-up or step-down voltage and current very efficiently. Both of these factors argue in favour of generating electricity in AC form.</p> <p>The remainder of this page looks at common sources of AC and DC power, pointing out that each can be converted into the other.</p> <p>The instructor could support this section using examples of electricity sources - batteries, solar cells, alternators etc.</p>	10 - 15 mins
7 AC versus DC - 1	<p>The activity shows that choice of AC or DC can be crucial. The first part shows that the DC motor works properly on the DC supply, as its name suggests. However, on AC, the motor twitches backwards and forwards in step with the AC power. At this point, consideration of the resistor is important. As the motor is not rotating, there is no 'back e.m.f.' generated to oppose the applied voltage and reduce the current flowing. The current is high enough to damage the motor. The resistor reduces the current. (Students are not expected to appreciate the finer points of this explanation!)</p>	20 - 30 mins
8 The resistor	<p>The next three sections introduce components that play significant roles in power supplies - the resistor, the capacitor and the diode.</p> <p>The introduction to this section likens the effect of electrical resistance on electrons to running in mud. Increased 'friction' - electrons colliding with and losing energy to surrounding atoms - results in the generation of heat.</p> <p>The experiment contrasts the case where the current must flow through the bulb AND the 10Ω resistor with that where the switch is pressed to 'short-circuit' the resistor. The actual resistance used is not important except that if it is too big, it will cut the current to such a low value that the bulb will not glow. Then the student has no way of distinguishing this situation from a break in the circuit.</p>	15 - 20 mins



Page	Notes for the Instructor	Timing
<p>9 The capacitor</p>	<p>The section begins with a description of the 'parallel-plate' capacitor and a of how it operates as a charge store. The circuit symbol and unit of measurement, the farad, are included.</p> <p>The comparison with a bucket, in a water circuit, is a useful one worth developing. For instance:</p> <ul style="list-style-type: none"> <li>• The water level In the bucket does not change rapidly, especially if the bucket is a large one.</li> <li>• The bigger the current of water, the faster the bucket fills, the bigger the electric current, the faster the capacitor charges.</li> <li>• In reality, capacitors act like leaky buckets. The insulator is not perfect and a tiny current flows through it, slowly discharging the capacitor.</li> </ul> <p>Capacitors can be physically large components - an issue as electronic circuits become smaller and smaller. In an effort to address this, the electrolytic capacitor was developed. The thickness of the insulating sheet is reduced to almost atomic dimensions by activating a chemical reaction inside the capacitor which deposits a thin layer of an insulator such as aluminium oxide on one of metal plates.</p> <p>However, the result is a polarised component - one which can be connected only one way round. One consequence of this is that electrolytic capacitors cannot be used in AC circuits.</p>	<p>10 - 15 mins</p>
<p>10 Charging a capacitor</p>	<p>The description of how a capacitor charges up is now put to the test. Straight away, there is the issue of connecting the electrolytic capacitor the right way round. A large value capacitor (big bucket) is used so that the charging process is observably slow. The instructor must watch to ensure that students assemble the circuit correctly.</p> <p>Pressing switch Y allows the student to reset the system to view the charging process again. It creates an easy (low resistance) path for the electric charge stored on one plate of the capacitor to flow to the other plate, discharging the capacitor.</p> <p>By using other values of resistor and capacitor in this circuit, the student should realise that the bigger the resistor / capacitor, the longer it takes for the capacitor to charge.</p>	<p>20 - 30 mins</p>
<p>11 The diode</p>	<p>The route taken by the module now heads towards rectification - converting AC into DC. Hence the introduction of the diode - a device that allows current to flow in only one direction through it. Students may need to be given clarification about what is meant by AC and DC. In AC, the current flows one way and then the other. The size of the current is not important. In DC, the current only flows in one direction. It may vary in size, but if it flows in the same direction all the time, it is DC.</p> <p>This section includes the circuit symbol for the diode and the names of its terminals. The idea of forward and reverse bias is also discussed, though this may need reinforcement from the instructor.</p>	<p>10 - 15 mins</p>

Page	Notes for the Instructor	Timing
<p>12 Rectification</p>	<p>This section uses the behaviour of the motor to judge whether the power supply is AC or DC. We have just seen that the motor only twitches when the supply is AC.</p> <p>The diode, discussed in the previous section prevents the current from flowing in two directions and hence converts the AC to DC. (It is more accurate to say that the diode offers a large resistance to the flow of current in one direction (the 'reverse' direction) but a small resistance to flow in the other (the forward direction). It is probably too early in the course to load the discussion with this level of detail.)</p> <p>At this stage it is not steady DC. Its size grows and shrinks but it always flows in the same direction. This direction is indicated by the arrow built into the circuit symbol. The fact that the motor rotates shows that it is DC.</p>	<p>20 - 30 mins</p>
<p>13 Low voltage DC power supply</p>	<p>So far, the focus of the course has been on power supplies.</p> <p>Now the student is presented with a block diagram showing the main sub-systems of a low voltage DC power supply, with a brief description of their roles.</p> <p>The idea of voltage regulation is introduced. There are two aspects to this - line regulation, where the output voltage should stay constant when the mains supply voltage changes and load regulation, where the output voltage is immune to changes in load current. It is the latter that this section addresses using a zener diode.</p> <p>Students should realise that all diodes have a 'break-down' voltage. For power diodes, this is kept as high as possible, usually hundreds of volts. By manipulating the production process, this voltage can be controlled to produce diodes that break-down at a predictable reverse voltage.</p> <p>This break-down does not damage the diode provided that the resulting current is kept under control. In normal use, some current flows to the output. The final point made here is that zener diodes are under most stress when there is no output current. Then all the current flows through and heats up the zener diode.</p>	<p>10 - 15 mins</p>
<p>14 The zener diode voltage regulator</p>	<p>The aim is to illustrate the significance of load regulation.</p> <p>To begin with, the circuit is assembled but the MES bulbs are left unscrewed so that they do not light. The multimeter is used to read the output voltage of the voltage regulator.</p> <p>In turn, one, two and then three bulbs are screwed into their holders, making them light. In the process, the output current from the voltage regulator increases. Where voltage regulation works, the addition of extra bulbs has no effect on brightness or the output voltage. With the addition of the third bulb, however, the output current exceeds the design value and the output voltage falls, shown by the dimming of the bulbs and by the multimeter reading.</p>	<p>20 - 30 mins</p>

Page	Notes for the Instructor	Timing
15 The LED	<p>The LED shows the same ‘one-way conduction’ as the power diode. However, that is not its speciality. When it passes a current some of the electrical energy is converted to light. The colour of the light is not achieved by coloured filters but comes directly from the subatomic processes taking place. It depends on the chemical mix used to create it.</p> <p>Most importantly, it happens at low temperature. By contrast, in the traditional filament bulb, the current flowing through the resistance of the filament heats it to such a high temperature that it glows yellow-hot. The point is, however, that most of the electrical energy is transformed into heat in raising the temperature of the filament.</p> <p>The text highlights the advantages of the LED over the filament lamp, when used as an indicator in electronic systems.</p>	10 - 15 mins
16 Protecting the LED	<p>The introduction spells out the problem - the LED is damaged by high forward or reverse voltages. It goes on to look at ways to protect the LED - a series resistor to reduce the current when forward biased, and a power diode to protect it from high reverse voltages.</p> <p>The role of the resistor can be looked at in terms of a voltage divider. The resistor and LED share the supply voltage in such a way that the LED is not exposed to a voltage high enough to damage it.</p> <p>The worksheet includes the first circuit diagram. Students have seen the symbols earlier but may need help to interpret the circuit diagram itself.</p>	20 - 30 mins
17 Sensors	<p>This section introduces two specialised forms of resistor, one light-dependent, (LDR,) the other temperature-dependent, (thermistor). Actually, all resistors are temperature -dependent. Normally, their resistance increases with temperature. The one used here is the ‘n.t.c.’ version (negative temperature coefficient.)</p> <p>The task is to use a multimeter to monitor the change in resistance of the device when light-level / temperature changes. Help with using a multimeter to measure resistance is given in the Appendix.</p> <p>Caution - most LDRs contain lead or cadmium and are not RoHS (Restriction of Hazardous Substances) compliant. Instructors must decide whether this part of the investigation should be carried out. (The worksheet that follows shortly uses a photodiode which is not subject to the same restrictions.)</p>	20 - 30 mins
18 Temperature sensing unit	<p>Here is a sensing unit that feeds information into an electronic system about external conditions.</p> <p>The thermistor is now connected with a resistor in a voltage divider. By monitoring the output voltage - across the resistor in this case, students observe that temperature changes lead to a change in this voltage.</p> <p>Electronic systems are very logical - turning the sensing unit upside down, by swapping over the thermistor and resistor, turns its behaviour upside-down.</p> <p>Students need have no worries about touching the thermistor! The circuit operates at a low and very safe voltage.</p>	20 - 30 mins

Page	Notes for the Instructor	Timing
<p>19 Light Sensing unit</p>	<p>This investigation mirrors the previous one but sets up a light-sensing unit, using a photodiode. This is a silicon-based photodiode and as such is RoHS compliant.</p> <p>It is connected in reverse bias. Light falling on the diode releases free electrical charges, creating a small current. A large value resistor is needed to create a measurable voltage with such a small current.</p> <p>Students are challenged to modify the circuit to invert the behaviour. The previous exercise with the temperature-sensing unit provides a clear hint as to how to achieve this. The instructor should, however, check that the photodiode is still connected in reverse bias.</p>	<p>20 - 30 mins</p>
<p>20 The potentiometer structure</p>	<p>This page examines the working of a common device, the potentiometer, usually called the pot. Its use is widespread across an extensive range of applications. Students could be tasked with listing occurrences in home or work environments.</p> <p>If possible, a partly-dismantled pot should be available for students to examine. Students could use a multimeter to measure the resistance between pairs of its terminals to see the effect of rotating the spindle.</p> <p>There is common misunderstanding about the use of the pot in its two roles as variable resistor and as voltage divider.</p> <p>The first point to emphasise is that, in the same way that resistors have two legs, so do variable resistors. Similarly, voltage dividers have three connections - the two power supply connections and the output connection from the mid-point of the voltage divider.</p> <p>A possible area of confusion is the way the Locktronics pot is set out. It appears to have four connections, as it uses a carrier with four terminals. The instructor should ensure that students realise that two of these terminals are joined together. Again, a multimeter can be used to investigate what happens to the resistance between pairs of terminals when the spindle is rotated.</p>	<p>10 - 15 mins</p>
<p>21 Two ways to use a potentiometer</p>	<p>The issues raised on the previous page are investigated experimentally. Students should examine the two layouts closely to see how they differ. The instructor may need to check that the layouts are correct!</p> <p>The variable resistor offers different values of resistance to control the current through the lamp. The voltage divider adjust the power supply voltage delivered to the lamp.</p> <p>The value chosen for the resistance of the pot is important. As a variable resistor, too big a value would not give gradual control to the brightness - it would almost be on / off. Too small a value would not offer significant control over brightness. As a voltage divider, the rule of thumb that says that the current taken by the load (the lamp) should be at least ten times smaller than the current through the voltage divider itself. Otherwise, the load current would adversely affect the output voltage.</p> <p>The lamp passes a current of 100mA. Even with the 25Ω pot, having a current of 480mA through the voltage divider, this requirement is not met.</p>	<p>25 - 35 mins</p>

Page	Notes for the Instructor	Timing
<p>22 Improved temperature sensing unit</p>	<p>One problem with the earlier version of temperature-sensing unit is that the 'normal' output voltage cannot be adjusted. It might be too high or too low for the purpose in hand.</p> <p>This layout adds more flexibility by replacing the fixed resistor with a variable, using a pot. The students investigate the range of output voltages possible with this arrangement and check that it is still affected by temperature change.</p>	<p>20 - 30 mins</p>
<p>23 The transistor</p>	<p>Ultimately mysterious, the inner working of the transistor is beyond the scope of this course. Students should regard it as a 'black box' that amplifies signals.</p> <p>They are given the names of the terminals and the circuit symbol.</p> <p>Beyond that, there is a brief description of its functionality as a current amplifier. Even that is beyond the course requirements. The instructor, knowing the students, will judge how far to take this explanation</p>	<p>10 - 15 mins</p>
<p>24 Adding a Transistor amplifier</p>	<p>The important bit! Using amplification increases the sensitivity of the temperature- sensing unit, meaning that the output voltage changes more, for a given temperature rise.</p> <p>This should be apparent when the student compares the rate of voltage change at the output of the temperature-sensing unit with that at the output of the transistor amplifier.</p> <p>The layout makes use of the two connected terminals on the pot carrier to transfer the output signal from the sensing unit to the input of the transistor amplifier.</p>	<p>25 - 35 mins</p>
<p>25 A simple time delay circuit</p>	<p>Although the previous circuit demonstrates the principle of time delay circuits - pressing a switch results in a slow, rather than sudden, change in voltage, it has a serious practical limitation.</p> <p>If a load is attached directly to the R-C network, it will draw off some of the current that was flowing to charge up the capacitor, affecting the timing. In fact, if the resistor is big and appreciable load current is drawn, the capacitor may never charge up fully.</p> <p>One solution, studied here, is to add a transistor to 'buffer' the R-C network, (reduce the current drawn from it.) The load is the lamp. The current through it is an amplified version of the current taken from the R-C network. In other words, a much smaller current is taken from it.</p> <p>Once again, the student should try different combinations of resistor and capacitor.</p>	<p>25 - 35 mins</p>

Page	Notes for the Instructor	Timing
26 Another simple time delay circuit	<p>In the previous circuit, the load current (through the bulb) was only 40mA. With bigger load currents, as here, a more effective buffer is needed - hence the use of a different type of transistor, the MOSFET.</p> <p>The input current to operate a MOSFET is virtually zero. As a result, it is known as a voltage-controlled device. When the capacitor voltage rises to around 2.5V, the MOSFET switches on and the motor spins.</p> <p>It is advisable to include a power diode, connected in reverse-bias as shown. This protects the MOSFET from a high reverse voltage when the motor switches off. At that point, its coil is spinning inside a magnetic field, the conditions needed to generate electricity at high voltage in the reverse direction. The diode begins to conduct and acts as a 'voltage clamp', limiting the reverse voltage across the MOSFET to around 0.7V.</p>	25 - 35 mins
27 Soft-start motor circuit	<p>Electric motors generate electrical noise, affecting other equipment on the same power supply, such as computer and control systems. Equally, for high-power motors, the mechanical strain produced by a sudden start can increase wear-and tear on bearings, gearbox components etc.</p> <p>A 'soft-start circuit' addresses both issues. Relying on the slow rise in voltage across a charging capacitor once again, this circuit is known as a 'source-follower', as the voltage at the MOSFET 'source' terminal mirrors (follows) that across the capacitor, without drawing much current from it. To make this clearer, the student measures the output current through the MOSFET and motor to see that it is gradually increasing.</p>	25 - 35 mins
28 Lamp dimmer - 1	<p>The principal issue here is energy efficiency. Whenever a current flows through electrical resistance, it generates heat and wastes energy. This wasted energy can reduce battery life and increase energy costs. The solution is to reduce the flow of current through resistors.</p> <p>The straightforward way to control the brightness of a lamp is either to control the current through it by adding a series variable resistor or to control the voltage across the lamp using a pot as a voltage divider. Both involve current flowing through resistance. Both are energy inefficient. A more efficient solution is to use a device which behaves like an ideal switch. This dissipates no electrical power.</p> <p>Power = current x voltage:</p> <ul style="list-style-type: none"> <li>• When 'off', the current through an ideal switch (and so the power dissipated in it) is zero.</li> <li>• When 'on', the voltage across the ideal switch (and so the power it dissipates) is zero.</li> </ul> <p>Provided this switching device switches rapidly between 'off' and 'on', the circuit will waste little energy. High-speed switching makes the lamp flash on and off so fast that the human eye does not notice it.</p> <p>There are several ways to turn a device on and off rapidly, such as pulse-width-modulation (PWM). Here, phase control of a triac is used.</p> <p>The triac is related to a thyristor (silicon controlled rectifier) but has the advantage of two-way conduction - appropriate for an AC circuit. It does not conduct for input voltages between +0.7V and -0.7V but switches on rapidly when the voltage rises above (or below) these values.</p>	10 - 15 mins

Page	Notes for the Instructor	Timing
<p>29 Phase control</p>	<p>We have seen that when a DC power supply is used, the voltage across a capacitor in a R-C network rises slowly. With an AC supply, the supply voltage changes continuously and the voltage across the capacitor is always playing 'catch-up'. We say that there is a phase 'lag' between the capacitor voltage and the supply. This can be adjusted using the variable resistor in the R-C network.</p> <p>The capacitor voltage is used to trigger the triac. Putting these two aspects together, the triac triggers when the supply voltage has already risen (or fallen) for some time. Exactly how far into the supply half-cycle depends on the variable resistor setting. A short time later, the triac switches off as soon as the supply voltage returns to zero. This process gives the rapid switching referred to in the previous section.</p> <p>When switching high-power loads, it is vital that the triac switches on and off as rapidly as possible. For this reason, a diac is often included in series with the gate terminal. Its behaviour is straightforward - as soon as the voltage across it rises above the 'breakover' voltage for the device, it flips into conduction and turns on the triac. Overall, this gives a significant reduction in turn-on time and reduces the power dissipated in the triac during switch on / off.</p> <p>The relatively high value of 'breakover' voltage means that this effect cannot be studied experimentally with a low-voltage power supply.</p>	<p>10 - 15 mins</p>
<p>30 Lamp dimmer - 2</p>	<p>This section investigates the switching circuit just discussed, using phase-control though not including the diac.</p> <p>The layout may be slightly misleading as both the pot and the triac use the larger, four terminal carrier. However, as pointed out, the triac is a three terminal device. One of the terminals on the carrier is not used. Although it looks as if the 'spare' end of the pot, the upper right one in the diagram, is connected to the triac, it is not, as that terminal of the triac carrier is not connected to anything.</p> <p>The fixed 10kΩ resistor allows the variable resistor to vary the brightness in a more controlled manner and protects the triac from excessive gate currents that could damage it.</p> <p>To make it clearer what is happening, the student is invited to measure the current through the lamp to see the effect of the phase-control network.</p>	<p>25 - 35 mins</p>



Page	Notes for the Instructor
Introduction to Appendices	<p>The multimeter is one of the most feared of measuring instruments, yet probably the most useful! One problem is that no two models look the same. Another is that it requires knowledge to use it - understanding the symbols, the importance of range and which sockets to use.</p> <p>It is important that students observe the instruction to select the range and connect to the sockets before they switch on. Most multimeters have an internal fuse to protect the meter when measuring current. This can 'blow' if the student makes an incorrect range selection when the meter is turned on. Students need practice in using multimeters and experience of a number of different types, in order to feel confident in their use. The auto-ranging version has both helped and hindered. It reduces the knowledge needed to use it, but masks what is going on.</p> <p>It is important that students can manipulate prefixes like 'kilo' and 'milli' in order to make and understand the measurements. The guidance includes interpretation of the symbols used and identification of appropriate sockets. When other types of meter are used, the instructor may need to explain these to the students.</p>
Appendix 1 Measuring voltage	<p>Measuring voltage is straightforward - just connect the multimeter to the ends of the component being investigated - i.e. in parallel with it.</p> <p>Voltage is simple to measure, but difficult to explain. Electrical current is easy to visualise - a host of little electrons bobbling along a wire. 'Voltage' is why they flow. It is related to the force that pushes them around the circuit, but isn't the force itself. It's related to the energy gained or lost by the electrons as they pass through various components in the circuit, but isn't the energy itself. Hence the phrase "...is a measure of..." That will have to serve for now.</p> <p>Some texts use 'e.m.f' ('electro-motive force') and p.d. ('potential difference') This adds nothing to understanding and increases complexity as the two terms are not interchangeable. For this course, and many others, 'voltage' is fine!</p>
Appendix 2 Measuring current	<p>As pointed out, current is easy to visualise - hordes of electrons bobbling down a wire. As each electron carries an identical amount of negative electrical charge, it can also be described as the rate of flow of electrical charge past a point.</p> <p>However, measuring current is not quite so straight forward. In order to measure current, it must flow through the ammeter. In other words, the ammeter must be connected in series with the component under investigation. To do this, the circuit must be broken to allow the ammeter to be inserted, connected to the two points created by the break.</p>
Appendix 3 Measuring resistance	<p>The most important aspect of measuring resistance is spelled out at the top of the page - the component concerned must be disconnected from the circuit first. (Otherwise, you might be measuring the resistance of other components in the circuit as well.)</p>



Version	Author	Date	Changes
1.0	JV	20/07/2017	Document creation.
2.0	RT	26/04/2018	Contents page amend.

Page 18          6V2 change for 6V8  
Page 8          Change 12ohm to 10ohm  
Page 53          BOM updated

10 08 23 Reformatted to new version