

# locktronics

Simplifying Electricity

## Electrical Installation circuit principles level 3



CP0295

**MATRIX**

[www.matrixtsl.com](http://www.matrixtsl.com)

Copyright © 2016 Matrix Technology Solutions Ltd.

Introduction		3
Worksheet 1 -	AC behaviour of resistors	6
Worksheet 2 -	Combinations of resistors	8
Worksheet 3 -	Capacitors	10
Worksheet 4 -	Capacitor and resistor in series	12
Worksheet 5 -	Capacitor and resistor in parallel	14
Worksheet 6 -	The fuse	17
Worksheet 7 -	The circuit breaker	19
Worksheet 8 -	The RCD	20
Worksheet 9-	Solenoids	21
Worksheet 10-	Relays	22
Appendix		23
	Student Handbook	27
	Instructor Guide	38

## Controlling current:

There are three ways to control electric current - using **resistance**, using **inductive reactance** (hindering current using inductance) and using **capacitive reactance** (hindering current using capacitance) . All three effects are measured in units called ohms (W).

Inductance and capacitance are properties of a particular device and depend on its structure (number of turns of wire, diameter of the coil... for an inductor, area of plates, plate separation... for a capacitor.)

**Impedance** is the sum of all these effects and is also measured in ohms, though it is not found by simply adding together the three effects.

It is calculated from resistance , **R**, inductive reactance, **X<sub>L</sub>**, and capacitive reactance, **X<sub>C</sub>**, using the formula: 
$$Z = \sqrt{R^2 + (X_L - X_C)^2}$$



## The three effects

An electric current is a flow of electrons, tiny negatively-charged particles found in all atoms.

As they flow , they lose energy as heat as they collide with other particles in the material. This effect is called **resistance**.

When electrons flow, they create magnetic fields - that's how electro-magnets work. The magnetic field stores energy, which can be recovered later. It cannot be created instantly. It takes it time to build up and die away. While doing so, it hinders the growth and decline of current. This effect is called **inductive reactance**.

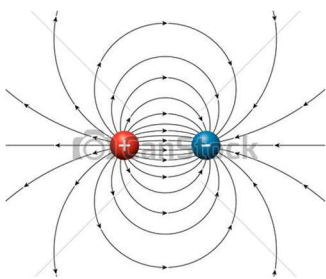

Electrons flow because one end of the circuit is more positively charged than the other. Their negative charge causes them to be attracted to the positively charged end. This situation is called an electric field. It too stores energy. It too cannot be created instantly. Charged particles must be separated to create an electric field. While this happens, electric current is hindered. This effect is called **capacitive reactance**.

## Effect of AC frequency:

**Resistors:** hinder the flow of both AC and DC equally.

**Inductors:** have inductive reactance which hinders AC but has no effect on DC.

**Capacitors :** have capacitive reactance which blocks DC but only hinders AC.

The graph shows:

- the frequency of the AC has no effect on resistance;
- inductive reactance rises as frequency increases;
- capacitive reactance falls as frequency increases.

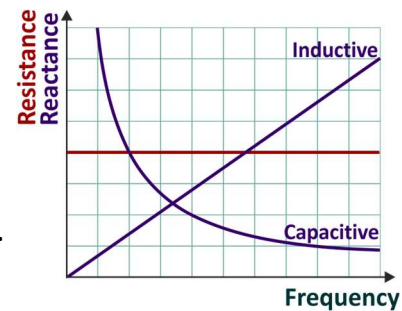

## Ideal components:

**Resistors** - have resistance but zero inductance and zero capacitance.

**Capacitors** - have capacitance but infinite resistance and zero inductance.

**Inductors** - have inductance but zero resistance and zero capacitance.

## Real components:

**Resistors** - wire-wound resistors have appreciable inductance, typically around a few mH.

**Capacitors** - have high, but not infinite resistance. As a result, there is a small leakage current when it is used.

**Inductors** - long lengths of wire wound into a coil, have appreciable resistance which can swamp the reactance at low frequencies, e.g. 50Hz.



## Conflicting demands:

Microelectronics is all about physical size! To exert an effect at low frequencies, they must have a high value of inductance.

*How do you make a physically small inductor?*

You use fine wire, but that has a higher resistance.

*How do you make a high value inductor?*

You use lots of turns of wire, but that increases the resistance too.

The result is that practical inductors made for modern electronic circuits have a high resistance!

In this course, we make no attempt to explore inductive reactance because, at mains frequency (50Hz), huge coils would be required.

## Real components continued...:

The inductor used in the 68mH Matrix carrier has a :

- resistance of 185W;
- inductance of 68mH.



It behaves like a 68mH inductor in series with a 185W resistor.

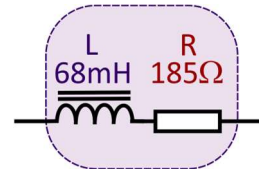

At mains frequency, its inductive reactance,  $X_L$ , is given by the formula:

$$X_L = 2 \pi f L$$

where  $f$  = AC frequency = 50Hz;

and  $L$  = inductance = 68mH.

giving it an inductive reactance of 21.4W.

These effects can be combined together using the formula for impedance:

$$Z = (R^2 + (X_L - X_C)^2)^{\frac{1}{2}}$$

In this case, there is no capacitor and so no capacitive reactance involved, and the formula reduces to:

$$\begin{aligned} Z &= (R^2 + X_L^2)^{\frac{1}{2}} \\ &= ((185)^2 + (21.4)^2)^{\frac{1}{2}} \\ &= 186.2W \end{aligned}$$

This result illustrates the problem of using inductors at relatively low frequencies. Their inductive reactance is drowned by their resistance.

# Worksheet 1

## AC behaviour of resistors

Resistors are basic components in most electronic systems. They control electric current by converting some of its energy into heat. Resistance is measured in units called 'ohms', given the Greek letter omega ' $\Omega$ '. This is often combined with a prefix, such as 'kilo' ('thousand') or 'mega' (million). For example  $1\text{k}\Omega = 1000\Omega$  and  $10\text{M}\Omega = 10$  million ohms.



### Over to you:

- Build the circuit shown below. A possible layout is shown at the bottom of the page.

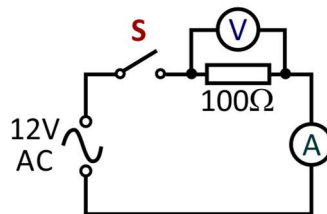

- Connect the 12V AC power supply and switch it on.
- Close switch **S**.
- Use multimeters to measure the current through the resistor and the voltage across it. (Appendix 1 and Appendix 2 will help you with this task if you need it.)
- Record the measurements in the Student Handbook.
- Replace the resistor with a 1kW resistor and repeat the measurements.
- Once again, record them in the Student Handbook and answer the questions.

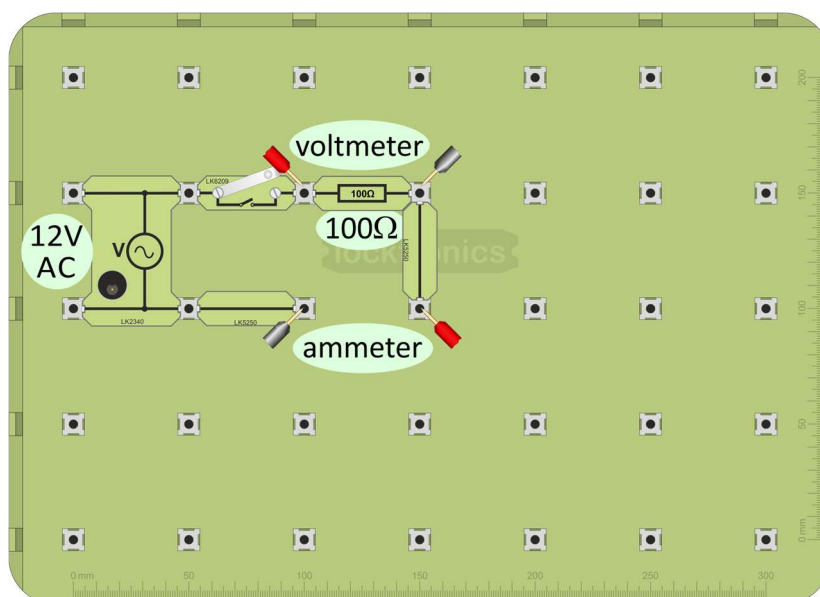

# Worksheet 1

## AC behaviour of resistors

### So what?

In DC circuits, voltage and current in resistors are related in a simple way. The relationship is known as Ohm's law, after the German physicist Georg Ohm.

Their behaviour with AC is no different:

It can be expressed:

- as a graph:

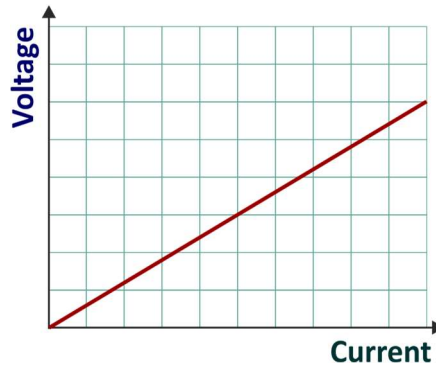

- or in words:

*The voltage across a resistor is directly proportional to the current through it provided its temperature does not change.*

In plain English, this means that:

- if the current doubles, then so does the voltage;
- if the current is reduced to a quarter, then so is the voltage;
- and so on...

**provided** the resistor stays at the same temperature (unlikely to happen!)

The graph gives us information about the **resistance** of the resistor.

A big resistor offers a lot of hindrance to an electric current. It takes a lot of energy from the current as it passes through. Put another way, it takes a large voltage to force the current through it.

A small resistor, on the other hand passes a large current with little hindrance, little loss of energy. It requires only a small voltage.

Using these ideas, it can be seen that trace **A** in the graph shows the effect of a large resistor. It takes a high voltage to drive a relatively small current through it.

Similarly, **B** shows the effect of a small resistor. Even a small voltage creates a large current.

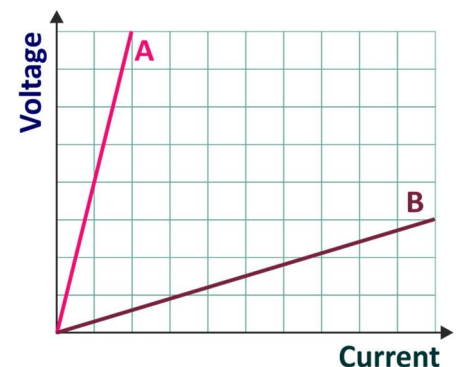

### Be careful!

Sometimes these graphs are plotted with current on the vertical axis and voltage on the horizontal axis. In that case, a slope like **B** would represent a big resistor - a high voltage needed for even a small current.

# Worksheet 2

## Combinations of resistors

There are two types of connection in electronics, series and parallel. In a **series** connection, there are no alternative routes and no junctions - the electric current must pass through each resistor in turn. Components connected in **parallel** offer different routes for the current. Combining resistors in parallel reduces the total resistance, allowing more current to flow.

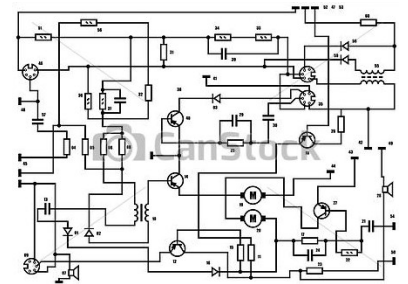

### Over to you:

#### A. Series combination:

- Build the series circuit shown opposite. A possible layout is shown at the bottom of the page.
- Connect the 12V AC power supply and switch it on.
- Close switch **S**.
- Measure the current through the combination of resistors and the voltage across it.
- Record them in the Student Handbook.

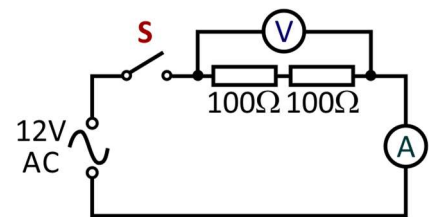

#### B. Parallel combination:

- Build the parallel circuit shown opposite. Again, the layout at the bottom of the page can guide you.
- Connect the 12V AC power supply and switch it on.
- Close switch **S**.
- Measure the current through the combination of resistors and the voltage across it, as indicated in the circuit diagram.
- Record these results in the Student Handbook.

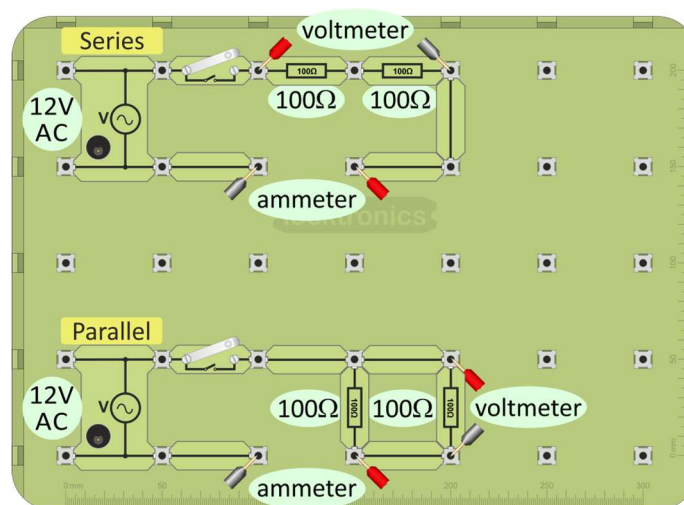
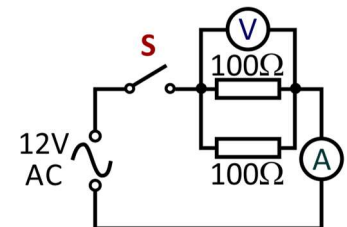



# Worksheet 2

## Combinations of resistors

### So what?

The aim now is to compare the results for the two combinations, one serial and one parallel, with the performance of the  $100\Omega$  resistor by itself.

From the results of the first worksheet, we know that the bigger the resistor, the smaller the current, for the same power supply voltage.

More particularly, when the resistor is ten times bigger, the current is ten times smaller.

The theoretical results are:

for a series combination, total resistance =  $R_1 + R_2$ ;

for a parallel combination, total resistance =  $\frac{R_1 \times R_2}{R_1 + R_2}$

The treatment in the Student Handbook uses the measurements to calculate the total resistance of the two combinations, i.e. to find the value of the single resistor that would have the same effect as each combination.

In the Student Handbook:

- use the measurements to calculate the total resistance for each combination;
- complete the table to show your results.

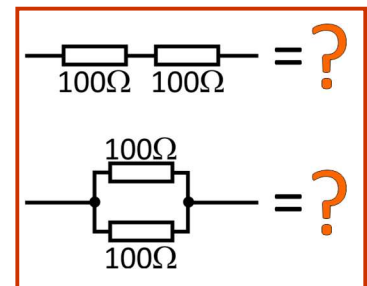

# Worksheet 3

## Capacitors

In an inductor, an electric current sets up a **magnetic** field inside it which opposes changes to the **current** through the inductor.  
In a capacitor, the current sets up an **electric** field across the plates which opposes changes to the **voltage** applied to the capacitor.

- Before the voltage can increase, electrons must flow onto the plates of the capacitor, increasing the electric field. This stores energy in the electric field.
- When the voltage tries to decrease, electrons flow off the plates, reducing the electric field. These electrons try to maintain the voltage across the capacitor.

Capacitors behave rather like buckets in a water circuit. They must fill up before water flows anywhere else in the circuit. When the flow of water starts to fall, excess water flows from the bucket, trying to maintain the flow.



### Over to you:

A **capacitor** consists of two metal plates, separated by a thin film of an insulator, sometimes called a dielectric. Its **capacitance**, measured in a unit called the farad (F), depends on factors like the area of the plates, their separation and the material used as the dielectric.

The circuit diagram shows a capacitor connected to a 12V 50Hz power supply. The capacitor has a capacitance of  $33\mu\text{F}$ , (33 microfarads) -33 millionths of a farad. Notice the circuit symbol for the capacitor.

- Build the circuit shown in the circuit diagram.

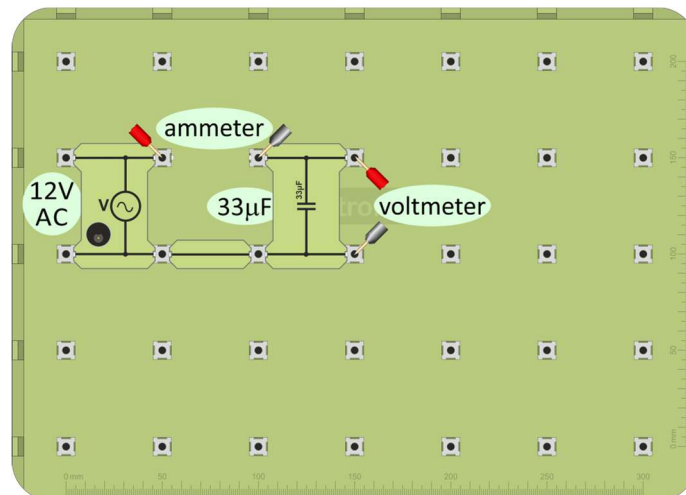
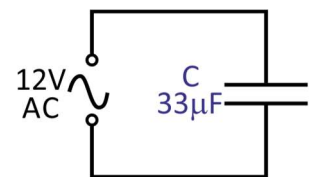

- Measure the current through the capacitor and the voltage across it.
- Record these in the Student Handbook. (There is space for two sets of measurements, to allow you to improve the accuracy of your results.)
- Now replace the  $33\mu\text{F}$  capacitor with the  $2.2\mu\text{F}$  capacitor.
- Repeat the procedure and record the measurements in the Student Handbook.
- Complete the calculations in the Student Handbook.

# Worksheet 3

## Capacitors



### So what?

- With resistors, when you double the current through the resistor, you double the voltage dropped across it, and so on...
- Capacitors oppose a *changing* voltage.  
The faster the *rate of change* of *voltage*, the greater the current that must flow to charge or discharge the capacitor.  
The higher the frequency of the AC, the faster the *voltage* changes, and so the greater the current that flow in the circuit.  
In other words, the *current* depends on the frequency of the AC supply.
- We describe this behaviour in terms of the **capacitive reactance,  $X_C$** , defined, in the same way as resistance, as  $X_C = V / I$ . As stated before, the units of reactance are ohms.
- The capacitive reactance measures the opposition of the capacitor to changing current.  
The higher the frequency, **f**, the greater the change in voltage, and the greater the current flow.  
The formula for capacitive reactance is:  
$$X_C = 1 / (2 \pi f C)$$
- Capacitors are very much a mirror image of inductors.  
As the frequency of the AC supply increases, an inductor offers **more** opposition, (i.e. inductive reactance **increases**, and the current **decreases**) whereas a capacitor offers **less** opposition, (i.e. capacitive reactance **decreases**, and the current **increases**).
- In the Student Handbook, use your measurements to calculate  $X_C$  for each capacitor:
- using your measurements in the formula:  
$$X_C = V / I$$
  
where **V** = voltage across the capacitor  
and **I** = current flowing through it.
- using the formula:  
$$X_C = 1 / (2 \pi f C)$$
  
where **f** = AC frequency (=50Hz)  
and **C** = capacitance.  
and compare the results
- Complete the table given in the Student Handbook with your results.

# Worksheet 4

## Capacitor and resistor in series

A capacitor and a resistor, connected in series, act as a voltage divider, sharing the AC voltage in a way that depends on the frequency of the AC supply. However, the reactance of the capacitor *decreases* as the frequency increases. This type of circuit is known as a series C-R circuit. As it is in series, the same current flows in all parts.

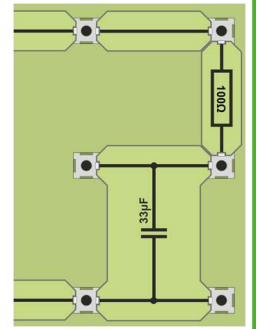

### Over to you:

- Connect a  $100\Omega$  resistor, and a  $33\mu\text{F}$  capacitor in series with the 50Hz 12V AC supply, as shown in the circuit diagram and in the layout below.

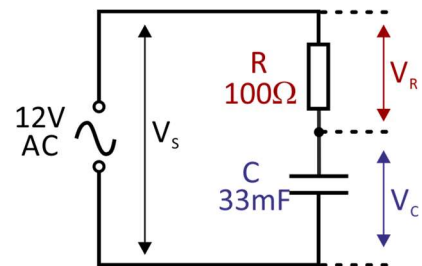
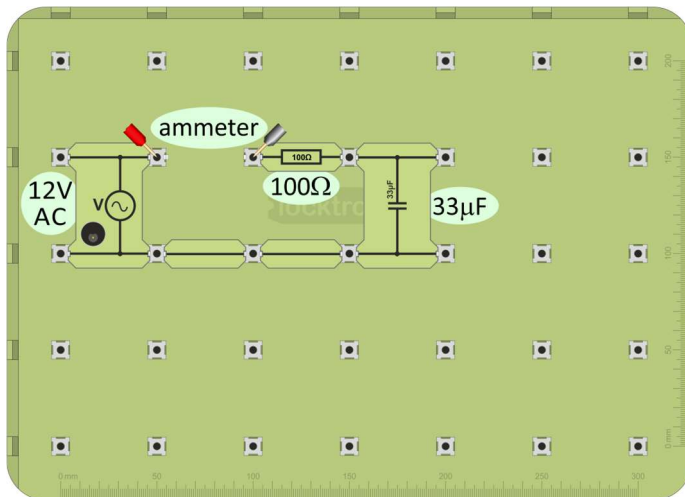

- Measure the current leaving the AC power supply.
- Measure:
  - the AC supply voltage,  $V_s$ ;
  - the voltage  $V_C$ , across the capacitor;
  - the voltage  $V_R$ , across the resistor.
- Record these voltages in the Student Handbook and complete the calculations.

# Worksheet 4

## Capacitor and Resistor in Series

### So what?

In a resistor, the current is *in phase* with the applied voltage. In other words, they rise and fall in step.

When voltage is a maximum, so is current and so on... .

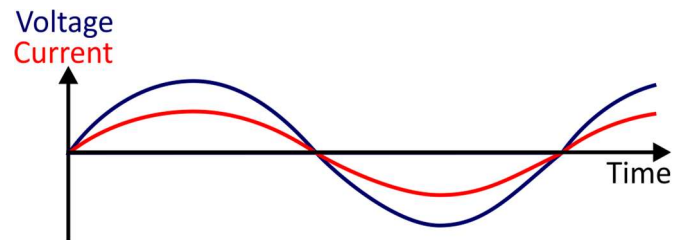

In a capacitor, they are not in phase.

The current *leads* the applied voltage.

Because of this, it is complicated to work out exactly what is happening in the circuit.

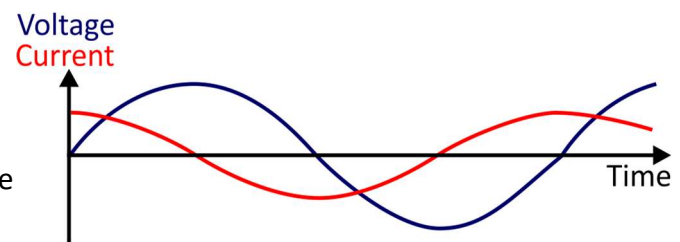

The solution is to work out the impedance of the combination, i.e. the 'sum' of the resistance and the capacitive reactance. This takes into account the phase differences between the various voltages and currents in the circuit.

- The two effects limiting the current are - the resistance ( $100\Omega$ ) of the resistor, and the reactance of the capacitor.

For the  $33\mu\text{F}$  capacitor, at a frequency of  $50\text{Hz}$ , capacitive reactance can be calculated using:

$$\begin{aligned} X_c &= 1 / (2 \pi f C) \\ &= 1 / (2 \pi (50) \times (33 \times 10^{-6})) \\ &= 96.5\Omega \end{aligned}$$

- The voltage across the resistor is in phase with the current through it. The voltage across the capacitor lags behind the current. The impedance formula takes this phase shift into account:

$$Z = (R^2 + (X_L - X_C)^2)^{1/2}$$

In this case, there is no inductive reactance, and so:

$$\begin{aligned} Z &= (R^2 + X_C^2)^{1/2} \\ &= ((100)^2 + (96.5)^2)^{1/2} \\ &= 138.9\Omega \end{aligned}$$

- In the Student Handbook, use this value of impedance to calculate theoretical values for  $V_R$  and  $V_L$  for both capacitors.

As the frequency increases, the share of the supply voltage changes. The *higher frequency reduces* the reactance of the capacitor. As a result, the capacitor takes a much lower share of the supply voltage.

# Worksheet 5

## Capacitor and resistor in parallel

When a capacitor and a resistor are connected in parallel, they act

as a current divider, sharing the AC current.

The way the current is divided between the two routes depends on the frequency of the AC supply. When the supply frequency increases, the reactance of the capacitor *decreases*, making it an *easier* route for the current to flow through.



### Over to you:

- Connect a  $500\Omega$  resistor and a  $33\mu\text{F}$  capacitor in parallel with the 50Hz 12V AC supply, as shown in the diagram opposite and the layout below.
- Use enough connecting links so that the current can be measured at points **A** and **B**.
- Measure:
  - the current,  $I_A$ , through the capacitor (i.e. at point **A**);
  - the current  $I_B$ , through the resistor (i.e. at point **B**).
- Measure the supply voltage,  $V_s$ .
- Record these measurements in the Student Handbook and complete the calculations.

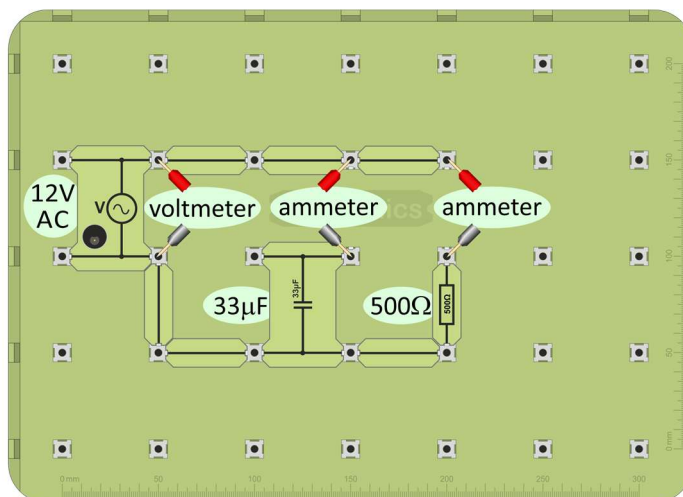
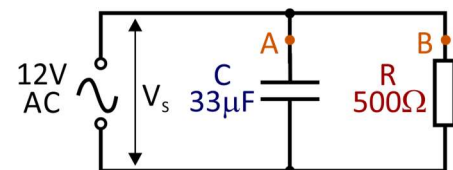

# Worksheet 5

## Capacitor and Resistor in Parallel



### So what?

- We are going to calculate the quantities you measured, from theory so that you can compare them with your results.

Use your value of  $V_S$  to complete the calculations below in the template provided in the Student Handbook..

### At a frequency of 50Hz

- Resistance of resistor  $R = 500\Omega$ ,  
and so the current through it, (at point B,)  $I_B = V_S / R = \dots\dots\dots / 500 = \dots\dots\dots$  A

- Reactance  $X_C$  of capacitor C is given by:

$$\begin{aligned} X_C &= 1 / 2 \pi f C \\ &= 2 \pi (50) \times (33 \times 10^{-6}) \\ &= 96.5\Omega \end{aligned}$$

and so the current through it, (at point A,)  $I_A = V_S / X_C = \dots\dots\dots / 96.5 = \dots\dots\dots$  A

- The currents through the capacitor and the resistor are not in phase:
- the current,  $I_B$ , through the resistor is in phase with  $V_S$ ;
- the current,  $I_A$ , through the inductor lags behind  $V_S$  by  $90^\circ$ .

As the frequency of the AC changes, the share of the *current* changes. When the frequency increases, the reactance of the capacitor decreases and so the path for current through it becomes easier. The current through the capacitor increases.

The resistance of the resistor is unaffected by frequency changes.

# Electrical Safety



# Worksheet 6

## The fuse

Electricity is **dangerous!**

Our bodies can sense electric currents as small as 1mA. A current of 10 mA DC can cause muscle contractions - the victim cannot release the electrified object.

The voltage required depends on a number of factors, including the electrical resistance of the human body, which, in turn, depends on:

- the presence of sweat on the skin;
- the hydration level of the body - 45 to 70% of the weight of the body is water;
- the body fat content;
- where on the body the electrical contact occurs.

The resistance of the human body is typically between 1k $\Omega$  and 100k $\Omega$ . The low voltage used in your experiments is safe, but the much higher voltages in mains electricity supplies can kill.



### Over to you:

One effect of an electric current is to heat the wires and devices it flows through. If there is a problem, wires can get so hot that they cause a fire.

**We need a safety device to prevent a fire when an electrical fault occurs!**

One answer is to use a **fuse**.

The next investigation illustrates this approach.

- Clamp one or two fibres of steel wool between the pillars of the sampler to form a simple fuse.
- Build the circuit shown in the diagram, using a 12V **AC** power supply and a 12V 0.1A bulb.
- Leave one end of the black lead loose. Make sure that it does not touch any part of the circuit!
- Close the switch - the bulb should light.

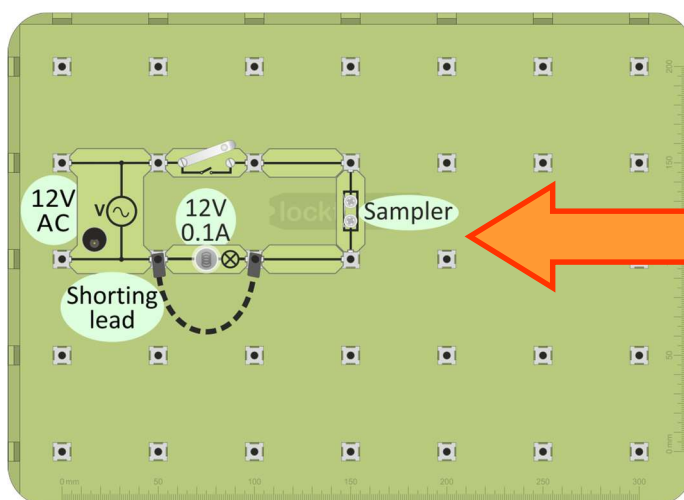
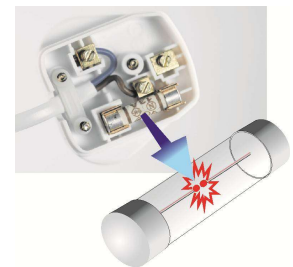

Strands of steel wool

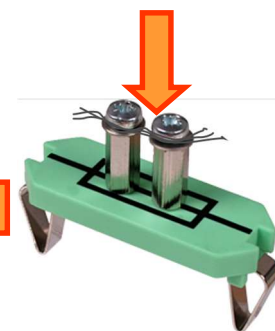

- Now create a fault in the circuit. Touch the loose end of the black lead onto the right hand side of the bulb, for a moment. You just short-circuited the bulb.
- What happens?
- Record your observations in the Student Handbook.

# Worksheet 6

## The fuse

### So what?

Electricity is **dangerous!**

'Short-circuits' are a potentially harmful effect of electrical heating. Worn or damaged insulation lets wires touch, allowing very large currents to flow. These can generate a lot of heat, causing fires.

One precaution is an application of electrical heating, the fuse - a short length of wire made from a metal with a low melting point. It acts as the weakest point in the circuit. A large current flowing through it heats it so much that it melts. This breaks the circuit, stopping the current before it causes damage.

The picture shows the connections in a UK 13A plug. The 'cartridge fuse' protects the wiring installation and appliance. It is important that the correct fuse rating is used for the appliance. These cartridge fuses typically come in values of 3A, 5A and 13A.



### Calculating fuse values:

We need to know:

- the power rating, **P**, of the appliance;
- the voltage, **V**, it is designed to work on.

From these, we first use the formula  $P = I \times V$  (or  $I = P / V$ ) to work out the **normal** current, **I**, flowing through the appliance. This current is fine - no overheating will occur.

Then we choose a fuse value just greater than this so that the fuse will 'blow' cutting off all current when a problem occurs.

For example:

- A modern TV - power rating (**P**) 200W on a 240V power supply (**V**).
- normal current (**I**) =  $200 / 240 = 0.8A$ .

**The best cartridge fuse rating for this is 3A.**

Calculate the normal current and best cartridge fuse value for the appliances listed in the Student Handbook.

# Worksheet 7

## The circuit breaker

Electricity is **dangerous!**



**Fuses** protect the appliance and the wiring connecting it, but **NOT** the user!

A fuse may happily pass a 10A current without 'blowing'. The human body would **not** be happy with a current of 10A!

**Circuit breakers** (MCBs), similarly, offer protection for the appliance but not the user, by switching off the circuit when it senses excessive current. Like the fuse, it protects the appliance and wiring. Whereas a 'blown' fuse must be re-wired or replaced, the MCB is reset, by pressing a button or operating a switch.



### Over to you:

The modern consumer unit contains both MCBs (miniature circuit breakers) and RCDs (residual current devices). However, these have different functions. RCDs are explored in the next worksheet.

- Build the layout shown below.

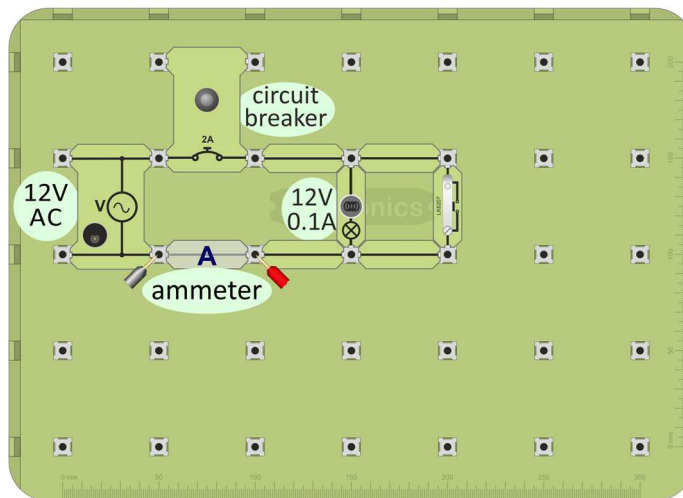

- Connect the 12V AC power supply and switch on.
- Press the circuit breaker 'Reset' button if necessary. The lamp should turn on.
- Press the switch to introduce a fault - it short-circuits the bulb. The circuit breaker should trip as its rated current is exceeded.
- Restore the supply by pressing the 'Reset' button again.

### Challenge:

- Switch off the power supply and remove the connecting link at **A**.
- Replace it with an ammeter, set to read up to 10A AC.

Now modify the circuit by adding a 250Ω variable resistor so that you can measure the current that causes the circuit breaker to 'trip'. Record your results in the Student Handbook.

# Worksheet 8

## The RCD

Electricity is **dangerous!** Fuses and circuit breakers protect the appliance and the wiring connecting it, but **NOT** the user!

The **RCD** (residual current device) compares the current it supplies **to** the appliance with the current, which flows back **from** it. An imbalance might indicate a fault, such as an electric current flowing to earth through the user.

The RCD then 'trips', shutting off the electricity supply to the appliance and the user.



### Over to you:

A faulty electrical appliance might give the user an electric shock, with a current,  $I_{\text{fault}}$ , flowing to earth through the user. The **RCD** compares the current ( $I_{\text{out}}$ ) flowing **to** with that ( $I_{\text{back}}$ ) returning **from** an appliance. When the difference ( $I_{\text{out}} - I_{\text{back}}$ ) reaches a set value (typically 30mA), the RCD 'trips', shutting off the electricity supply.

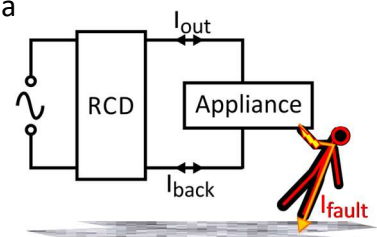

- Build the layout shown below, connect the 12V AC power supply and switch on.

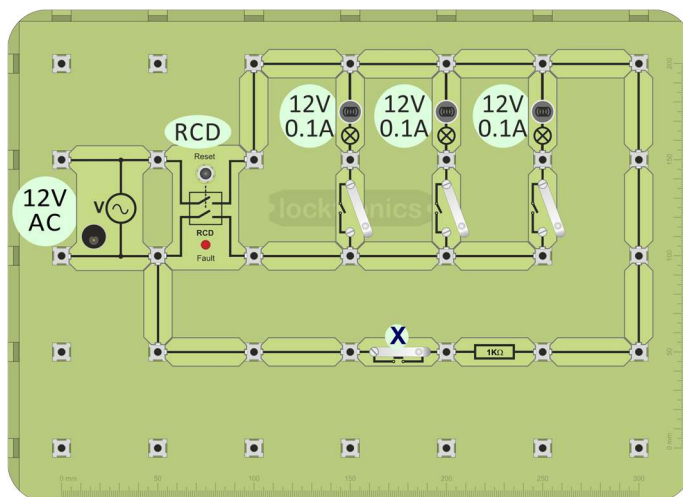

- Press the 'Reset' button on the RCD if necessary. The three lamps can be controlled separately by the on/off switches.
- Simulate a fault by pressing switch **X**. This diverts some current around the RCD, producing an imbalance in the currents leaving and returning to it.
- The RCD 'trips', switching off the supply and lighting the 'Fault' LED on the RCD.
- Restore the supply by pressing the 'Reset' button again.
- Replace the 1kΩ resistor with a 10kΩ variable resistor.

### Challenge:

Modify your circuit by adding a 10kΩ variable resistor so that you can measure the fault current which causes the RCD to trip. Record your result in the Student Handbook.

# Worksheet 9

## Solenoids

One effect of an electric current is that it heats up the conductors that it flows through. Another is that it produces a magnetic field around that conductor.

This is put to use in electromagnets, like the one shown in the picture which is used to move steel ingots in a steel works.

The magnetic effect is stronger if the conductor is made into a coil. It is even stronger if the coil has a core of a material such as ferrite.

The first part of the worksheet looks at this magnetic effect in a solenoid, a cylindrical coil of wire, with and without a core.

The second part investigates a commercial solenoid, used to turn electrical energy into linear motion.



### Over to you:

- Build the layout shown opposite. The purpose of the lamp is to show when there is a current flowing. The purpose of the compass needle is to detect any magnetic field.
- Connect a **DC** power supply set to deliver **6V**.
- Press the switch. The lamp should turn on. Notice the effect on the compass needle.
- Remove the ferrite core and repeat the procedure. Is there any difference?
- Replace the ferrite core.
- Turn the power supply carrier upside down to make the current flow in the opposite direction. What is the effect on the compass needle?
- Build the second layout. This time, the solenoid is enclosed and has at its core a moveable plunger, or actuator. This is magnetised by the magnetic field of the solenoid and then interacts with that magnetic field to produce motion.
- Press the switch. Notice the effect on the core of the solenoid.
- Record all your observations in the Student Handbook.

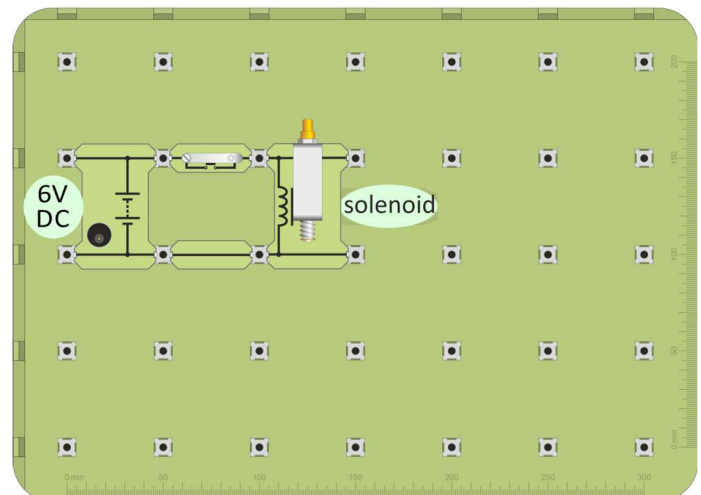
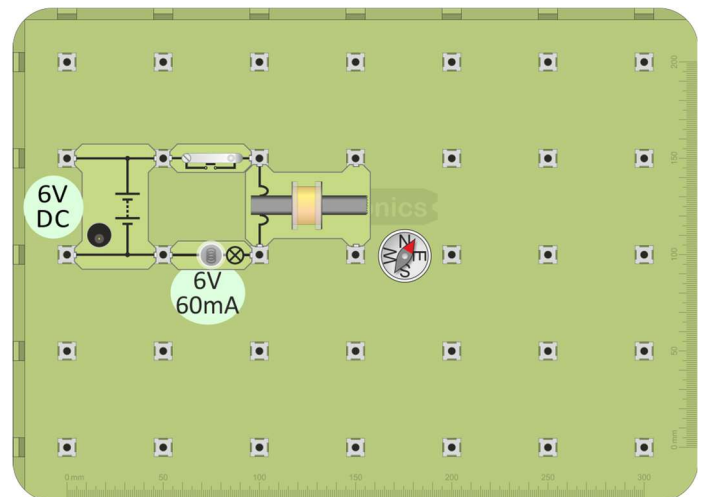

# Worksheet 10

## Relays

The relay is another application of electromagnetism - a remotely controlled switch. Operated from a low voltage, low current control circuit, it can be used to switch large currents and high voltages, or can be used to operate devices in a hazardous environment from a safe distance.

When a current flows through the coil, a magnetic field is created which magnetises the core. This attracts a pivoted armature to it. As it moves towards the core, it rocks around the pivot and closes a pair of contacts in the process. (Other forms of relay can open 'normally-closed' contacts or act as a changeover switch.)

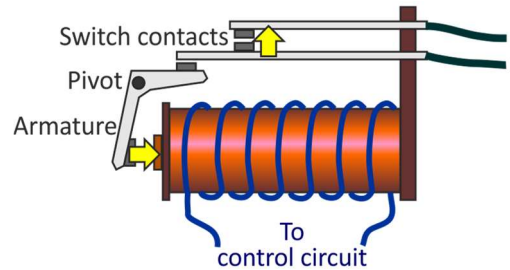

### Over to you:

The next system illustrates how a solenoid actuator can be operated from a remote switch, using a relay. It also demonstrates how a small current in the control circuit can switch a much larger current. The circuit includes two diodes, connected to prevent any damage to other components when the relay coil or solenoid de-energise.

- Build the circuit shown above using a layout like that below.

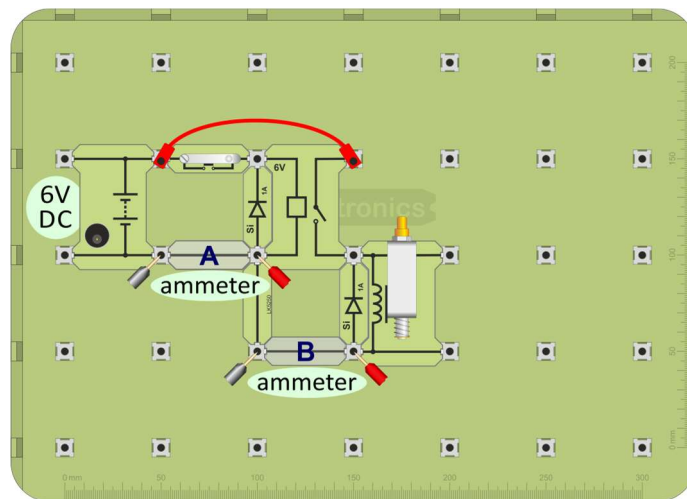
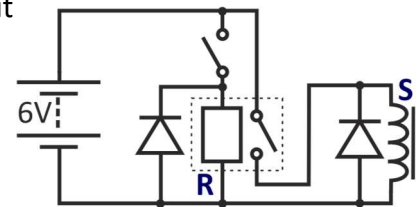

- Connect a **DC** power supply **set to deliver 6V**.
- Remove the connecting link at **A** and measure the current at this point. This is the current that flows through the relay, i.e. the control circuit current.
- Replace link **A** and in the same way, measure the current flowing at point **B** - the current demanded by the load, the solenoid in this case.
- You should find that a circuit like this can control a large load current using a much smaller current in the control circuit.
- Record all results in the Student Handbook.

# **Electrical Science and Technology**

## **Appendix**

-

# **Electrical measurements with a multimeter**



The picture shows one form of multimeter. It has a wide range of uses -which varies from model to model - but usually includes measuring AC and DC voltage and current

When using a multimeter, before you switch it on:

- take care to plug the probes into the correct sockets;
- select the correct range.

(‘Auto-ranging’ versions select the best range automatically.)

## Voltage:

- is a measure of the force pushing the electrons around the circuit;
- measures energy lost or gained as an electron moves through part of a circuit
- is measured with a voltmeter connected in parallel with the component.

The circuit symbol for a voltmeter is shown in the diagram.



## Using a multimeter to measure voltage:

Multimeters can measure both AC and DC.

The following symbols distinguish between them:

- Plug one wire into the black ‘COM’ socket.
- Plug another into the red ‘V’ socket.
- Select the 20V DC range by turning the dial to the ‘20’ mark next to the ‘V ’ symbol.

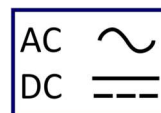

(It is good practice to set the meter on a range that is much higher than the reading you are expecting. Then refine it by choosing a lower range to suit the voltage you find.)

- Plug the wires into the sockets at the ends of the component under investigation.
- Switch on the multimeter when you are ready to take a reading.
- A ‘-’ sign in front of the reading means that the meter wires are connected the wrong way round. Swap them over to get rid of it!







When using a multimeter to measure current, plug the probes into the 'A' and 'COM' sockets, or equivalents.

Then select the correct range, either from the 'A~' section, for AC current or the 'A' section, for DC current.

Finally, switch on. 

### Current:

- measures the number of electrons passing any point in the circuit each second;
- measures the rate of flow of electrical charge in the circuit;
- is measured with an ammeter connected in series with the component.

The circuit symbol for a ammeter is shown in the diagram.



### Using a multimeter to measure current:

- Plug one wire into the black 'COM' socket.
- Plug another into the red 'mA' socket.
- Select the 200mA DC range by turning the dial to the '200m' mark next to the 'A ' symbol.  
(Again, it is best to set the meter on a higher range to begin with. Then choose a lower range to suit the current you find.)
- Break the circuit where you want to measure the current, by removing a link, and then plug the two multimeter leads in its place.
- Switch on the multimeter when you are ready to take a reading.
- A possible problem:  
The ammeter range is protected by a fuse located inside the body of the multimeter. This may have 'blown', in which case the ammeter will not work. Report any problems to your instructor so that it can be checked.



**When using a multimeter to measure resistance, the component must be removed from the circuit first!**

Once again, before you switch on:

- take care to plug the probes into the correct sockets, the ' $\Omega$ ' and '**COM**' sockets;
- select the correct range.

### Resistance:

- is a hindrance to the flow of electrons around the circuit;
- removes energy from each electron as it moves through the resistor;
- converts this energy into heat;
- is measured in units called 'ohms' (symbol - ' $\Omega$ ') or kilohms ( $k\Omega$ ), using an ohmmeter. (1 kilohm = 1 000 ohms.)

### Using a multimeter to measure resistance:

- Plug one wire into the black '**COM**' socket.
- Plug another into the red ' $\Omega$ ' socket.
- Turn the dial to select a resistance range, such as  $200k\Omega$ .  
(Once again, it is good practice to set the meter on a range higher than the reading you are expecting and then refine it to a lower range.)
- Make sure that the component under investigation is not connected to any other.
- Plug the wires into the sockets at the ends of the component.
- Switch on the multimeter when you are ready to take a reading.



**Electrical  
Science  
and  
Technology  
Level 3**

**Student  
Handbook**

-

**For your records**

## Introduction

### Controlling current:

Three ways to control electric current, all measured in units called ohms ( $\Omega$ ):

- using resistance:
- using inductive reactance (hindering current using inductance);
- using capacitive reactance (hindering current using capacitance).

Inductance and capacitance are properties of a particular device and depend on its structure.

Impedance is the sum of all these effects and is also measured in ohms, though it is not found by adding together the three effects but using the formula:  $Z = \sqrt{R^2 + (X_L - X_C)^2}$

An electric current is a flow of electrons, tiny negatively-charged particles found in all atoms. As they flow, they lose energy as heat as they collide with other particles in the material. This effect is called resistance.

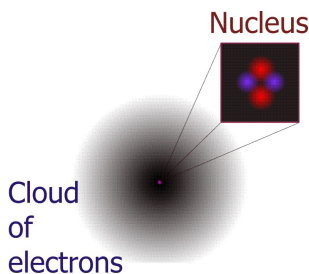

When electrons flow, they create magnetic fields. The magnetic field stores energy, which can be recovered later. It cannot be created instantly. It takes it time to build up and die away. While doing so, it hinders the growth and decline of current. This effect is called inductive reactance.

Electrons flow because one end of the circuit is more positively charged than the other. Their negative charge causes them to be attracted to the positively charged end. This situation is called an electric field. It too stores energy. It too cannot be created instantly. Charged particles must be separated to create an electric field. While this happens, electric current is hindered. This effect is called capacitive reactance.

### Effect of AC frequency:

**Resistors:** hinder the flow of both AC and DC equally.

**Inductors:** have inductive reactance which hinders AC but has no effect on DC.

**Capacitors:** have capacitive reactance which blocks DC but only hinders AC.

## Introduction continued...

The graph shows:

- the frequency of the AC has no effect on resistance;
- inductive reactance rises as frequency increases;
- capacitive reactance falls as frequency increases.

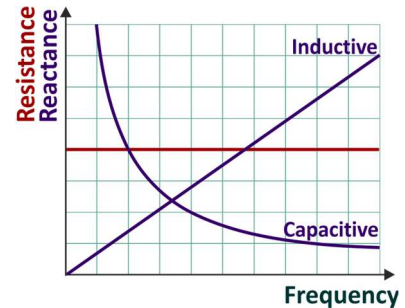

## Ideal components:

**Resistors** - have resistance but zero inductance and zero capacitance.

**Capacitors** - have capacitance but infinite resistance and zero inductance.

**Inductors** - have inductance but zero resistance and zero capacitance.

## Real components:

**Resistors** - wire-wound resistors have appreciable inductance, typically around a few  $\mu\text{H}$ .

**Capacitors** - have high, but not infinite resistance, resulting in a small leakage current when used.

**Inductors** - long lengths of wire wound into a coil, have appreciable resistance which can swamp reactance at low frequencies, e.g. 50Hz.

## Worksheet 1 - AC behaviour of resistors:

Resistors control electric current by converting some of its energy into heat.

Resistance is measured in units called 'ohms', ( $\Omega$ ), often combined with a prefix e.g.  $1\text{k}\Omega = 1000\Omega$ ,  $10\text{M}\Omega = 10$  million ohms.

Their behaviour with AC is no different from their behaviour with DC:

*The voltage across a resistor is directly proportional to the current flowing through it provided its temperature does not change.*

In plain English, this means that:

- if the current doubles, then so does the voltage;
- if the current is reduced to a quarter, then so is the voltage;
- and so on... **provided** the resistor stays at the same temperature (unlikely to happen!)

## Worksheet 1 - AC behaviour of resistors continued...

A big resistor offers a lot of hindrance to an electric current. It takes a lot of energy from the current as it passes through. Put another way, it takes a large voltage to force the current through it.

A small resistor, on the other hand passes a large current with little hindrance, little loss of energy. It requires only a small voltage.

Using these ideas, it can be seen that trace **A** in the graph shows the effect of a large resistor. It takes a high voltage to drive a relatively small current through it.

Similarly, **B** shows the effect of a small resistor. Even a small voltage creates a large current.

### Be careful!

When this graph is plotted with current on the vertical axis and voltage on the horizontal axis, a slope like **B** would represent a big resistor - a high voltage needed for even a small current.

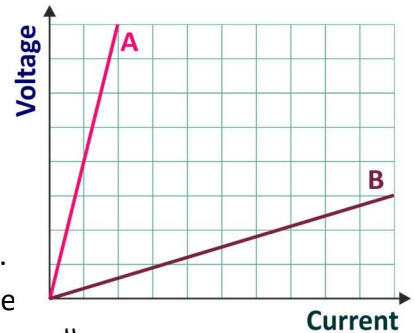

### Your results:

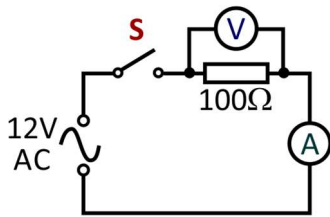

Resistor	Current in mA	Voltage in V
100Ω		
1kΩ		

Complete the sentence:

The bigger the resistor, the ..... the current, for a given voltage.

### Measured values of resistance:

Use the formula: Resistance = voltage / current with your measurements to calculate the values of the resistors:

'100Ω' resistor - measured value = ..... = .....Ω

.....

'1kΩ' resistor - measured value = ..... = .....Ω

.....

With the power supply used in this investigation, estimate the current that would flow through a 50Ω resistor:

Estimated current = .....

## Worksheet 2 - Combinations of resistors:

**Series** connection - no alternative routes - no junctions - the electric current must pass through each resistor in turn. Combining resistors in series increases total resistance.

**Parallel** connection - offers different routes for the current. Combining resistors in parallel reduces the total resistance.

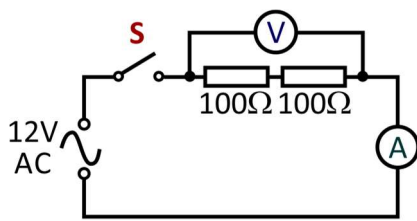

Series

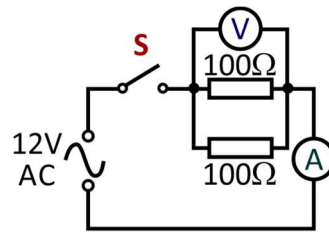

Parallel

### Your results:

Combination	Current in mA through combination	Voltage in V across combination
Two 100Ω in series		
Two 100Ω in parallel		

### Total resistance:

For a series combination, total resistance =  $R_1 + R_2$ ;

For a parallel combination, total resistance =  $\frac{R_1 \times R_2}{R_1 + R_2}$

### Measured resistance:

Using your results in the formula  $R = V / I$ :

- two 100Ω resistors in series have a total resistance of ..... Ω;
- two 100Ω resistors in parallel have a total resistance of ..... Ω.

How do you account for any differences between stated and measured values?

.....

.....

.....

.....

## Worksheet 3 - Capacitors:

Capacitance, **C**, is measured in **farads (F)**, though, in practice, this unit is too large. Most capacitors have values given in microfarads ( $\mu\text{F}$ ), nanofarads (nF) or picofarads (pF).

- Capacitors oppose a *changing* voltage.  
The faster the voltage changes, the greater the current needed to charge or discharge the capacitor. The higher the AC frequency, the faster the voltage changes, and so the greater the current.  
In other words, current depends on the frequency of the AC supply.
- We describe this behaviour in terms of the **capacitive reactance,  $X_C$** , defined, in the same way as resistance, as  $X_C = V / I$ . As stated earlier, the units of reactance are ohms.
- Capacitive reactance measures the capacitor's opposition to changing current.  
The formula for capacitive reactance is:  $X_C = 1 / (2 \pi f C)$
- Capacitors are a mirror image of inductors.  
As the AC frequency increases, an inductor offers **more** opposition, - inductive reactance **increases**, whereas a capacitor offers **less** opposition, - capacitive reactance **decreases**.

Capacitors behave rather like buckets in a water circuit. They must fill up before water flows anywhere else in the circuit. When the flow of water starts to fall, excess water flows from the bucket, trying to maintain the flow.

### Your results:

Capacitor	Frequency	Current I	Voltage V
33 $\mu\text{F}$	50Hz		
2.2 $\mu\text{F}$	50Hz		

The stated value takes no account of meter and component tolerances and factors like the finite resistance of the insulating layer between the capacitor plates.

### Your calculations:

Capacitor	Frequency	Capacitive reactance $X_C = V / I$	Capacitive reactance $X_C = 2 \pi f L$
33 $\mu\text{F}$	50Hz		
2.2 $\mu\text{F}$	50Hz		

Complete the following statement:

When the AC frequency is doubled, the capacitive reactance is .....

When the capacitance is increased, the current .....



## Worksheet 4 - Capacitor and resistor in series:

At a frequency  $f$ , the reactance of a capacitor is:  $X_C = 1 / (2 \pi f C)$

and the impedance of a C-R circuit is:  $Z = (R^2 + X_C^2)^{1/2}$

The (rms) current is given by:  $I = V_S / Z$

The resulting voltage across the resistor is:  $V_R = I \times R$

and the voltage across the capacitor is:  $V_C = I \times X_C$ .

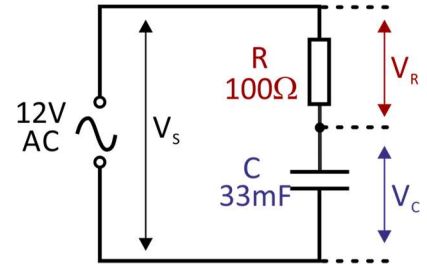

In a resistor, the current is *in phase* with applied voltage. In other words, they rise and fall in step. When voltage is a maximum, so is current ...

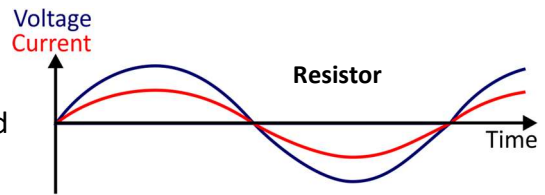

In a capacitor, they are not in phase. Current *leads* applied voltage. As a result, it is complicated to work out exactly what is happening.

The **impedance** of the combination takes into account these phase differences. To calculate this, first we need the reactance of the capacitor:

$$\begin{aligned} X_C &= 1 / (2 \pi f C) \\ &= 1 / (2 \pi (50) \times (33 \times 10^{-6})) \\ &= 96.5 \Omega \end{aligned}$$

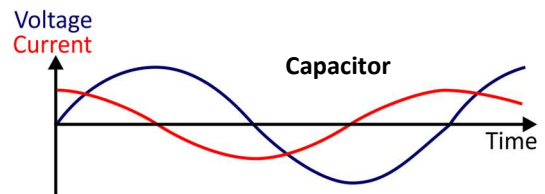

The voltage across the resistor is in phase with the current through it.

The voltage across the capacitor lags behind the current.

As there is no inductive reactance, the impedance formula reduces to:

$$\begin{aligned} Z &= (R^2 + X_C^2)^{1/2} \\ &= ((100)^2 + (96.5)^2)^{1/2} \\ &= 138.9 \Omega \end{aligned}$$

Using the formula:  $I = V_S / Z$ , this gives the current:  $I = \dots\dots\dots$  mA.

and using  $V_R = I \times R$ , it gives the voltage across the resistor:  $V_R = \dots\dots\dots$  V,

and using  $V_C = I \times X_C$ , the voltage across the capacitor:  $V_C = \dots\dots\dots$  V.

Check these results against your measured values.

### Your results:

Measurement	
Power supply current, I, in mA	
Supply voltage $V_S$	
Voltage $V_R$ across 100Ω resistor	
Voltage $V_C$ across 33μF capacitor	

As the frequency increases, the way the supply voltage is shared changes. At a *higher* frequency, the reactance of the capacitor *decreases* and so it takes a much lower share of the supply voltage.

## Worksheet 5 - Capacitor and resistor in parallel:

When a capacitor and a resistor are connected in parallel, they act as a current divider, sharing the AC current.

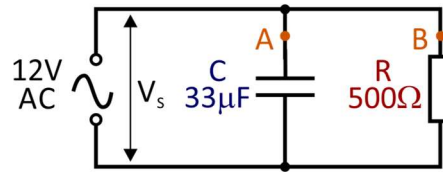

The way the current divides between them depends on the frequency of the AC supply. When the frequency increases, the reactance of the capacitor *decreases*, making it an *easier* route for the current to flow through.

The currents through the capacitor and the resistor are not in phase:

- the current at **B**, through the resistor, is in phase with  $V_s$ ;
- the current at **A**, through the capacitor, leads  $V_s$  by  $90^\circ$ .

### At a frequency of 50Hz

- Resistance of resistor  $R = 500\Omega$ ,  
and so the current through it, (at point **B**),  $I_B = V_s / R = \dots\dots\dots / 500 = \dots\dots\dots$  A

- Reactance  $X_C$  of capacitor **C** is given by:

$$\begin{aligned} X_C &= 1 / 2 \pi f C \\ &= 2 \pi (50) \times (33 \times 10^{-6}) \\ &= 96.5\Omega \end{aligned}$$

and so the current through it, (at point **A**),  $I_A = V_s / X_C = \dots\dots\dots / 96.5 = \dots\dots\dots$  A

Check these results against your measured values.

### Your results:

Measurement	
Current $I_A$ at point A in mA	
Current $I_B$ at point B in mA	
Supply voltage $V_s$	

## Worksheet 6 - The fuse:

The voltage required to deliver a dangerous level of electric current depends on a number of factors including the electrical resistance of the human body. This, in turn, depends on factors like:

- the presence of sweat on the skin;
- the hydration level of the body - 45 to 70% of the weight of the body is water;
- the body fat content;
- where on the body the electrical contact occurs.

The resistance of the human body is typically between  $1k\Omega$  and  $100k\Omega$ .

In a 'short-circuit', worn or damaged insulation allows wires to touch, large currents can flow, causing a lot of heat. One precaution is to use a fuse - a short length of wire with a low melting point, which acts as the weak point in the circuit. A large current flowing through it heats it so much that it melts, breaking the circuit and stopping the current before it causes damage.

The diagram shows the circuit symbol for a fuse.

Complete the following statements:

- A fuse contains a fine metal wire. When the  flow of electricity gets too big, this wire gets so hot that the metal ....., and breaks.
- This creates an air ..... in the circuit, which stops the flow of electricity.
- This stops the other ..... in the circuit from getting too hot, and causing a fire.

In the UK, mains '13A' plugs contain cartridge fuses, with ratings of 3A, 5A and 13A.

### Calculating fuse values:

Use the formula  $P = I \times V$  (or  $I = P / V$ ) to work out the normal appliance current,  $I$ . Then we choose a fuse value just greater than this.

Calculate the normal current and then choose the best fuse rating for the following devices, when used on a 240V supply:

Appliance	Power rating (W)	Normal current (A)	Fuse
Reading lamp	60		
Kettle	2000		
Fire	3000		
Vacuum cleaner	1200		

## Worksheet 7 - The circuit breaker:

The circuit breaker (mcb) switches off the current when it senses a fault.

Like the fuse, it protects the appliance and the wiring connected to it. However, a fuse must be re-wired or replaced before normal operation can resume. The mcb can be reset, usually by pressing a reset button or operating a switch.

### Challenge:

Trip current for the circuit breaker = .....A



## Worksheet 8 - The RCD:

The **RCD** (residual current device) compares the current it supplies **to** the appliance with the current, which flows back **from** it. An imbalance might indicate a fault, such as an electric current flowing to earth through the user.

The RCD 'trips', shutting off the electricity supply to the appliance and the user.

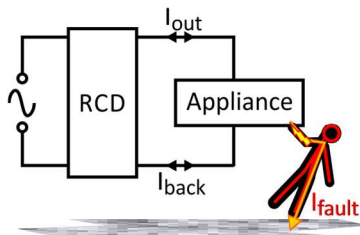

### Challenge:

Trip current for the RCD = .....mA

## Worksheet 9 - Solenoids:

One effect of an electric current is that it heats up the conductors that it flows through. Another is that it produces a magnetic field around that conductor. This magnetic effect is made stronger by winding the conductor into a coil. It is even stronger if the coil has a core of a material such as fer-rite. What did you see when:

- the switch was closed initially:

.....

- when the ferrite core was removed:

.....

- the current was reversed?:

.....

## Worksheet 10 - Relays:

The relay is another application of electromagnetism - a remotely controlled switch. Operated from a low voltage, low current control circuit, it can be used to switch large currents and high voltages, or can be used to operate devices in a hazardous environment from a safe distance.

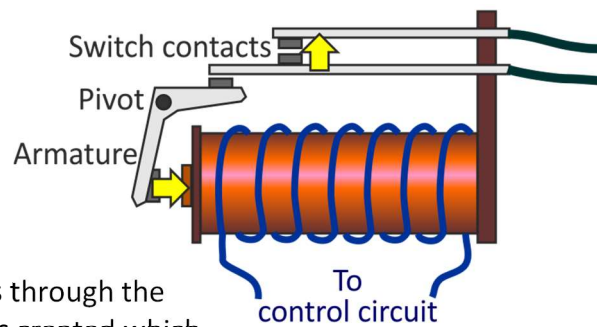

When a current flows through the coil, a magnetic field is created which magnetises the core.

This attracts a pivoted armature to it. As it moves towards the core, it rocks around the pivot and closes a pair of contacts in the process.

(Other forms of relay can open 'normally-closed' contacts or act as a changeover switch).

### Your results:

Current in control circuit (at point **A**) = ..... mA

Current in load (at point **B**) = ..... mA

# **Electrical Science and Technology Level 3**

## **Instructor Guide**

## About this course

### Introduction

The course is essentially a practical one. Where possible, practical implications and applications of the theory are highlighted to make the course more relevant to the students.

A Student Handbook is included to give students a concise record of their studies.  
Locktronics equipment makes it simple to construct and test electrical circuits.

### Aim

The course introduces students to concepts used in domestic and industrial electrical installation. It covers much of the content of the City and Guilds Level 3 Advanced Technical Diploma in Electrical Installation, complementing knowledge acquired on other Matrix courses such as LK2686 'Three Phase Systems'

### Prior Knowledge

It is recommended that students have followed the LK 4098 "Electrical wiring 1" course, or have equivalent knowledge and experience of building simple circuits, and using multimeters.

### Learning Objectives

On successful completion of this course the student will be able to:

- state that voltage and current are in phase in a resistor;
- describe the structure of an inductor and recognise its circuit symbol;
- describe the structure of a capacitor and recognise its circuit symbol;
- know that inductance is measured in a unit called the henry, (H) and that reactance is measured in ohms;
- know that capacitance is measured in farads (F), or microfarads ( $\mu\text{F}$ );
- know that the opposition of an inductor to changing currents is called inductive reactance;
- use the formula:  $X_L = 2 \pi f L$  to calculate inductive reactance;
- know that the opposition of a capacitor to changing voltage is called capacitive reactance;
- state that voltage lags behind current in a capacitor.
- use the formula:  $X_C = 1 / (2 \pi f C)$  to calculate capacitive reactance;
- use the formula  $X_C = V / I$ , where V and I are rms voltage and current respectively;
- calculate the voltage across a resistor using  $V_R = I \times R$  and across a capacitor using  $V_C = I \times X_C$ ;
- recall that impedance is the combined effect of resistance and reactance and is measured in ohms;
- use the formula  $Z = (R^2 + (X_L - X_C)^2)^{1/2}$ ;
- recall four factors that affect the electrical resistance of the human body;
- describe the principle behind the electrical fuse;
- describe what is meant by a 'short-circuit';
- calculate the suitable value for a cartridge fuse, given data on supply voltage and power rating for the device;
- explain why a fuse and circuit-breaker (MCB) offer protection for an electrical device but not for the user;
- compare the relative advantages of a fuse and circuit-breaker;
- measure the trip current for a MCB;
- distinguish between the function of a RCD and that of a fuse or MCB;
- recognise a solenoid actuator as an application of electromagnetism and set up a circuit to drive it;
- recognise a relay as an application of electromagnetism and set up a circuit to drive it;
- describe two situations in which a relay might be used;
- add a diode to an electromagnetic device such as a relay to protect against the effects of 'back e.m.f'.

## What the student will need:

To complete this course, the student will need the following equipment:

1	HP2045	Shallow tray
1	HP2666	DC power supply, variable
1	HP3728	AC power supply, 12V
2	HP4039	Tray lid
1	HP5540	Deep tray
2	HP7750	Daughter tray foam cut out
2	HP8600	Crash foam
1	HP9564	62mm daughter tray
1	LK0124	Compass
5	LK119-346	Wire wool packs
1	LK2340	AC voltage source carrier
3	LK2346	MES bulb 12V, 0.1A
1	LK3291	Ferrite rod
2	LK4002	100 ohm 1W, 5% resistor carrier
1	LK5203	1k ohm, 1/4W, 5%resistor carrier
1	LK5214	10kohm potentiometer
2	LK5243	diode, power 1A carrier
17	LK5250	Connecting links
3	LK5291	MES lampholder
1	LK5403	relay 6V coil, normally open
2	LK5603	lead, 4mm to 4mm, red
2	LK5604	lead, 4mm to 4mm, Black
1	LK5987	33uF capacitor carrier
1	LK6207	push-to-make switch carrier
3	LK6209	switch, on/off, carrier
1	LK6237	500ohm resistor carrier
1	LK6838	solenoid
1	LK7928	residual current device
1	LK7936	fuse/universal component carrier
1	LK8275	power supply carrier with battery symbol
1	LK8623	circuit breaker
1	LK8900	Locktronics Baseboard
1	LK9998	Coil carrier

## Using this course:

The experiments in this course should be integrated with teaching to introduce the theory behind it, and reinforced with written examples, assignments and calculations.

The worksheets should be printed / photocopied / laminated, preferably in colour, for the students' use. They should make their own notes, and carry out the tasks identified in the 'For your records' sections. They are unlikely to need their own permanent copy of the worksheets.

This format encourages self-study, with students working at a rate that suits their ability. The instructor should monitor that students' understanding keeps pace with their progress through the worksheets. One way to do so is to 'sign off' each worksheet, as a student completes it, and in doing so have a brief chat with the student to assess grasp of the ideas involved in the exercises it contains.

## Time:

It should take students between 5 and 8 hours to complete the worksheets. It is expected that a similar length of time will be needed to support the learning that takes place as a result.



Worksheet	Notes for the Instructor	Time
Preamble	<p>It is assumed that students are able to:</p> <ul style="list-style-type: none"> <li>• use a multimeter to measure the voltage across a component;</li> <li>• use a multimeter to measure the current through a component;</li> <li>• change the measurement range on the multimeter as appropriate;</li> <li>• understand and be able to manipulate multiples of units, such as milli, micro, kilo etc.</li> <li>• understand the significance of the superscripts “...<sup>2</sup>” and ‘...<sup>½</sup>’.</li> </ul> <p>The appendices help with the use of multimeters to measure voltage, current and resistance.</p>	
Introduction	<p>One of the challenges of this subject is to ensure that students know the difference between resistance, inductive reactance, capacitive reactance and impedance. In DC circuits, the only one present is resistance. In AC circuits, however, the situation is complicated. The good news - resistance is the same at all frequencies, including DC. The more difficult news, the others all depend on the frequency of the AC supply and depend in different ways.</p> <p>The student should know that resistance, reactance and impedance are similar quantities. They control current. The formula for impedance is quoted in this section but it is not expected that students be able to use it with understanding at this stage</p> <p>Capacitance and inductance (and ‘friction’ between electrons and the material that they flow through) give rise to reactance (and resistance). The combination of all resistance and reactance is called impedance.</p> <p>‘Capacitance’ describes the way in which electric fields control current. ‘Inductance’ describes the way in which magnetic fields control current. They should be seen as mirror-images of each other, in that , in a capacitor, the current leads the applied voltage (i.e. is a maximum when the voltage is zero, falls as the voltage rises...) whereas, in an inductor, current lags behind the applied voltage (is zero when the voltage is a maximum and then rises as the voltage falls).</p> <p>The instructor should ensure that students realise the significance of the graphs on page 4, in terms like those written alongside the graphs.</p> <p>The next section contrasts real and ideal components and the demands made by microelectronic systems on their design. Wire-wound resistors are essentially coils of resistance wire and hence have inductance as well as resistance. Capacitors are potentially large components. They are made smaller by rolling them up, like Swiss rolls, and by using extremely thin sheets of insulation between the plates. One consequence of the thin sheets is that the resistance of the insulation falls. Inductors are also potentially bulky components. Using thin insulated wire to form the coil reduces the physical size, but increases their resistance. For inductors to have an appreciable effect at mains frequency, they need a high inductance value. This means that a large number of turns of wire are needed on the coil - again increasing their resistance and size. ( A 1H inductor is typically 8cm x 4cm x 4cm and weighs around 500g - hardly a microelectronic component!)</p> <p>There is real difficulty in experimenting with inductors at mains frequency, as the text points out. Their reactance at low frequencies is small and is usually swamped by the effect of their resistance, as the calculations on page 5 illustrate. For that reason, this module focuses on capacitive reactance - much easier to demonstrate and manipulate at low frequencies.</p>	15 - 25 mins

Worksheet	Notes for the Instructor	Time
1	<p>The aim is to reassure students that what they learned about ‘good-old-resistors’ is equally true, probably, in both AC and DC circuits.</p> <p>To begin with, they measure the AC voltage applied to a resistor and the resulting current and use the Ohm’s law formula to calculate the resistance of the resistor. (It is not necessary to go into detail about the measurement process. The reading can be referred to as an ‘average’ or as the DC equivalent, rather than r.m.s.)</p> <p>The ‘So what’ section details Ohm’s law as both a graph and as a description. The second graph illustrates the difference between big and little resistors, though students should be careful about how they interpret these graphs. The results depend on which quantity is plotted on the vertical axis.</p>	20 - 30 mins
2	<p>The aim is the same as in worksheet 1 - to show that AC or DC doesn’t matter to resistors. This worksheet also serves as revision of a topic that the students may have looked at a long time ago.</p> <p>The introduction reminds them of the difference between series and parallel connections. The instructor may wish to distinguish between ‘parallel’ as used here and ‘parallel’ as used in geometry. In electronics, a parallel connection is one which has junctions, allowing choice of route to the current.</p> <p>Students measure the total current through and voltage across the combinations so that they can calculate the total (effective, equivalent, combined) resistance.</p> <p>They then compare practical values with those obtained using theoretical formulae. The Student Handbook asks them to account for any differences. This can be done as a class discussion, raising issues like component tolerance, meter accuracy etc.</p>	20 - 30 mins
3	<p>This worksheet introduces the capacitor. The hurdle is the distinction between capacitance and capacitive reactance, as was pointed out in the Introduction.</p> <p>Outlining the process by which a capacitor impedes the flow of current will help. Although this includes electric fields, a piece of physics ‘magic’, the mechanism is relatively straightforward. The analogy with a bucket should be developed.</p> <p>Here is another opportunity to hammer home the meaning of prefixes, in this case ‘micro’. This may cause grief for students with limited mathematical ability or experience but they need to grasp it. Looking at the ‘exchange rates’ between ‘micro’, ‘nano’ and ‘pico’ provides good practice.</p> <p>As with most concepts, there are two ways to obtain capacitive reactance - from theoretical formulae or by measurement. Both have limitations and the student is asked to compare values obtained from each route.</p> <p>By comparing the results for a large and a small value of capacitance, students see that capacitive reactance is smaller for the larger value capacitor, at the same frequency.</p>	20 - 30 mins

Worksheet	Notes for the Instructor	Time
4	<p>Students will probably have met voltage dividers in their earlier studies. (If not, the instructor will need to spend time on this topic before the students tackle this investigation.) This takes the concept one step further, to a voltage divider where the way the voltage is shared depends on the frequency of the supply. This can lead to a discussion about filters, where high (or low) frequencies generate higher voltage across one of the components than across the other.</p> <p>The treatment raises the idea of a phase difference between current and voltage in the capacitor, but not in the resistor. This seriously complicates the analysis of the circuit and requires us to calculate the impedance of the capacitor - resistor combination. In a series circuit, the current is the same everywhere (where else are the electrons to go?). It is current that binds together the treatment of the circuit. The current is the same but the voltage across the components depends on their resistance and reactance.</p> <p>The 'So what' section shows how to calculate first the capacitive reactance and then the impedance of the combination. This is then used, in the Student Handbook, to calculate theoretical values for the voltages across the capacitor and resistor. These are then compared with the measured values.</p>	20 - 30 mins
5	<p>This time, the components are connected in parallel. This means that they have the same voltage across them, but the current they pass depends on their reactance (and hence the supply frequency).</p> <p>Rather than being a voltage divider, this is a current divider:</p> <ul style="list-style-type: none"> <li>• the phase relationships between current and voltage are the same as before;</li> <li>• the relative sizes of current through them depends on the relative sizes of the resistor and capacitive reactance;</li> <li>• the currents are not in phase with each other.</li> </ul> <p>Although the total current is difficult to calculate, we can use the values of resistance and reactance to calculate currents in the individual components. The Student Handbook guides us through this process.</p> <p>Once again, the theoretical and measured values can then be compared.</p>	20 - 30 mins
	<p>The overall phase angle between current and voltage is significant in industry, where the electricity supply company assume that they are in phase. Where they are not, the company will pay more for their electricity supply than they need.</p> <p>Inductive loads, such as high power electric motors, use added capacitors for power factor correction. For a motor, the value of capacitor needed to do this depends on aspects like the speed of the motor, its load and the frequency of the supply. This causes complications when there are a number of motors on the same power supply and when their speed and loads vary.</p> <p>The issue of power factor correction is covered in the module LK2686 'Three Phase Systems'.</p>	

Worksheet	Notes for the Instructor	Time
6	<p>The course starts with a reminder of how dangerous electricity can be and how small the current that could be fatal. However, it is not 'voltage' that kills, but current. A high voltage source which can deliver only a small current can be painful, but not fatal. An important factor is the resistance of the human body and some of the factors that affect this are listed.</p> <p>This worksheet then focuses on circuit protection and, in particular, the fuse. A fuse is the weakest link in the circuit. If anything melts, it is the fuse. In the process, a layer of insulating air is placed in the circuit and the current stops.</p> <p>The fuse is a device for preventing fires, and for protecting electrical equipment, not a means of preventing electric shock. The human body has such a high resistance that, when touching a high voltage wire, a very small current flows - sufficient to cause serious injury, but insufficient to 'blow' the fuse. Devices such as the earth wire, and RCDs protect against electric shock.</p> <p>The instructions ask the student to touch the flying lead momentarily across the lamp to cause a short-circuit. If the steel wool 'fuse' does not melt as a result, then probably the student has clamped too many strands between the posts of the sampler. (Use a piece of damp paper or cardboard to protect the baseboard from molten metal.)</p> <p>The 'So what' section gives more detail about short-circuits and introduces the cartridge fuse as a safety device to reduce the risk of fire. It would be helpful if some examples of different types and ratings of cartridge fuse were available for the student to inspect. The section then shows how to calculate the appropriate fuse value for a given device, based on its power rating (and voltage, assumed to be the UK mains supply of 240V.</p> <p>In the corresponding section of the Student Handbook, the student calculates suitable fuse values for a range of appliances.</p>	20 - 30 mins
7	<p>The next topic is the circuit breaker, also called the MCB, (miniature circuit breaker.) Once again, students should be shown examples having different current ratings. Some of the relative advantages of fuses and circuit breakers are discussed.</p> <p>The investigation shows how the circuit breaker allows normal operation of a circuit, but 'trips' when an abnormally high current flows, initiated in this case by short-circuiting the power supply.</p> <p>The student is asked to modify the circuit by replacing the switch with a variable resistor in order to measure the minimum current that causes the circuit breaker to trip. As no layout is given for this extension, the instructor may need to check the layouts and offer help to some students. Verbal assistance could point out that a variable resistor uses only two of the four 'legs' on the variable resistor carrier.</p> <p>The Student Handbook summarises information about the circuit breaker.</p>	20 - 30 mins

Worksheet	Notes for the Instructor	Time
8	<p>The third safety device, the RCD, has a different function. It protects the user against electric shock.</p> <p>The fuse and circuit breaker look for abnormally large currents, but the RCD senses a current imbalance, between the current leaving it and returning. It trips just in case this is caused by current flowing to earth through the user.</p> <p>Its behaviour is shown using an electric circuit having three lamps connected in parallel and independently switched, rather like a domestic lighting circuit. An imbalance is introduced by allowing some current to bypass the RCD device via a switch and a resistor (representing a human body).</p> <p>The challenge is to measure the minimum current needed to trip the RCD. Again, this uses a variable resistor. Once again, instructor intervention might be needed to set this up. As before, the Student Handbook offers a summary.</p>	20 - 30 mins
9	<p>Both the circuit breaker and RCD are applications of electromagnetism.</p> <p>This worksheet demonstrates the magnetic effect that always accompanies an electric current, using a DC power supply, as the magnetic field associated with AC changes constantly, with the current. A coil is used, rather than a single wire, to intensify the magnetic field. The ferrite core does the same thing, as the student should see when the core is removed later in the investigation.</p> <p>If there is no effect when the switch is closed, the cause may be the orientation of the board. The solenoid's magnetic field might just be lined up with that of the Earth! Try rotating the baseboard through <math>45^\circ</math>. The student then reverses the current through the solenoid by inverting the power supply carrier and looks for a corresponding effect on the compass.</p> <p>Finally, the student sets up a circuit to operate a solenoid actuator. For the same reason as above, this requires a DC power supply. Essentially the same as the solenoid, this has a plunger which, magnetised by the magnetic field, moves into or out of the solenoid, driven by magnetic attraction / repulsion.</p> <p>The lamp confirms that a current flows when the switch is closed. Again, results are recorded in the Student Handbook.</p>	30 - 40 mins
10	<p>Another application of electromagnetism, the relay is widely used either as a remote-controlled switch or to control high current / high voltage applications using a safe low current control circuit.</p> <p>The instructor could expand on the operating principle. In particular, students should know that the contacts switched by the device are insulated from the rest of the relay. A collection of relays will help the students' understanding and also show that relays come in a vast range of shapes and functions.</p> <p>In designing relay circuits, the switch contacts are all that appear in the load circuit. Unusually, perhaps, in this system the load is connected to the same supply as the control circuit. More often, the load will have its own separate supply, which could be AC or DC and which could offer a different voltage.</p> <p>Both relay and solenoid involve strong magnetic fields. When energised, they store considerable energy. When switched off, the magnetic field collapses and generates a high reverse voltage in the coil, which can damage components in the control circuit. Silicon diodes are connected 'in reverse' to conduct this energy away safely, exposing the components to nothing more than 0.7V.</p> <p>The Student Handbook summarises this worksheet.</p>	30 - 40 mins

# Change log



05 08 19	Small BOM changes JD.
30 11 20	Formatted BOM differently. JD
16 08 23	Reformatted to new style