

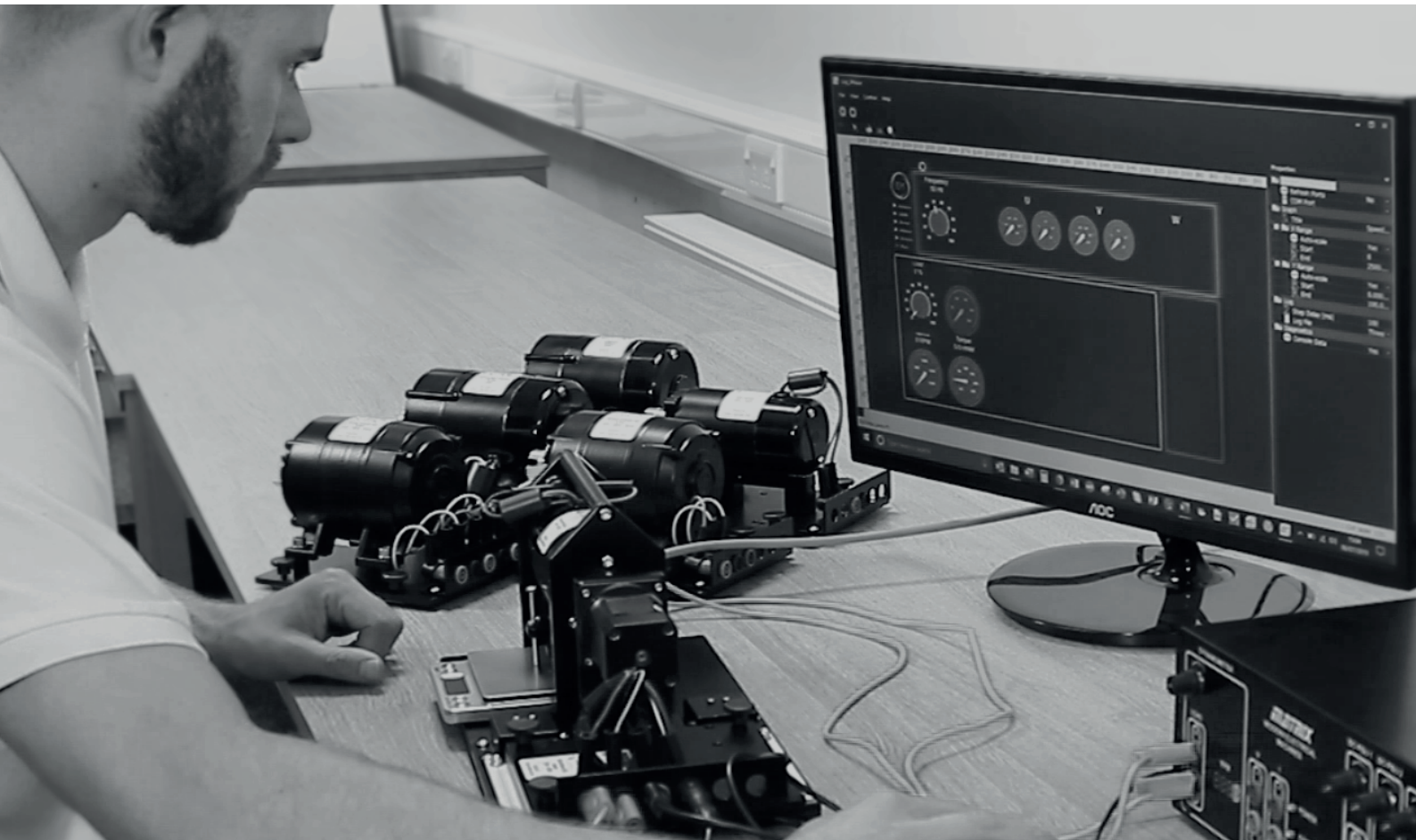

ELECTRICAL MACHINES



Modern electrical machines

Training equipment for the study of modern motor characteristics



www.matrixtsl.com

MATRIX

Modern electrical machines

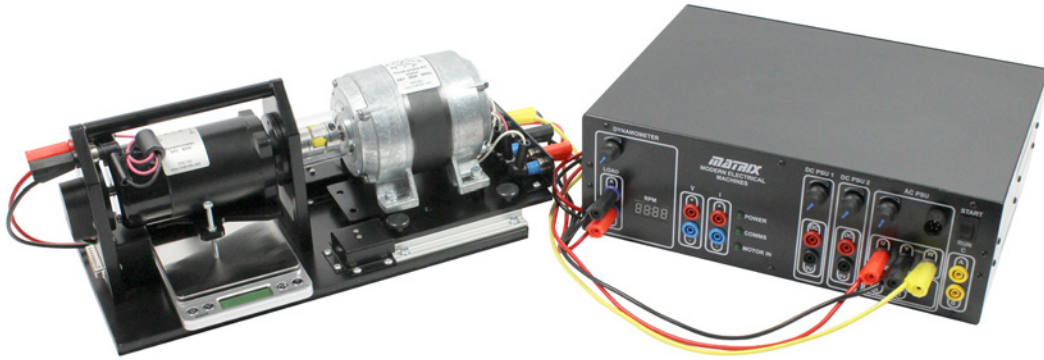

Our modern electrical machines training system is a revolutionary way of safely studying the characteristics of different motor types in a learning environment. This solution includes eight different types of machine, integrated power supply and control box and PC-based applications for advanced controller of the different machine types. Further to this, we provide four separate curriculum manuals for teaching electrical machines principles using manual control with external meters, using PC control or using MATLAB.

Learning objectives / experiments:

- It's safe to operate – all moving parts covered
- The system operates on 24V power, AC or DC
- All machines are small footprint, low power
- The system is easily stored and packed away
- Includes electronic measurement of voltage, current and power in AC and DC
- Both manual and full PC control
- DC power supply is included
- AC power supply single and three phase supply with variable frequency is included
- Full curriculum and experiments are included

This kit includes:

- Dynamometer with integrated load cell and rotary encoder
- DC Permanent Magnet Motor (also used as a DC Permanent Magnet Generator)
- DC Shunt Motor (also used as a DC Separately Excited Motor & Generator and DC Shunt Generator)
- DC Series Motor (also used as an AC / Universal Motor)
- AC Single Phase Induction Motor
- AC Three Phase Induction Motor (Star and Delta configurations)
- Brushless DC Motor (also AC Three Phase Permanent Magnet Synchronous Motor & Generator)
- Integrated power supply and control box
- PC-based applications for advanced control of the motors

Control box

At the heart of both manual and PC control of the machines is our control box. The control box houses all of the electronics including motor drivers, to control the modern electrical machines training system.



Control box features

- Select DC, single-phase AC and 3-phase AC outputs
- Integrated voltage and current measurement
- Adjustable resistive loads for dynamometer and series winding resistor
- Switchable start and run capacitor
- 14 different instruments embedded within it
- A unique API, allowing connection to be made to the MATLAB environment
- A small size, around the size of a laptop, making it small enough to sit on a desk along with the rest of the kit and PC

Modern electrical machines

Motors

DC Dynamometer / motor and cradle

Operating voltage – 24V AC
Max current - 2A
Speed – 1500rpm

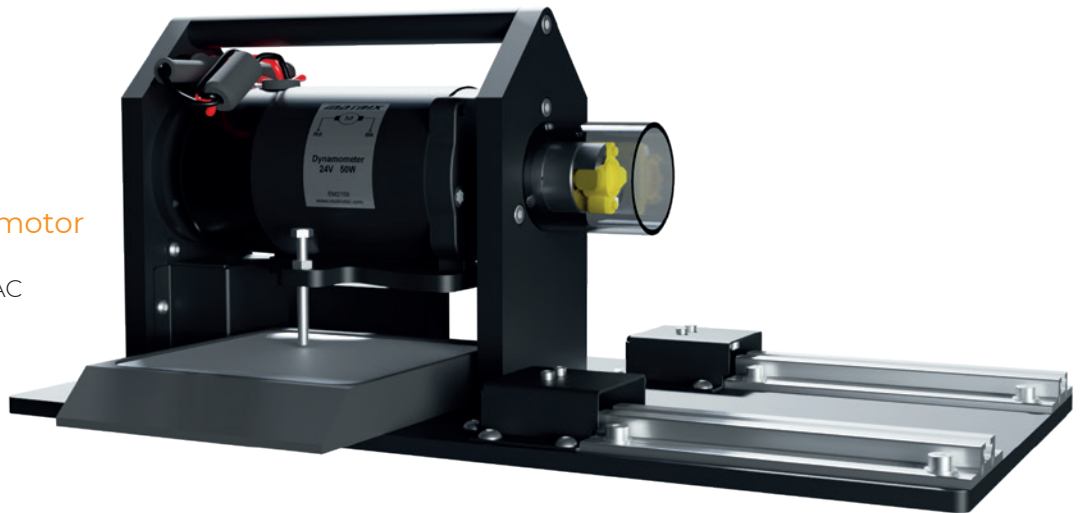

The aluminium cradle which houses our dynamometer features a rugged and safe sliding mechanism into which each of the other six motors in the range fix into position. The motor coupling meets the dynamometer in a protected housing and allows for safe study of each machine type at 24 volts. When using our system in manual mode, it is likely you will require two (per set) HP1324 Fluke 115 True RMS Digital Multimeter and one HP8067 Tektronix Digital oscilloscope.

Three phase induction motor

Operating voltage – 24V AC
Frequency – 40-80Hz
Max current – 1.4A
Speed – 1400rpm

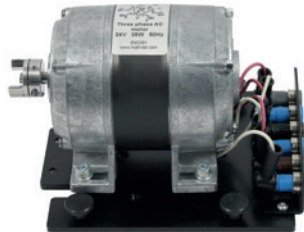

Shunt motor

Operating voltage – 24V AC
Max current – 12A
Speed – 1500rpm



Single phase induction motor

Operating voltage – 24V AC
Frequency – 40-80Hz
Max current – 1.4A
Speed – 1400rpm



Universal / Series motor

Operating voltage – 24V AC
Frequency – 50Hz
Max current – 6A
Speed – 1500rpm



DC motor

Operating voltage – 24V AC
Frequency – 40-80Hz
Speed – 1500rpm



Brushless DC motor / 3 phase generator

Operating voltage – 24V AC
3 Phase
Max current – 2A
Speed – 1500rpm



Modern electrical machines

PC Software

The system is designed to be used manually or via connection to a laptop or PC. When utilising the PC control option, the user should download the app from the Resources page on the website. Above are a range of screenshots showcasing the ways the proprietary software can be used to control each type of machine in the range.

Through experimentation, users can review the results of altering the voltage, load etc of each machine and the subsequent effect this has on each machine's current, torque etc. over time.

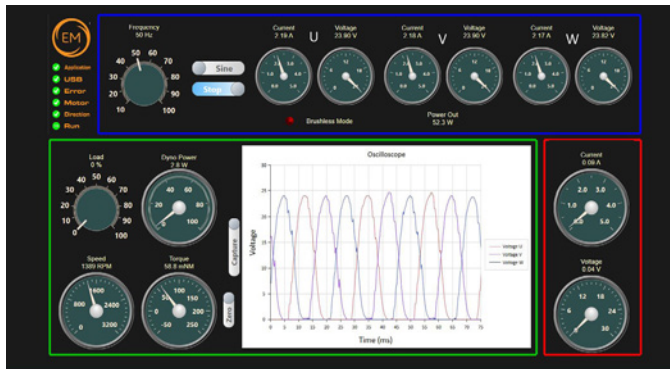

Three phase control software with integrated oscilloscope.

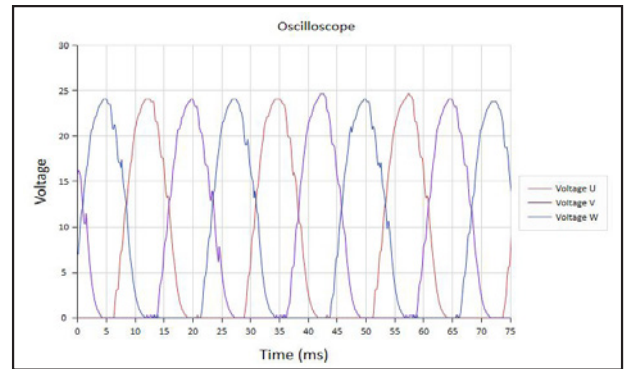

Close up of oscilloscope plot – users can select from one of 14 on-board instruments.

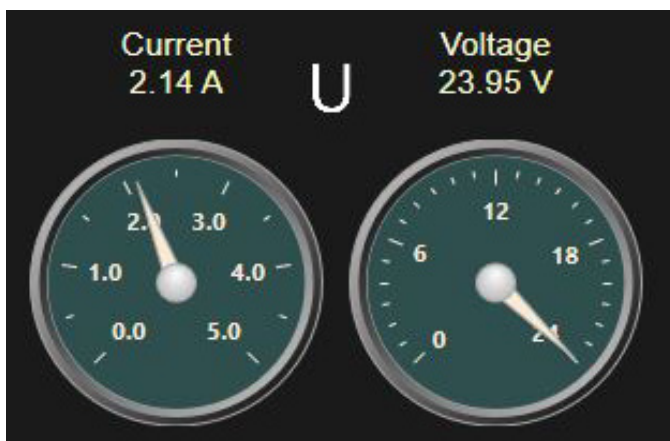

Gauges show key values such as current and voltage.

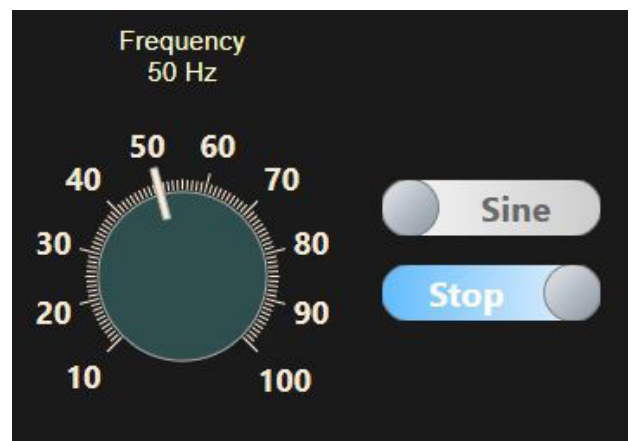

Set output frequency and waveform type – in this case digital or pseudo-sine.

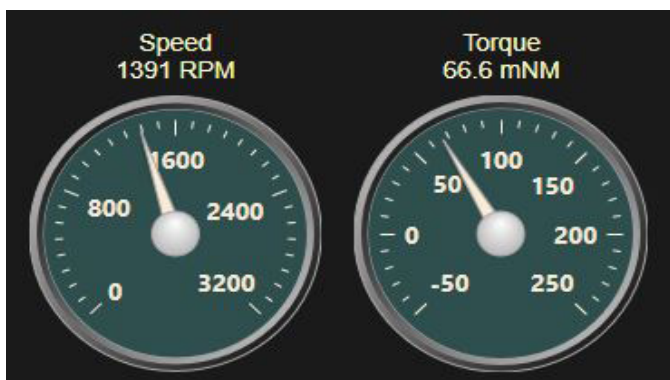

Software allows you to monitor RPM and torque in real time.

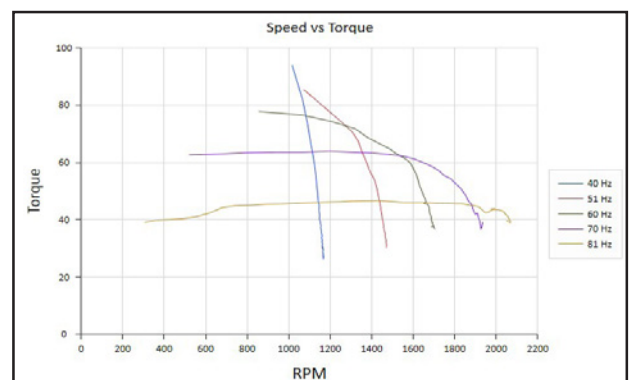

Automatic speed torque graph for any of the machines can be generated by the software.

Modern electrical machines

Optional Add Ons

Transformer Add On - EM4425

This add-on allows users to add transformer construction study to the electrical machines system from Matrix. With this kit, students can study:

- Open and short circuit characteristics of transformers
- Circuit modelling of transformers using MATLAB or LabVIEW

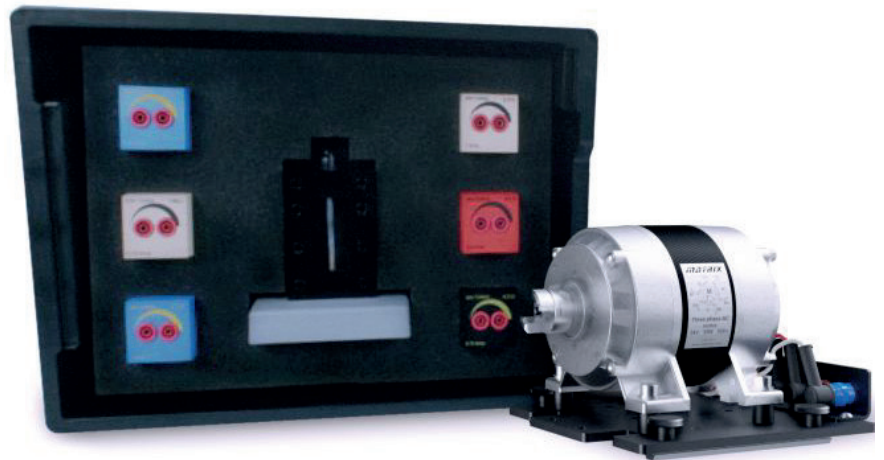

Locked Rotor Add On - EM2551

This add-on allows users at add advanced level to study the electrical machines system from Matrix. With this kit, students can study:

- Open and short circuit characteristics of induction motors
- Circuit modelling of induction motors using MATLAB or LabVIEW

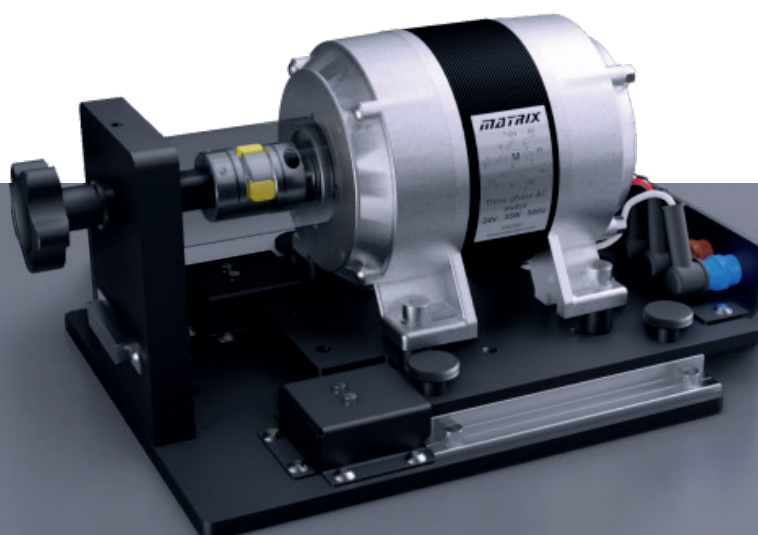
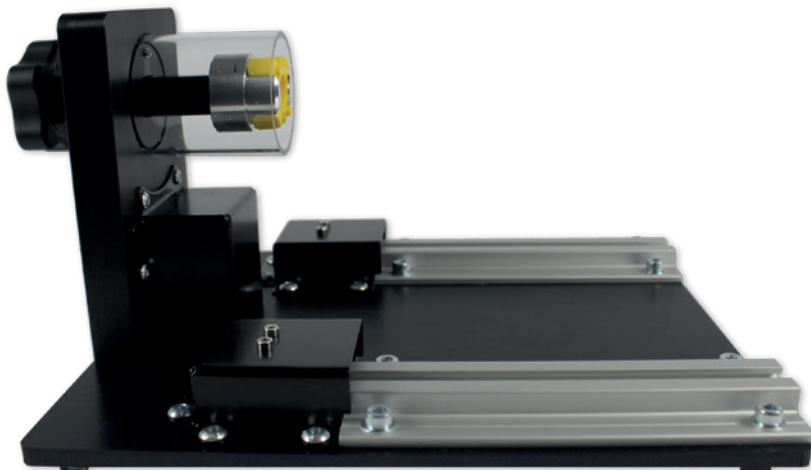

Modern electrical machines

MATLAB and LABVIEW

A suite of API calls are provided which allows the system to be used with both MATLAB and LabVIEW software.

This allows students to understand the characterisation of electromechanical systems using mathematical formulae and to compare simulated results with real world values.

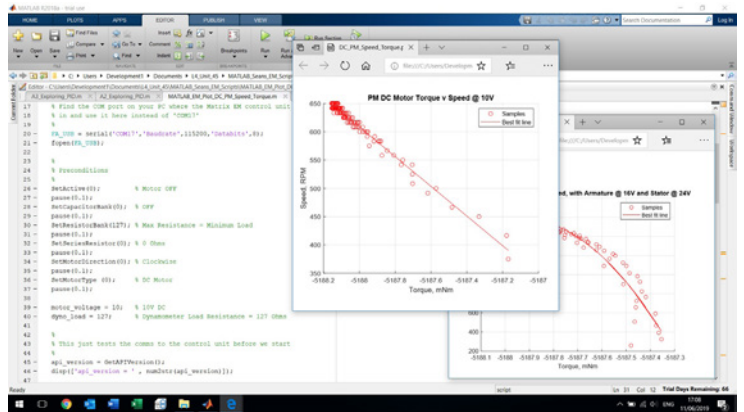
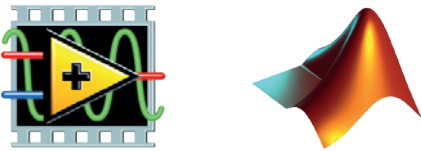

Curriculum

We have created 4 curriculum to go with our range of modern electrical machines. They follow the learning required within different courses and come complete with learning instructions, worksheets and a teachers section. They come equipped with all the learning required for the course, along with the software required.



Curriculum mapping

- Teaches students the basics of electrical machine operation, their speed / torque characteristics, relevant mathematical relationships including torque, power, and slip, and details of the circuits and power supplies needed to drive them.



Curriculum mapping

- Teaches Electrical Installation students the basics of electrical machine operation, their speed / torque characteristics and the circuits and power supplies needed



Curriculum mapping

- Teaches students how to use MATLAB to measure the characteristics of electrical machines, how to define the characteristics using a mathematical model and to verify that model using test results.



Curriculum mapping

- Introduces students to more advanced concepts and models of electrical machines and focuses particularly on building equivalent circuits of machines.



"As with all Matrix solutions, our electrical machines kit is provided with storage trays, to ensure minimal lab space is taken up."

Ordering information	
Modern electrical machines	EM6637
Corresponding curriculum	CP6490, CP4160, CP8385,
You will also need	
Fluke 115 True RMS Digital Multimeter	HP1324
Tektronix Digital Oscilloscope	HP8067
COMING SOON	
Electrical machines servo & pendulum	EM3967
Electrical machines locked-rotor add-on	EM2551



ELECTRICAL
MACHINES

MATRIX

www.matrixtsl.com



Matrix Technology Solutions

The Factory, 33 Gibbet Street, Halifax, HX1 5BA, United Kingdom

t: +44 (0) 1422 252380 e: sales@matrixtsl.com