

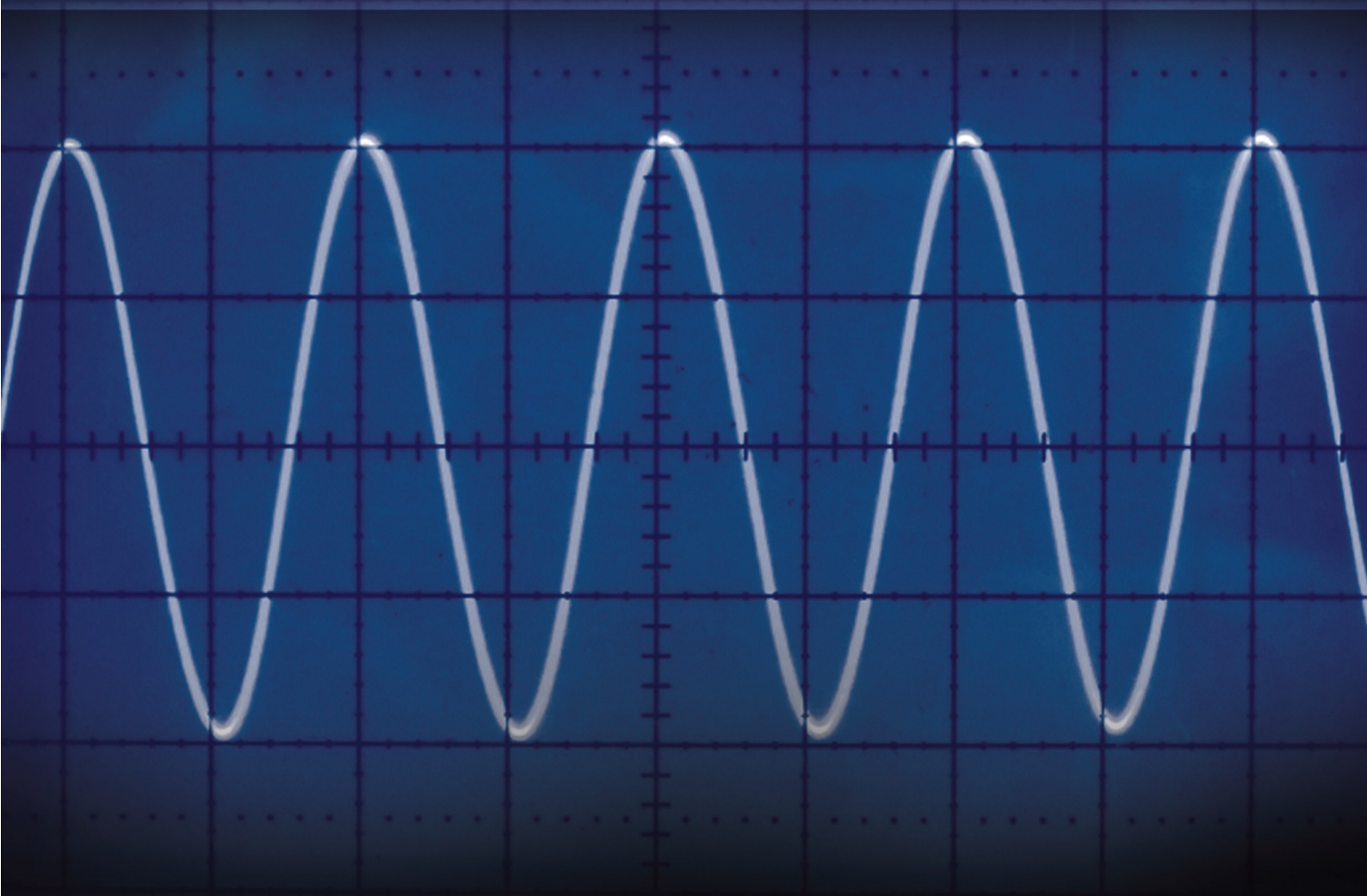

Simplifying Electricity

**AC principles for automotive technicians**



LK8392

**MATRIX**  
www.matrixmultimedia.com

Copyright © 2009 Matrix Multimedia Limited

# Contents

## AC principles for Auto technicians

Worksheet 1 - Auto Electrics	3
Worksheet 2 - AC vs DC	5
Worksheet 3 - Diodes	7
Worksheet 4 - Half-wave rectifier	9
Worksheet 5 - Full-wave rectifier	11
Worksheet 6 - Ripple voltage	13
Worksheet 7 - Inductors	15
Worksheet 8 - Capacitors	17
Instructor's Guide	19
Picoscope Help	27

**About this document:**

Code: LK8392

Developed for product code LK8222 - AC principles for automotive technicians

Date	Release notes	Release version
01 05 2010	First version released	LK8392-80-1 revision 1
08 06 2010	Amendments following external review	LK8392-80-1 revision 2

# Worksheet 1

## Auto Electrics

## AC principles for Auto technicians

The lead-acid battery often takes centre-stage when we talk about automotive electrics. It delivers DC (direct current) power, at close to 12V.

However, there are other important elements - the electronic ignition system which generates the

high voltages needed to fire the spark plugs, the high voltage HID headlights, the alternator, rectifier and voltage regulator that generate AC (alternating current) and then convert it to DC, the Controller Area Network (CAN) that allows switches and sensors to communicate with each other and with the ever increasing number of other electronic devices incorporated into the electrical system.

In reality, AC electricity plays an important part in the operation of the modern car. We start off this course by reviewing some aspects of AC, and then comparing it with DC.

To do so, we need equipment to generate and to examine AC signals—a signal generator and oscilloscope respectively. The operating details of these devices vary between manufacturers and even between models. In this course we focus on the use of a PC based Virtual Oscilloscope to examine AC signals—a Picoscope. Its operation is detailed in the last 2 pages of these worksheets.

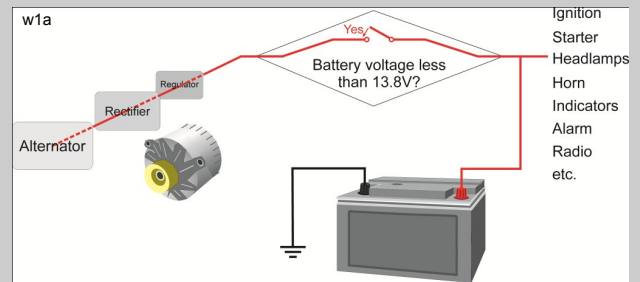

### Over to you:

Set the DC power supply to 9V. Connect an oscilloscope to the supply as shown in the photograph opposite.

Close the switch and record the DC trace seen on the screen.

Now swap the DC power supply for an AC power supply of between 8 and 13V AC. The AC supply's output is radically different from the 9V DC power supply you just examined.

Connect an oscilloscope to the AC supply, close the switch, and record the AC trace seen on the screen.

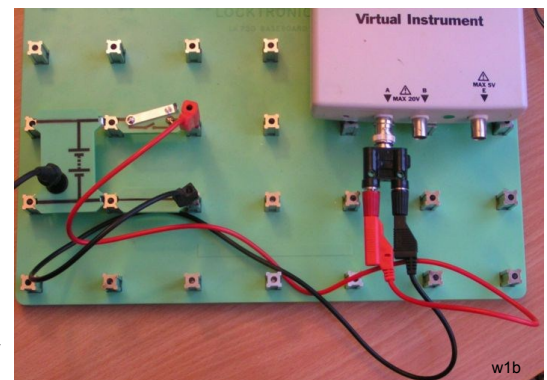

### The settings for the oscilloscope are:

**Timebase** - 5ms/div (X multiplier x1)

**Voltage range** - Input A -  $\pm 20V$  DC (Y multiplier x1)

**Trigger Mode** - Repeat      **Trigger Channel** - chA

**Trigger Direction** - Rising      **Trigger Threshold** - 200mV

# Worksheet 1

## Auto Electrics

## AC principles for Auto technicians

### So what?

The top picture shows a typical trace for the output of the DC supply. Notice that this voltage is constant over time.

Use **your** trace to measure the output from the DC supply, and record the result in the table.

Measurement	Value
DC supply output voltage	V

The second picture shows a typical trace for the AC power supply. This shape is known as a **sinusoidal** (or sine-wave) signal. Make sure you are clear about this trace. The voltage changes direction when the trace crosses 0V. The time taken to produce one cycle (i.e. one peak plus one trough) is known as the **period** of the AC signal, and is measured in seconds. The number of cycles produced per second is known as the **frequency** of the AC signal, and is measured in hertz. (1 Hz means one cycle produced every second.) This can be calculated using the relationship:

$$\text{Frequency} = 1 / \text{period}$$

The third picture uses arrows to identify the peak voltage (or amplitude), A, and period (P) of the signal. Use **your** trace to measure these quantities and record the results in the next table. Use your value of period to calculate the AC frequency, and record that too.

DC supply

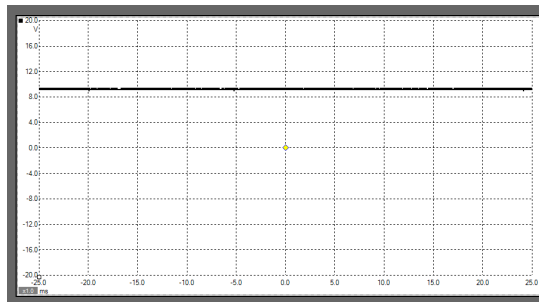

w1c

AC supply

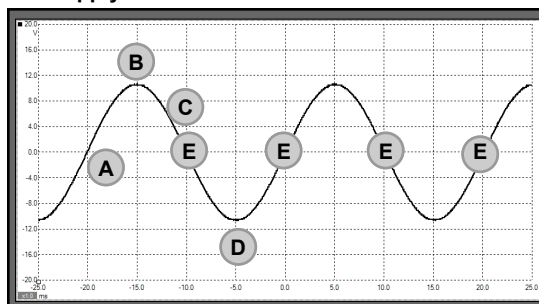

w1d

- A Voltage increasing
- B Maximum positive voltage
- C Voltage decreasing
- D Maximum negative voltage
- E Voltage changes direction

AC supply

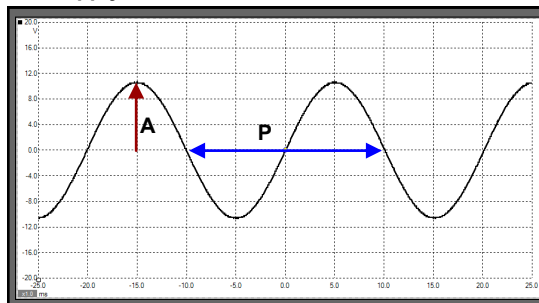

w1e

- A Amplitude
- P Period

Measurement	Value
Amplitude of AC signal	V
Period of AC signal	s
Frequency of AC signal	Hz

### For your records:

- The shape of AC signal delivered by AC power sources is called **sinusoidal**.
- The time taken to produce one cycle (i.e. one peak plus one trough) of the AC signal is known as the **period** of the signal, and is measured in seconds.
- The number of cycles of the AC signal produced per second is known as the **frequency** of the signal, and is measured in hertz.
- Period and frequency are related by the equation:  $\text{Frequency} = 1 / \text{period}$



# Worksheet 2

## AC vs DC

## AC principles for Auto technicians

Most of the auto electrical system uses DC. The current always flows in the same direction. One terminal of a device is always more positive than the other.

The alternator, on the other hand, generates AC. The current flows first one way and then the other. Does this mean that the effects cancel out? The answer is definitely 'no'. Our household electricity relies on AC. Our lights still light, washer motors still run, electric heaters still get hot, even though they are using AC.

The question is - how do AC and DC compare? Which AC measurements tell us how much power or energy to expect?

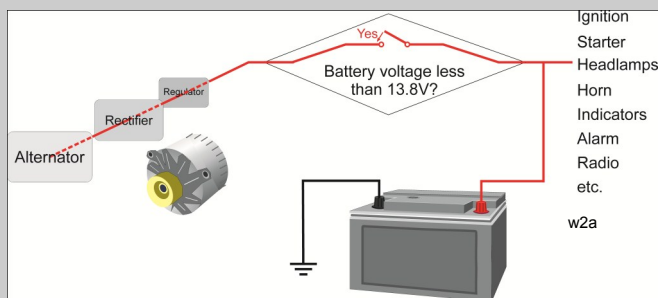

### Over to you:

Set up the circuit shown in the top diagram. This uses the DC power supply, set to give a voltage of 6V, and two lamps containing 6V 0.04A bulbs.

Close the switch. The two lamps should light, and be of equal brightness. If necessary, change a bulb until you find two that match and give equal brightness.

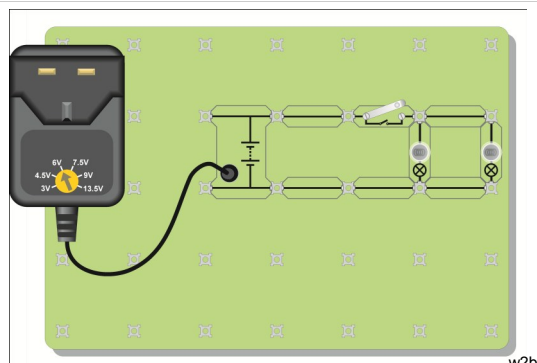

Now set up the two circuits shown in the lower diagram. Lamp A is powered by the 6V DC source, and lamp B by an AC power supply.

Adjust the 'pot' until the two bulbs are the same brightness. In this position, the AC voltage across lamp B has exactly the same effect as the DC supply across lamp A.

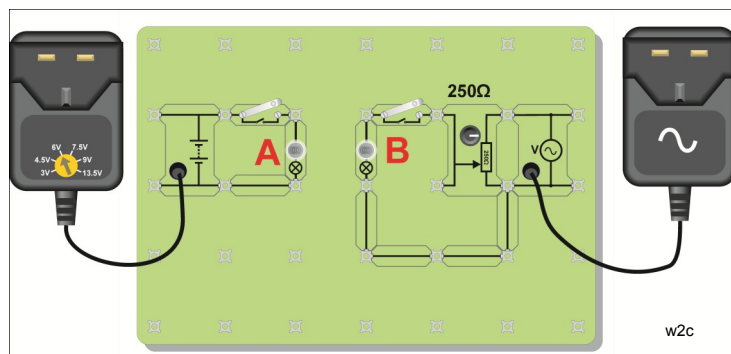

Connect a multimeter, set to the 20V DC range, to read the voltage across lamp A. Record the measurement in the table. This is the RMS value of the AC voltage.

Measurement	Value
DC voltage across lamp A	V

Now connect an oscilloscope across lamp B, and record the AC signal across it. (Note that the image shows a 'plug top' AC power supply; a conventional AC signal generator/power supply can also be used.)

**Oscilloscope settings** - same as worksheet 1:

- Timebase** - 5ms/div (X multiplier x1)
- Voltage range** - Input A -  $\pm 20V$  DC (Y multiplier x1)
- Trigger Mode** - Repeat      **Trigger Channel** - ch A
- Trigger Direction** - Rising      **Trigger Threshold** - 200mV

# Worksheet 2

## AC vs DC

## AC principles for Auto technicians

### So what?

The investigation you carried out showed that the AC supply to lamp B had the same effect as the 6V DC supply - both lamps had the same brightness.

We can put this another way: the **RMS** value of the AC supply was 6V. Although RMS stands for 'root-mean-square', it is more useful to consider it as the DC voltage that would produce the same effect as the AC supply.

The oscillogram shows a typical AC trace.

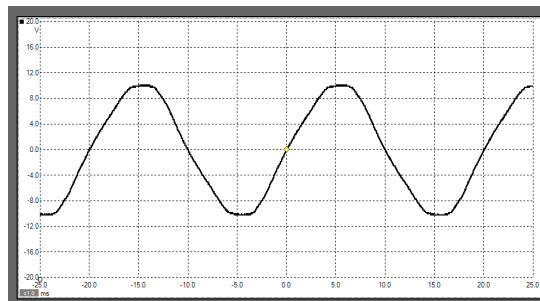

w2d

The RMS value, 6V, does not leap out as an obvious characteristic of this trace.

We obtain it in the following way:

- Measure the peak voltage (amplitude) shown on the trace, and record it in the table.
- Then, divide this peak value by the square-root of 2 (1.4 approximately,) and write your answer in the next row of the table.

Measurement	Value
Peak AC voltage across lamp B	V
Peak value AC voltage / $\sqrt{2}$	V

- You should find that the result is very close to 6V.

This relies on the result, obtained using mathematics, that for a sinusoidal signal:

$$V_{\text{RMS}} = V_{\text{PEAK}} / \sqrt{2}$$

(The result does **not** depend on the frequency of the AC, but does depend on the 'shape' of the signal. For a square wave signal that changes from 0V to  $V_{\text{PEAK}}$ , the formula is:

$$V_{\text{RMS}} = V_{\text{PEAK}} / 2 )$$

### For your records:

- The RMS (root-mean-square) value of a sinusoidal AC signal gives the equivalent DC voltage which has the same effect. To replace an AC power source, which has a RMS voltage of 12V, you could use a 12V DC source instead.
- The RMS and peak values of a sinusoidal AC signal are related by the relationship:

$$\text{Peak value} = \text{RMS value} \times \sqrt{2}$$

# Worksheet 3

## Diodes

## AC principles for Auto technicians

Most people have heard of Ohm's law. It describes a very straightforward link between voltage and current: - *double the current, and you double the voltage;*  
*quarter the current, you quarter the voltage - and so on.*

Very few components actually behave in this way. Resistors do, (providing they do not get hot;) diodes do **not**.

There are two common forms of diode - the power diode and the light-emitting diode (LED).

Both have a place in auto electrical systems:

- the power diode is used as a rectifier - to turn AC power from the alternator into DC.
- LEDs are used in warning lamps, brake lights, side lights and even headlamps.

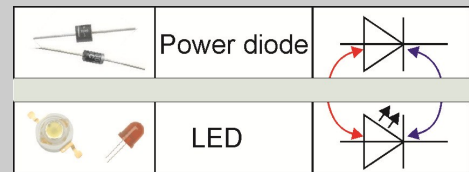

### Over to you:

Set up the arrangement shown in the circuit diagram. One way to do this is shown in the second diagram. **Make sure that the DC power supply is set to 3V.**

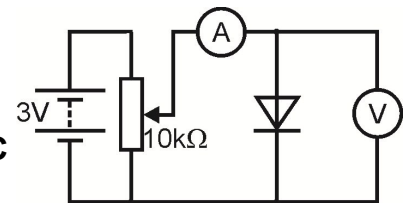

The variable resistor allows us to change the voltage applied to the diode. Notice that the anode is connected to the positive end of the power supply. We say that the diode is **forward-biased**.

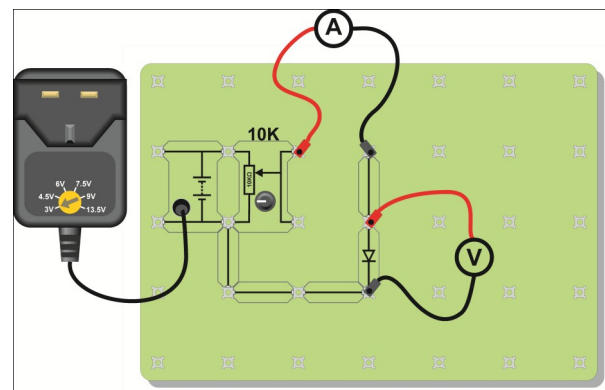

Make a results table like the one shown below. **Before you switch on**, select the **200mA DC** range on the ammeter, and the **20V DC** range on the voltmeter. Turn the knob on the variable resistor fully anticlockwise, to set the supply voltage to zero. Then turn the knob slowly clockwise until the current through the diode reaches 2.0mA. Read the voltage across the diode, and write it in the table.

Current through diode	Voltage across diode
2.0mA	
4.0mA	

Turn the current up to 4.0mA. Take the voltage reading again, and record it in the table. **Be careful - turn the knob on the variable resistor very gently.** The current changes rapidly for a tiny change in voltage. Keep increasing the current in 2mA steps, up to 20mA, taking the voltage reading each time, and recording the results.

Now, turn the voltage down to zero, and switch off the power supply. Remove the diode from the circuit, and replace it the other way round. We say that the diode is now **reverse-biased**.

Switch on the power supply. Turn the knob on the variable resistor slowly to its maximum value. Notice that hardly any current flows as you do so.

# Worksheet 3

## Diodes

## AC principles for Auto technicians

Plot a graph for the results recorded in the table i.e. forward-bias. (There is no need to plot a graph for reverse-bias.) Draw a smooth curve, like the one shown, using your plotted points as a guide.

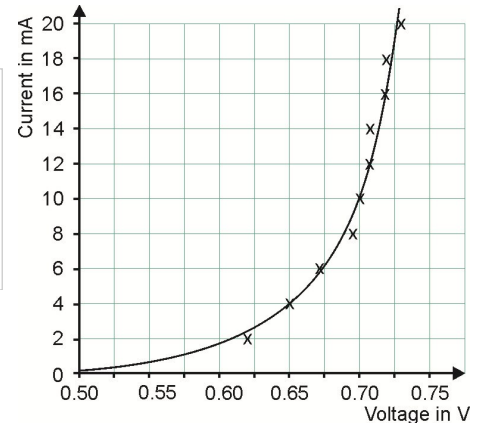

w3d

### So what?

The diode is a 'one-way valve'. It allows current to flow through it in one direction only. When it is forward-biased, it conducts, with a voltage drop of about 0.7V across it. When it is reverse-biased, it does not conduct (for low voltages.) (A resistor allows current to flow equally whichever way you connect it.)

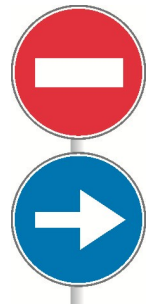

w3e

### For your records:

Copy the diagrams.

The first shows the circuit symbols for diodes and LEDs. The second shows the difference between forward bias and reverse bias.

- The diode is a 'one-way valve'. It allows current to flow through it in only one direction.
- It conducts when it is forward-biased, and does not conduct when reverse-biased.
- When it conducts, there is a voltage drop of about 0.7V across it.
- The light-emitting diode (LED) behaves in the same way.
- It lights up when forward biased, and the current reaches about 10mA. It then has a voltage drop of about 2V across it.
- It needs to be protected from high currents by connecting a resistor in series.

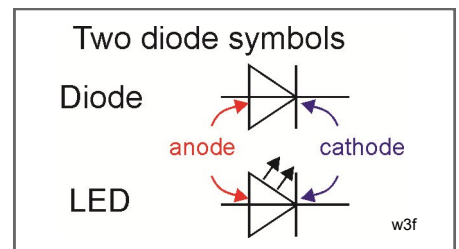

w3f

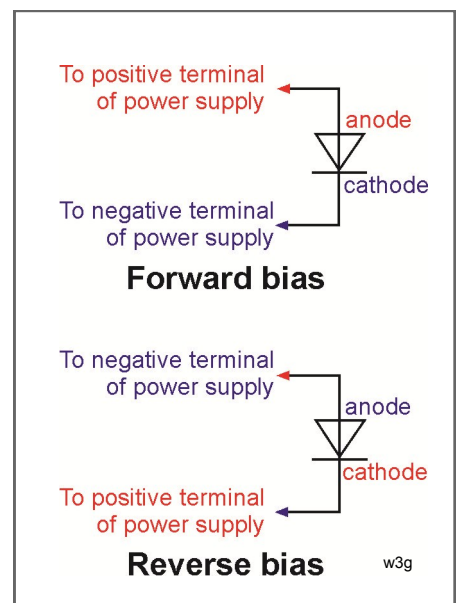

w3g



# Worksheet 4

## Half-wave rectifier

## AC principles for Auto technicians



Most of the auto electrical system runs on DC (direct current.) The alternator, however, generates AC. A device is needed to turn AC into DC so that the alternator can service the needs of the system. This process is called rectification, and the device is the diode.

There are several ways in which diodes can be used to convert the AC voltage to DC. This worksheet looks at the simplest way - the half-wave rectifier.

### Over to you:

Set up the circuit shown in the diagram, using the AC power supply. The  $1k\Omega$  resistor represents all the devices in the auto electrical system.

The diagram shows two positions for the oscilloscope, first connected to the points labelled AC and then connected to the points labelled DC.

If your oscilloscope has two input channels, then connect one to AC, and the other to DC.

If your oscilloscope has only one input channel, then connect it to measure each of the signals in turn. The settings for the oscilloscope are given at the bottom of the page, (identical for both methods.) Record the trace seen on the screen both before and after the diode.

You should find that the current through the  $1k\Omega$  resistor is DC - it does not change direction. However, it is not the smooth DC which you saw in worksheet 1.

The performance of this rectifier can be improved by adding a capacitor. Set up the circuit shown in the second diagram, where a large value capacitor, ( $2200\mu\text{F}$ ), known as a smoothing capacitor, has been added.

Using the same settings as before, use an oscilloscope to record the waveform across the  $1k\Omega$  load (by connecting to the wires labelled DC again.)

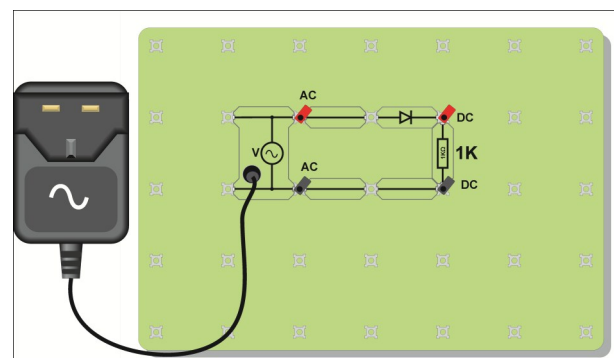

w4b

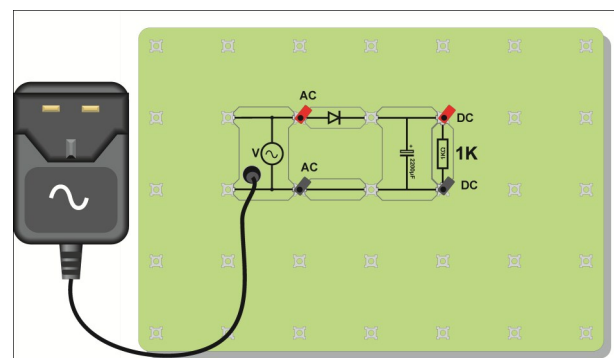

w4c

#### Oscilloscope settings:

**Timebase** - 10ms/div (X multiplier x1)

**Voltage range** - Input A -  $\pm 10\text{V DC}$  (Y multiplier x1)  
(Input B - same settings - if used.)

**Trigger Mode** - Auto

**Trigger Channel** - chA

**Trigger Direction** - Rising

**Trigger Threshold** - 200mV

# Worksheet 4

## Half-wave rectifier

## AC principles for Auto technicians

### So what?

The diode allows current to flow through it (and the  $1k\Omega$  load,) in one direction only. It acts as a small resistor for currents trying to flow in one direction (when it is forward-biased,) and as a very large resistor for currents trying to flow in the other direction, (when reverse-biased.)

The first oscillogram shows a typical trace obtained from the first circuit. The AC input is turned into a DC output (rectified.) Notice that while the output is DC (as it never crosses the 0V line,) it is not steady DC. Compare this with the trace obtained from the DC power supply in worksheet 1. The second oscillogram shows the same signal, using a different time-base setting for the oscilloscope (2ms/div.)

This shows the rectification in more detail. In particular, notice that the DC output, in red, is approximately 0.7V lower than the AC input. The diode does not really conduct until the voltage across it reaches 0.7V. Once it starts to conduct, there is a 0.7V drop across the diode, leaving the DC output 0.7V below the AC input at all points.

The third diagram shows the effect of adding a smoothing capacitor. The output voltage is now both DC and steady. There are issues about the size of the capacitor. These will be explored later.

Simple rectification

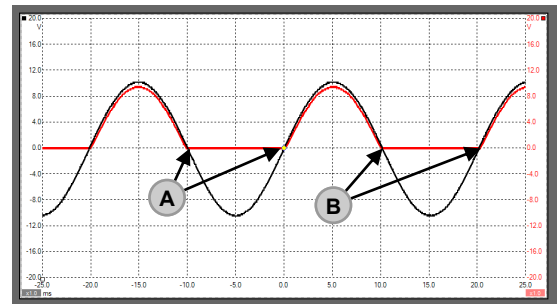

AC — A AC current changes direction here  
DC — B DC current does not change direction

A closer view

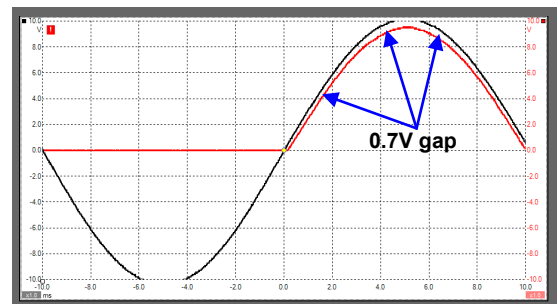

With the capacitor in circuit

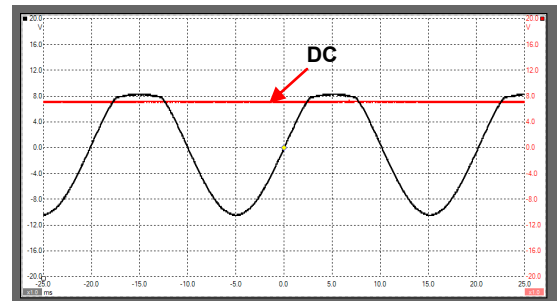

### For your records:

- The process of turning AC into DC is called rectification.
- Half-wave rectification uses only one diode, but results in only half of the AC signal being turned into DC. No current at all flows for half of the time.
- The silicon diode conducts only when it is forward-biased, and there is a voltage of at least 0.7V across it.
- The output of this half-wave rectifier is 0.7V less than the AC input, and is not smooth DC.
- A large capacitor can be connected across the output of the half-wave rectifier to smooth the DC signal produced.

# Worksheet 5

## Full-wave rectifier

## AC principles for Auto technicians

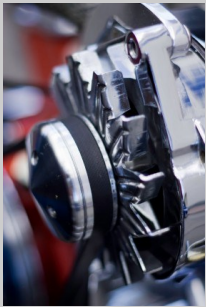

A half-wave rectifier circuit uses only one diode, but it does not make efficient use of the electrical energy on offer. For half of the time, no current at all flows through the load.

A full-wave rectifier overcomes this limitation, but uses a number of diodes to do so, and drops more of the AC voltage across them as a result. Nevertheless, it is the common solution to converting the AC output of the alternator to DC.

### Over to you:

Set up the circuit shown in the diagram, using the AC power supply. Once again, the  $1k\Omega$  resistor represents the load - all the devices in the auto electrical system.

### Important:

**If your oscilloscope has two input channels, DO NOT connect one to AC, and the other to DC. This will short-circuit one of the diodes.** (The reason is explained in more detail on the next page.)

Connect one channel of your oscilloscope to measure the AC signal input. Then connect it to measure the DC signal output. The settings for the oscilloscope are given at the bottom of the page, and are the ones you used in the last investigation. Record both the AC and DC traces.

The DC output varies less than that for half-wave rectification, but it is still not a steady voltage. Try the same remedy as in the last investigation - connect a large capacitor across the output of the full-wave rectifier. The modified circuit is shown in the second diagram.

Using the same settings as before, use oscilloscope to record the waveform across the  $1k\Omega$  load.

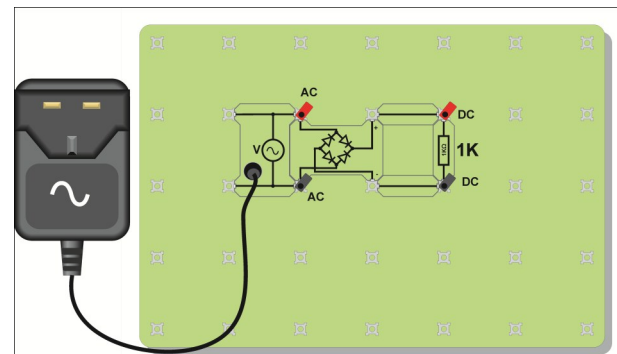

w5b

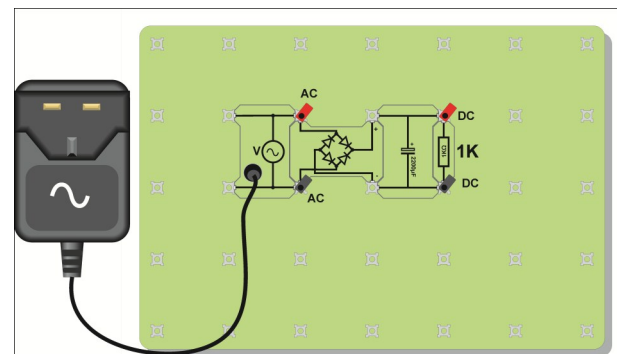

w5c

### Oscilloscope settings:

**Timebase** - 10ms/div (X multiplier x1)

**Voltage range** - Input A -  $\pm 10V$  DC (Y multiplier x1)

**Trigger Mode** - Auto

**Trigger Channel** - chA

**Trigger Direction** - Rising

**Trigger Threshold** - 200mV

# Worksheet 5

## Full-wave rectifier

## AC principles for Auto technicians

### So what?

The circuit diagram for the full-wave rectifier is shown opposite.

On the previous page, it was pointed out that, in this circuit, you cannot measure AC and DC simultaneously using two oscilloscope channels .

To do that, you would connect one channel to points **A** and **C** to measure the AC signal, and the other to points **B** and **D** to measure DC. However, oscilloscope has a common 0V connection between the two channels. This means that you would be connecting points **C** and **D** together, say, through the common oscilloscope connection, and thus be short-circuiting one of the diodes.

The three oscilloscope traces show the AC signal going into the full-wave rectifier, the DC output. and the effect of adding a capacitor to smooth the output.

The DC output, in the middle trace, is an improvement on the half-wave output, in that current flows through the load throughout the AC cycle. Again, this is DC current, because the trace never crosses the 0V line. However, once again, a smoothing capacitor is needed to provide steady DC.

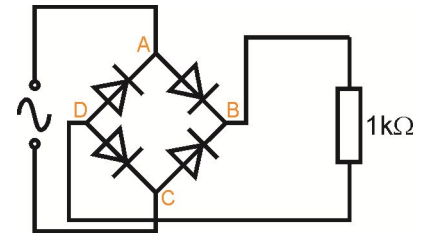

Full wave rectification

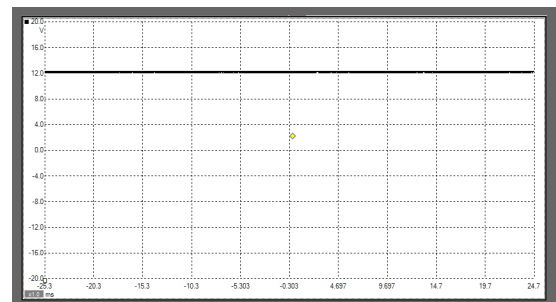
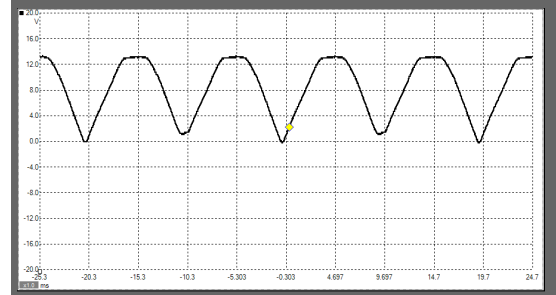
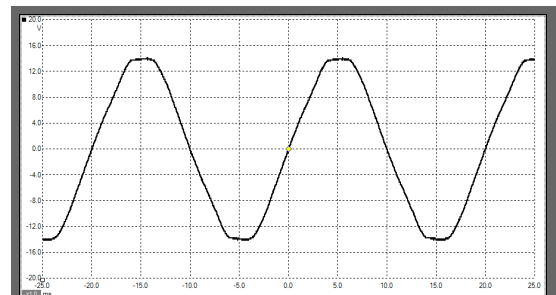

### For your records:

- Full-wave rectification uses at least four diodes, but allows current to flow through the load throughout the AC supply cycle.
- The output of this full-wave rectifier, using four diodes, is 1.4V less than the AC input, and is not smooth DC.
- Again, a large capacitor can be connected across the output of the rectifier to smooth the DC signal produced.

# Worksheet 6

## Ripple voltage

## AC principles for Auto technicians

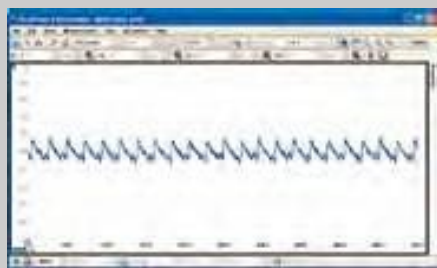

w6a

A lead-acid battery provides a very steady DC voltage, around 12V. Many electronic devices become unstable if subjected to 'noisy' supply voltages.

We have seen that the process of rectification produces DC, but not steady DC, unless a large value capacitor is added to smooth the DC output.

However, how big a capacitor is required?

### Over to you:

The circuit shown in the diagram allows you to investigate the connection between the load attached to a rectifier and the size of capacitor needed to produce a steady DC voltage for that load.

Start with only one lamp connected, and with a 100 $\mu$ F smoothing capacitor. Use oscilloscope to monitor the output of the rectifier, using the settings given at the oscilloscope

In each case, measure the ripple voltage present on the output. (The diagram on the next page illustrates the meaning of ripple voltage.)

Enter your measurements in the table.

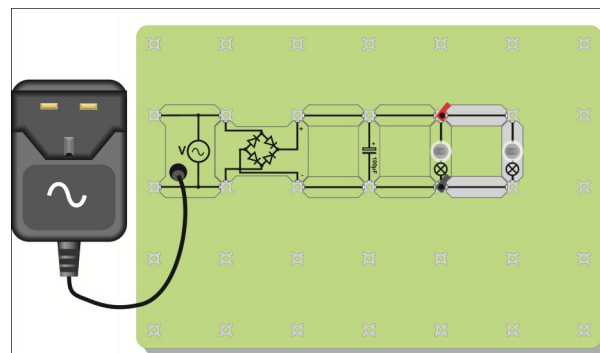

w6b

Load	Capacitor	Ripple voltage
One lamp	100 $\mu$ F	
Two lamps	100 $\mu$ F	
Three lamps	100 $\mu$ F	
Three lamps	2000 $\mu$ F	

#### Oscilloscope settings:

**Timebase** - 10ms/div (X multiplier x1)

**Voltage range** - Input A -  $\pm$ 10V DC (Y multiplier x1)

**Trigger Mode** - Auto

**Trigger Channel** - chA

**Trigger Direction** - Rising

**Trigger Threshold** - 200mV



# Worksheet 6

## Ripple voltage

## AC principles for Auto technicians

### So what?

The diagrams show typical traces for this investigation. The aim is to produce steady DC, like that shown in the trace in worksheet 1. The oscilloscope traces show varying degrees of success in achieving this. The traces for the circuits that used a  $100\mu\text{F}$  capacitor do not show steady DC. The ripple voltage gives a measure of how unsteady they are.

When the diodes are conducting sufficiently, the current drawn by the load (the bulbs) comes from the AC power source. However, when the current through the diodes drops, the bulbs draw current from the smoothing capacitor instead, making it discharge, and causing the voltage across it to drop.

The greater the current demanded, the more the capacitor discharges, and the bigger the ripple voltage gets. The capacitor is a reservoir of electric charge. In a water reservoir, the water level drops when consumers draw water from it. Eventually, it is topped up again, when it rains. The capacitor is topped up with electric charge the next time the current through the diodes increases sufficiently.

As more lamps are added, more current is drawn and the ripple voltage gets bigger (worse). The solution is to use a bigger capacitor to smooth the supply voltage. The effect of increasing the smoothing capacitor to  $2200\mu\text{F}$  is shown in the bottom trace.

The final diagram shows how the ripple voltage forms as a result of the load demanding current from the capacitor.

### For your records:

Copy the final diagram showing how the ripple voltage forms.

- The ripple voltage indicates how unsteady the output of the rectifier is.
- The ripple voltage increases as more current is demanded by the load.
- The bigger the smoothing capacitor, the smaller the ripple voltage.

Ripple with one bulb and  $100\mu\text{F}$  capacitor

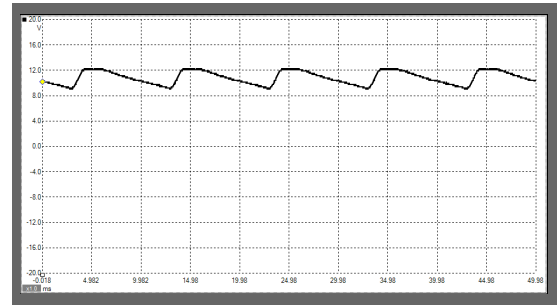

w6d

Ripple with two bulbs and  $100\mu\text{F}$  capacitor

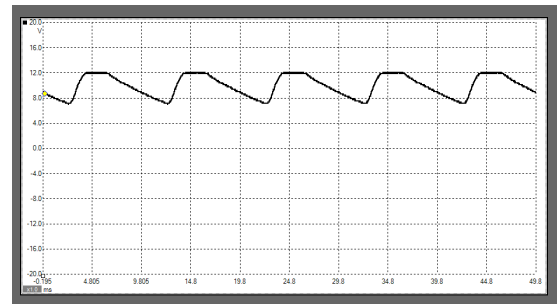

w6e

Ripple with three bulbs and  $100\mu\text{F}$  capacitor

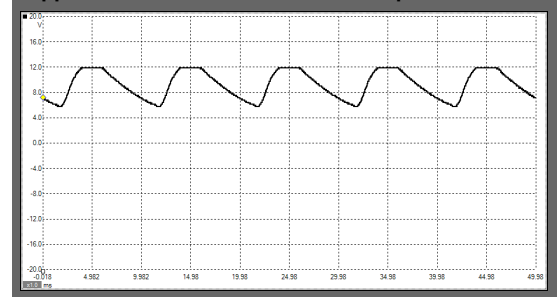

w6f

Ripple with three bulbs and  $2000\mu\text{F}$  capacitor

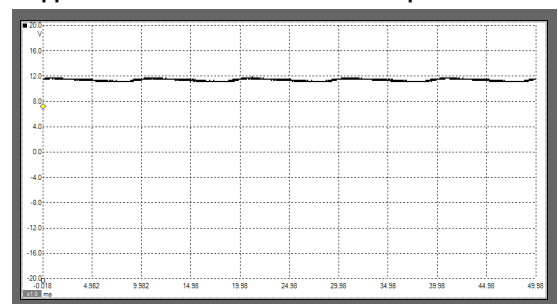

w6g

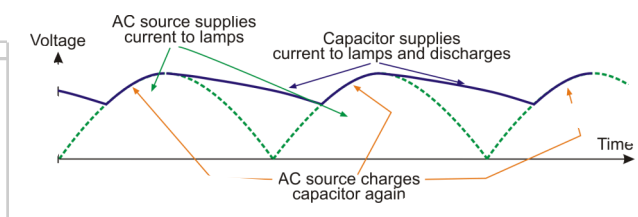

w6c

# Worksheet 7

## Inductors

# AC principles for Auto technicians

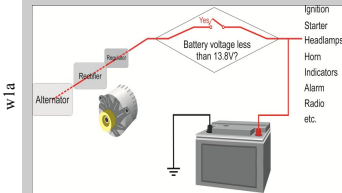

Resistors oppose electric currents. Inductors oppose *changes* to electric currents, but the mechanism is different.

An electric current flowing in the inductor, sets up a magnetic field. Increasing the current means increasing the magnetic field, and that takes energy from the current, opposing the increase. Reducing the current means reducing the magnetic field, and that releases energy which tries to maintain the current.

Inductors behave rather like flywheels on a rotating shaft. Their angular momentum tries to keep the shaft rotating at the same speed. When the shaft starts to slow down, the stored energy in the flywheel tries to keep it going. When the shaft tries to speed up, the flywheel requires energy to speed it up, and so the flywheel seems to resist the change.

### Over to you:

Connect a 47mH inductor in series with the AC power supply/signal generator, as shown in the circuit diagram.

Use enough connecting links so that the current can be measured at point **A**.

The photograph shows one way to build the circuit.

Set the AC signal generator to output a frequency of 50Hz.

Remove the connecting link at **A**, and connect a multimeter, set to read up to 20mA **AC**, in its place.

Record the current flowing at point **A** in the table.

Remove the multimeter and replace link **A**.

Set up the multimeter to read **AC** voltages of up to 20V and connect it in parallel with the inductor.

Record the voltage in the table.

Now change the power supply frequency to 100Hz and repeat the measurements. Record them in the table.

Do the same for frequencies of 500Hz and 1kHz (1,000Hz). Again, record these measurements in the table.

The table allows you to take two sets of measurements at each frequency to improve the accuracy of your results.

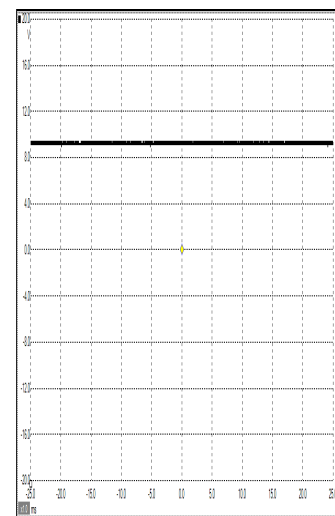
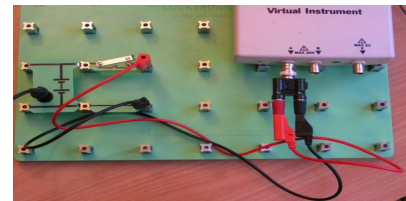

Frequency	Current I	Voltage V
50Hz		
100Hz		
500Hz		
1kHz		

# Worksheet 7

## Inductors

### AC principles for Auto technicians

#### So what?

- Resistors behave in a straightforward way, spelled out by Ohm's Law. If you double the current through the resistor, you double the voltage dropped across it, and so on. The ratio of voltage to current is called resistance.
- Inductors are more complicated. If you double the *rate of change* of current through the inductor, you double the voltage dropped across it, and so on. The ratio of voltage to rate of change of current is called **inductance L**.
- The higher the frequency of the AC, the faster the current changes, and so the greater the voltage drop across the inductor. In other words, the voltage dropped depends on the frequency of the AC supply. This is **not** the case with pure resistors, where the frequency has no effect.
- We describe this behaviour in terms of the **(inductive) reactance,  $X_L$** , defined, in the same way as resistance, as  $X_L = V / I$ . As a result, the units of reactance are ohms.
- The inductive reactance measures the opposition of the inductor to changing current. The higher the frequency, **f**, the greater the change in current. In fact, the formula for inductive reactance is:
 
$$X_L = 2 \pi f L$$
- Using your measurements, calculate the  $X_L$ , from the formula:
 
$$X_L = V / I$$
 and compare that with the value calculated using
 
$$X_L = 2 \pi f L \text{ where } L = 47\text{mH}$$
- Carry out those calculations and fill in the following table with your results:

Frequency	Inductive reactance $X_L = V / I$	Inductive reactance $X_L = 2 \pi f L$
50Hz		
100Hz		
500Hz		
1kHz		

#### For your records:

The opposition of an inductor to changing currents is called inductive reactance,  $X_L$ , given by the formula:  $X_L = 2 \pi f L$  where  $f$  is the frequency of the AC signal, and  $L$  is the inductance of the inductor.

It can also be obtained from the formula  $X_L = V / I$ , where  $V$  and  $I$  are RMS voltage and current respectively.

Inductance is measured in a unit called the henry, (H) and reactance in ohms.

Complete the following:

When the AC frequency is doubled, the inductive reactance is .....

# Worksheet 8

## Capacitors

### AC principles for Auto technicians



An electric current sets up a **magnetic** field inside an inductor. This then opposes changes to electric *currents*.

An electric current sets up an **electric** field across the plates of a capacitor. This opposes changes to the *voltage* applied to the capacitor. Before the voltage can increase, electrons must flow onto the plates of the capacitor, increasing the electric field. This requires energy. When the voltage tries to decrease, electrons flow off the plates, reducing the electric field. These electrons try to maintain the voltage across the capacitor.

Capacitors behave rather like buckets in a water circuit. They must fill up before any water flows anywhere else in the circuit. When the flow of water starts to fall, excess water flows from the bucket, trying to maintain the flow.

#### Over to you:

Connect a  $1\mu\text{F}$  capacitor in series with the AC power supply, as shown in the circuit diagram.

Use enough connecting links so that the current can be measured at point **A**.

Set the AC power supply to output a frequency of 50Hz.

Remove the connecting link at **A**, and connect a multimeter, set to read up to 20mA AC, in its place. Record the current flowing at point **A** in the table.

Remove the multimeter and replace link **A**.

Set up the multimeter to read AC voltages of up to 20V and connect it in parallel with the capacitor. Record the voltage in the table.

Now change the power supply frequency to 100Hz and repeat the measurements. Record them in the table.

Do the same for frequencies of 500Hz and 1kHz (1,000Hz). Again, record these measurements in the table.

As before, the table allows you to take two sets of measurements at each frequency to improve the accuracy of your results.

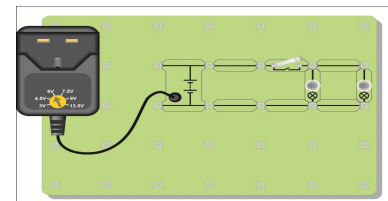

w2b

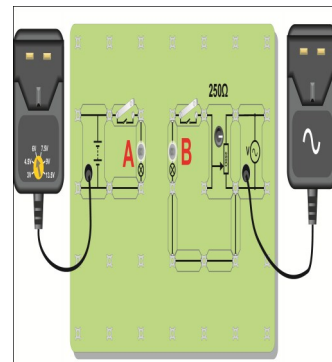

w2c

Frequency	Current I	Voltage V
50Hz		
100Hz		
500Hz		
1kHz		

# Worksheet 8

## Capacitors

### AC principles for Auto technicians

#### So what?

- With resistors, when you double the *current* through the resistor, you double the voltage dropped across it, and so on. With inductors, when you double the rate of change of *current* through the inductor, you double the voltage dropped across it, and so on.
- Capacitors oppose a changing voltage. The faster the rate of change of *voltage*, the greater the current that must flow to charge or discharge the capacitor. The higher the frequency of the AC, the faster the *voltage* changes, and so the greater the current flowing in the circuit. In other words, the current depends on the frequency of the AC supply.
- We describe this behaviour in terms of the **capacitive reactance**,  $X_C$ , defined, in the same way as resistance, as  $X_C = V / I$ . As before, the units of reactance are ohms.
- The capacitive reactance measures the opposition of the capacitor to changing current. The higher the frequency,  $f$ , the greater the change in voltage, and the greater the current flow. The formula for capacitive reactance is:  $X_C = 1 / (2 \pi f C)$
- Capacitors are very much a mirror image of inductors. As the frequency of the AC supply increases, an inductor offers more opposition, (i.e. the inductive reactance increases, and the current decreases) whereas a capacitor offers less opposition, (i.e. the capacitive reactance decreases, and the current increases).
- Using your measurements, calculate the  $X_C$ , using both :  

$$X_C = V / I \quad \text{and} \quad X_C = 1 / (2 \pi f C) \quad \text{where } C = 1 \mu\text{F}$$
- Carry out those calculations and fill in the following table with your results:

Frequency	Capacitive reactance $X_C = V / I$	Capacitive reactance $X_C = 1 / (2 \pi f C)$
50Hz		
100Hz		
500Hz		
1kHz		

#### For your records:

The opposition of a capacitor to changing voltage is called capacitive reactance,  $X_C$ , given by the formula:  $X_C = 1 / (2 \pi f C)$  where  $f$  is the frequency of the AC signal, and  $C$  is the capacitance of the capacitor.

It can also be obtained from the formula  $X_C = V / I$ , where  $V$  and  $I$  are RMS voltage and current respectively.

Capacitance is measured in farads (F), though, in practice, this unit is too large.

Most capacitors have values given in microfarads ( $\mu\text{F}$ ).

Complete the following:

When the AC frequency is doubled, the capacitive reactance is .....



# Instructor Guide

## AC principles for Auto technicians

### About this course

#### Introduction

The course is essentially a practical one. Locktronics equipment makes it simple and quick to construct and investigate electrical circuits. The end result can look exactly like the circuit diagram, thanks to the symbols printed on each component carrier.

#### Aim

The course introduces students to the use of AC devices in auto electrics. It does so through a series of practical experiments which allow students to unify theoretical work with practical skills.

#### Prior Knowledge

It is recommended that students have followed the 'Electricity Matters 1' and 'Electricity Matters 2' courses, or have equivalent knowledge and experience of building simple circuits, and using multimeters.

#### Learning Objectives

On successful completion of this course the student will:

- recall that the shape of AC signal delivered by AC power sources is called **sinusoidal**;
- define the term **period** of the signal, and know that it is measured in seconds;
- define the term **frequency** of the signal, and know that it is measured in hertz;
- be able to use the formula: Frequency = 1 / period;
- define the **RMS** value of a sinusoidal AC signal as the equivalent DC voltage;
- be able to use the formula: Peak value = RMS value  $\times \sqrt{2}$ ;
- recognise the symbols for a diode and a LED, and distinguish between forward and reverse bias;
- recall that a diode conducts when forward-biased, and does not conduct when reverse-biased;
- know that a silicon diode has a voltage drop of about 0.7V across it when conducting current;
- recall that a LED lights when forward biased with  $\sim 10\text{mA}$  of current through it and a voltage drop of  $\sim 2\text{V}$  across it;
- know that a LED needs to be protected from high currents by connecting a resistor in series;
- define **rectification** as the process of turning AC into DC;
- know that half-wave rectification uses only one diode, but produces a DC current for only half of the time;
- recall that half-wave rectification produces a DC output voltage which is  $\sim 0.7\text{V}$  less than the peak AC voltage;
- know that full-wave rectification uses at least four diodes, but produces a DC current throughout the AC cycle;
- recall that full-wave rectification produces a DC output voltage which is  $\sim 1.4\text{V}$  less than the peak AC voltage;
- know that a large value capacitor connected across the rectifier output will smooth the DC signal produced;
- be able to measure the ripple voltage present in a DC power supply;
- be able to relate the size of the capacitor, needed to produce smoothing, to the load current;
- know that the opposition of an inductor to changing currents is called **inductive reactance**;
- be able to use the formula:  $X_L = 2 \pi f L$  to calculate inductive reactance;
- be able to use the formula  $X_L = V / I$ , where V and I are RMS voltage and current respectively.
- know that inductance is measured in a unit called the henry, (H) and that reactance is measured in ohms;
- know that the opposition of a capacitor to changing voltage is called **capacitive reactance**;
- be able to use the formula:  $X_C = 1 / (2 \pi f C)$  to calculate capacitive reactance;
- be able to use the formula  $X_C = V / I$ , where V and I are RMS voltage and current respectively;
- know that capacitance is measured in farads (F), or microfarads ( $\mu\text{F}$ );
- know that inductors usually have some resistance as well, due to the long length of wire used in construction;

# Instructor Guide

## AC principles for Auto technicians

### What the student will need:

To complete the Advanced Electrical Principles DC and AC courses, the student will need the parts shown in the table.

In addition the student will need:

- 2 multimeters, capable of measuring AC currents in the range 0 to 20mA, and AC voltages in the range 0 to 15V. For this we recommend part LK1110.
- 1 function generator capable of generating sinusoidal AC signals with frequencies up to 10kHz. For this we recommend part HP8990.
- 1 oscilloscope with two traces. You have a choice here between a conventional oscilloscope and a PC based oscilloscope. For this we recommend part LK4679 which is a conventional oscilloscope. We also recommend the HP4679 PICOscope which is a 5MHz dual trace PC based scope, and HP6730 which is a more powerful 50MHz scope with integral CAN bus decoding.

Qty	Code	Description
2	LK6209	Switch on/off (stay put, sideways swivel strip)
12	LK5250	Connecting Link
1	LK5202	Resistor - 1K, 1/4W, 5% (DIN)
1	LK5214	Potentiometer, 10K (DIN)
1	LK5208	Potentiometer 250 ohm (DIN)
1	LK6202	Capacitor, 100uF, Electrolytic, 16V
1	LK6203	Capacitor, 2,200 uF, Electrolytic, 25V
1	LK6205	Capacitor, 1 uF, Polyester
1	LK6214R2	Choke 47mH
3	LK2347	MES bulb, 6V, 0.04A
3	LK5291	Lampholder carrier
1	LK8900	7 x 5 baseboard with 4mm pillars
1	LK5266	Bridge rectifier (1N4001)
1	LK6205	Capacitor, 1 uF, Polyester
1	HP4039	Lid for plastic trays
1	HP5540	Deep tray
1	HP9564	62mm daughter tray
1	HP7750	Locktronics daughter tray foam insert
1	LK2340	AC power supply carrier
1	HP2666	International power supply with adaptors
1	LK8275	Power supply carrier with battery symbol
2	LK5555	Red 2mm to 4mm Logic Gate lead
2	LK5556	Black 2mm to 4mm Logic Gate lead
1	LK5243	Diode (1N4001) power 50V
1	HP6529	BNC male to dual 4mm binding post

### Power sources:

The investigations in this module require two power sources, one AC and the other DC. Both of these are available as 'plug-top' power supplies.

The HP2666 is an adjustable DC power supply offering output voltages of either 3V, 4.5V, 6V, 7.5V, 9V or 12V, with currents typically up to 1A. The voltage is changed by turning the selector dial just above the earth pin until the arrow points to the required voltage. (The instructor may decide to make any adjustment necessary to the power supply voltage, or may allow students to make those changes.)

The HP3728 is a fixed, UK only, 12V AC power supply, delivering currents of up to 1A. It is connected to the rest of the Locktronics circuit by an AC voltage source carrier. Note that any AC power supply of between 8V and 13V can be used with these experiments.

# Instructor Guide

## AC principles for Auto technicians

### Using this course:

It is expected that the series of experiments given in this course is integrated with teaching or small group tutorials which introduce the theory behind the practical work, and reinforce it with written examples, assignments and calculations.

The worksheets should be printed / photocopied / laminated, preferably in colour, for the students' use. Students should be encouraged to make their own notes, and copy the results tables and sections marked 'For your records' for themselves. They are unlikely to need their own permanent copy of each worksheet.

Each worksheet has:

- an introduction to the topic under investigation;
- step-by-step instructions for the investigation that follows;
- a section headed 'So What', which aims to collate and summarise the results, and offer some extension work. It aims to encourage development of ideas, through collaboration with partners and with the instructor.
- a section headed 'For your records', which can be copied and completed in students' exercise books.

This format encourages self-study, with students working at a rate that suits their ability. It is for the instructor to monitor that students' understanding is keeping pace with their progress through the worksheets. One way to do this is to 'sign off' each worksheet, as a student completes it, and in the process have a brief chat with the student to assess grasp of the ideas involved in the exercises it contains.

### Time:

It will take students between seven and nine hours to complete the worksheets.

It is expected that a similar length of time will be needed to support the learning that takes place as a result.

# Instructor Guide

Scheme of work

## AC principles for Auto technicians

Worksheet	Notes for the Instructor	Timing
1	<p>It is easy to classify auto electrical systems as 12V DC, running off the lead-acid battery. The aim of this worksheet is to show that there are other aspects to this electrical system as well, and in particular, that the alternator outputs AC which is converted to DC, used to charge the lead-acid cell, when necessary, and provide electrical power for the auto electrical system. It seeks to distinguish between direct current (DC) and alternating current (AC) electrics.</p> <p>In studying AC, students will use new techniques and measuring instruments. Since alternating currents and voltages change rapidly over time, some means of 'freezing' their behaviour is needed. For this module, we use the A PC based oscilloscope (essentially a digital storage oscilloscope) to capture the varying AC voltages, but any kind of oscilloscope can be used. We have used a PC oscilloscope called 'Picoscope' and some information on how this works is given at the back of the worksheets.</p> <p>This may be the first time that students have used an oscilloscope, or equivalent, and this first investigation can be viewed as a training exercise. A Help Sheet is provided to assist them in setting up and interpreting the traces produced by Picoscope. Each worksheet lists the recommended settings for that investigation.</p> <p>Sample traces are provided to reassure students that their results are in line with expectations. Because of the variability in the characteristics of mass-produced electronic devices, the precise details of the traces obtained may vary a little from the exemplars. Characteristics of power supplies also vary so students may end up with slightly different traces. Instructors should explain to students that such variation is to be expected in the 'real world'.</p> <p>Students commonly misinterpret voltage/time graphs, displaying voltage signals. They expect DC to be steady DC. A varying DC signal confuses them. Instructors should stress that DC means that the current is flowing the same way around the circuit all the time. It never changes direction. The size of the voltage and current may change, but if the flow is always in the same direction, it is DC. Instructors should point out that the electric current changes direction only if the signal crosses the 0V axis of the graph.</p> <p>This investigation goes on to introduce the terms period and frequency for AC signals, and to give the equation linking them. As with all mathematical relationships, practice drives home the ideas. Instructors should ensure that the students are given plenty of practice in calculating equivalent periods and frequencies.</p> <p>It is advisable to remind students about common prefixes, such as kilo, milli, and micro at this point. The time axis of the oscilloscope traces will be graduated in milliseconds, for example.</p>	25 - 40 mins

# Instructor Guide

Scheme of work

**AC principles for  
Auto technicians**

Worksheet	Notes for the Instructor	Timing
2	<p>This worksheet aims to compare the effects of AC and DC, and to come up with a quantity that relates the two.</p> <p>The investigation looks at the light output produced from two lamps, one lit with DC power, the other with AC. When the light outputs are identical, the power delivered by the two forms of electricity is comparable.</p> <p>One weakness in this approach is that bulbs are mass produced devices, so that even though they are supposed to be identical, they can vary slightly in performance. Hence the first part of the investigation has the two connected in parallel to see how well matched they are. Since they are in parallel, they have the same voltage across them, and so should produce equal amounts of light. The students are asked to change one of the bulbs if they do not match. It is advisable to have a number of spare bulbs available in case this happens.</p> <p>Another issue is how well the human eye can compare the brightness of the two bulbs. We can do nothing to influence this, and it remains a likely source of error if the results for 'RMS' do not match theory.</p> <p>The analysis on page 6 introduces the term <b>RMS</b> as the measure that allows us to compare AC and DC power sources. There is no attempt to justify or explain why this is so. To do so requires integral calculus, and is beyond the range of this course. Fuller treatment is unlikely to improve the student's understanding anyway. The inquisitive might be satisfied by telling them that 'RMS' stands for 'root-mean-squared', and is the result of taking the square root of the mean (average) of the square of the AC voltage, taken over one complete cycle. The voltage is 'squared' to get rid of the minus sign, since the voltage is negative for half of the cycle. This recognises that the bulb lights, and so delivers power, no matter which way the current flows through it. The voltage, and so the square of the voltage, varies over the AC cycle, and so the average is taken. Since this is the average of (voltage)<sup>2</sup>, it is necessary to take the square root to get back to plain straightforward voltage. The result gives us a measure that can be compared with DC.</p> <p>As in the previous investigation, the students are given a formula. This time it links the RMS value and peak value of the AC signal:</p> $\text{Peak value} = \text{RMS value} \times \sqrt{2}$ <p>Again, the advice is to give plenty of practice at applying this formula, to give them confidence.</p>	30 - 45 mins



# Instructor Guide

## Scheme of work

## AC principles for Auto technicians

Worksheet	Notes for the Instructor	Timing
3	<p>Ohm's law always seems to loom large in courses on electricity. The reality is that only a very small number of components come anywhere near obeying Ohm's law. This needs to be made clear, as otherwise the prominence given to the law can give the misleading impression that it commonly applies.</p> <p>Here the students meet a component that does not obey Ohm's law, the diode. The circuit diagram of the arrangement is included in the hope that it makes clear the role of the variable resistor. When Ohm's law applies, doubling the current through a device doubles the voltage across it, and so on. The students need a way of controlling the current through the diode, and the variable resistor, set up as a voltage divider, provides that.</p> <p>The current through the diode is varied, and measured, and at each stage the resulting voltage across the diode is measured. The set of results obtained is then expressed as a graph. Ohm's law behaviour would result in a straight line graph. The behaviour of the diode definitely does not. The students are given a guide to the resulting shape of the graph on page 7.</p> <p>The terms 'forward-biased' and 'reverse-biased' are introduced, but will need reinforcement by the instructor. The circuit symbol for the diode helps the student identify which bias is present. The symbol contains an arrow that points in the direction in which current is allowed to flow through the diode. Current flows from positive to negative. If this current direction matches that of the arrow, then the diode is forward biased, and current flow takes place.</p> <p>The results refer to diodes and also to a very common form of diode, the light-emitting diode (LED.) They give the generalised, and approximate, result that the forward voltage drop for a (power) diode is 0.7V and for a lit LED is 2V.</p>	25 - 40 mins
4	<p>Earlier investigations focussed on comparing the effects of AC and DC. Now we look at the process of converting AC to DC, called rectification. There are several ways to implement rectification. We look at two, known as half-wave and full-wave rectification. Full-wave rectification is the subject of worksheet 9. Here we look at half-wave rectification.</p> <p>The students need reminding about the significance of voltage/time graphs. The current changes direction only when the trace crosses the 0V line. If it never crosses, then the current is DC, but not necessarily steady DC.</p> <p>Half-wave rectification uses the one-way conduction of a diode, to ensure that the current through the load never reverses i.e. is always DC. The rectifier circuit is simple - just add a diode in series with the load. However, it is not very efficient, as no current at all flows during the negative half-cycle of the AC supply. A half-wave rectifier rectifies only half of the AC 'wave'. When this is not a problem, use half-wave rectification. One such case is the simple lead-acid battery trickle charger, where it is accepted that the charging process will take some time to complete.</p> <p>The half-wave rectifier does not provide smooth DC. There is a large ripple voltage (variation in output voltage.) This can be reduced substantially by adding a high value capacitor in parallel with the load. To keep the size down, this is usually an electrolytic capacitor, and so care must be taken to ensure that it is connected the right way round, as shown in the diagram on page 9. The results also show that the output is 0.7V lower because the available voltage is shared between the conducting diode and the load.</p>	25 - 40 mins

# Instructor Guide

Scheme of work

## AC principles for Auto technicians

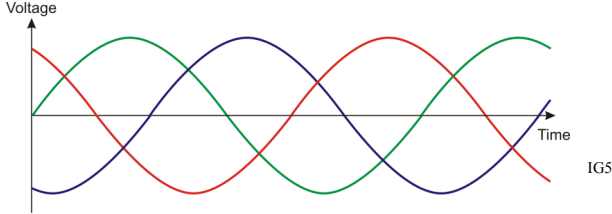
Worksheet	Notes for the Instructor	Timing
<p><b>5</b></p>	<p>Now the student investigates full-wave rectification. As its name suggests, it makes use of both the positive and negative half-cycles of the AC supply. A DC current can flow all the time through the load, making more efficient use of the supply.</p> <p>This improved efficiency comes at the price of more complex circuitry. At least four diodes are used to rectify the AC supply.</p> <p>Often, auto alternators output what is known as 3-phase AC, effectively three AC signals, superimposed on each other, but staggered in time. The alternator contains three independent sets of coils. The rotating electromagnet generates a separate AC signal in each set of coils. For more details, see the 'Motors and Generators' module. This idea is shown in the next diagram.</p>  <p>When this is the case, full-wave rectification will need six diodes.</p> <p>It is important that students do not try to use two oscilloscope input channels to capture two signals at the same time unless they have a common ground. The outer casing of the BNC connectors are joined. Using two inputs, connected to different parts of a circuit, can short-circuit those parts. This is discussed on page 12, using a circuit diagram of the full-wave rectifier to make the issue clearer. However, instructors may wish to discuss this problem with students because of its wider implications for the use of test instruments.</p>	
<p><b>6</b></p>	<p>We are aiming to generate steady DC power from the alternator. Producing DC is not difficult. The properties of diodes make this straightforward. The problem is in smoothing it.</p> <p>Measuring the ripple voltage gives an indication of just how steady is the power supply. It is measured as the variation in the supply voltage, but is often quoted as a percentage of the supply voltage.</p> <p>When the current drawn from the power supply increases, the ripple voltage increases. The bigger the capacitance of the smoothing capacitor, the smaller the ripple voltage. This investigation explores these issues, by adding more and more lamps, to draw bigger currents from the rectifier</p> <p>In reality, the smoothing capacitor is chosen to offer a sufficiently low ripple voltage for the maximum current demand expected. If greater smoothing is required, then a voltage regulator stage is added after the full-wave rectifier.</p> <p>This investigation looks at smoothing the output of a full-wave rectifier. The same approach can be used for half-wave circuits, but there the task is even greater. Roughly speaking, the capacitor size must be doubled to offer the same ripple voltage from a half-wave rectifier.</p> <p>The timebase settings for the oscilloscope are different in this investigation in order to show the ripple in more detail.</p>	

# Instructor Guide

Scheme of work

**AC principles for  
Auto technicians**

Worksheet	Notes for the Instructor	Timing
7	<p>The aim of the investigation is introduce the student to the effects of inductive reactance. The AC power supply is replaced by a function generator, so that the effect of changing the frequency can be explored. As students may be unfamiliar with using the function generator, the instructor should check that they know how to set the frequency</p> <p>For those returning to electrical studies after a break, it is an opportunity to re-visit the skills involved in using multimeters to measure current and voltage. In particular, students should be reminded that voltage measurements can be made without interrupting the circuit, as the multimeter is then connected in parallel with the resistor under investigation. On the other hand, to measure current at a point in the circuit, the circuit must be broken at that point and the multimeter inserted there to complete the circuit.</p> <p>Instructors need to be aware that the low current ranges on most multimeters are protected by internal fuses. If a student is having difficulty in getting readings from a circuit, it may be that this internal fuse has blown. It is worth having some spare multimeters available, and the means to change those fuses, to streamline the lesson.</p> <p>A comparison is made between resistors, which oppose current, and inductors, which oppose changing current. The instructor might wish to elaborate on this, and expand on what is meant by '<i>rate of change of current</i>'.</p> <p>Students often find it confusing that reactance is measured in ohms. The point should be made that this comes from the definition of inductive reactance and a formula that looks like, but has nothing to do with, Ohm's law. The opposition caused by resistors is the resistance. However, the opposition caused by inductors is not the inductance, but the inductive reactance.</p> <p>They will need plenty of practice in calculating this from the formula: <math>X_L = 2 \pi f L</math> as they confuse the terms f and L, and find it difficult to convert multipliers such as '<i>milli</i>' often used with inductance.</p>	30 - 45 mins
8	<p>This is the introductory worksheet for capacitors, equivalent to Worksheet 7.</p> <p>It is important that students appreciate that inductors and capacitors are really mirror-images of each other. The former sets up a magnetic field, the latter an electric field. The former has a slowly increasing current, once a voltage is applied to it. The latter has a slowly increasing voltage across it, as a current flows in the circuit. Inductors oppose a changing current, capacitors a changing voltage. This opposition increases with frequency in inductors, but decreases with frequency in capacitors.</p> <p>As pointed out above, there is widespread confusion among students over the difference between reactance and, in this case, capacitance. The opposition caused by resistors is the resistance. However, the opposition caused by capacitors is not their capacitance, but their capacitive reactance.</p> <p>They will need plenty of practice in calculating this from the formula: <math>X_C = 1 / 2 \pi f C</math> as they find it difficult to convert multipliers such as '<i>micro</i>' and '<i>nano</i>'.</p>	30 - 45 mins

# Using the Picoscope

## AC principles for Auto technicians

The Picoscope uses the same controls as an oscilloscope:

### Timebase:

- controls the scale on the time (horizontal) axis;
- spreads out the trace horizontally if a lower number is used.

### Voltage sensitivity:

- controls the scale on the voltage (vertical) axis;
- spreads out the trace vertically if a lower number is used.

### AC or DC:

- shows only varying voltages if AC is chosen (so centres the trace on 0V vertically;)
- shows the true voltage levels if DC is chosen.

### Trigger:

- looks at the selected signal to decide when to set off on the next trace;
- waits for that signal to reach the voltage level selected before starting;
- can be either when a rising or a falling signal reaches that voltage level.

### Stop / Go:

- 'Stop' indicates that the trace is 'frozen' (i.e. showing a stored event;)
- 'Go' shows that the trace is showing events in real-time;
- Click on the box to change from one to the other.

The settings are selected on-screen using the drop-down boxes provided.

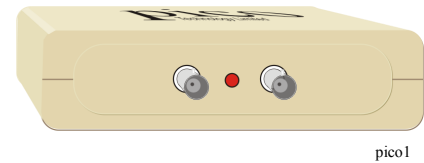

pico1

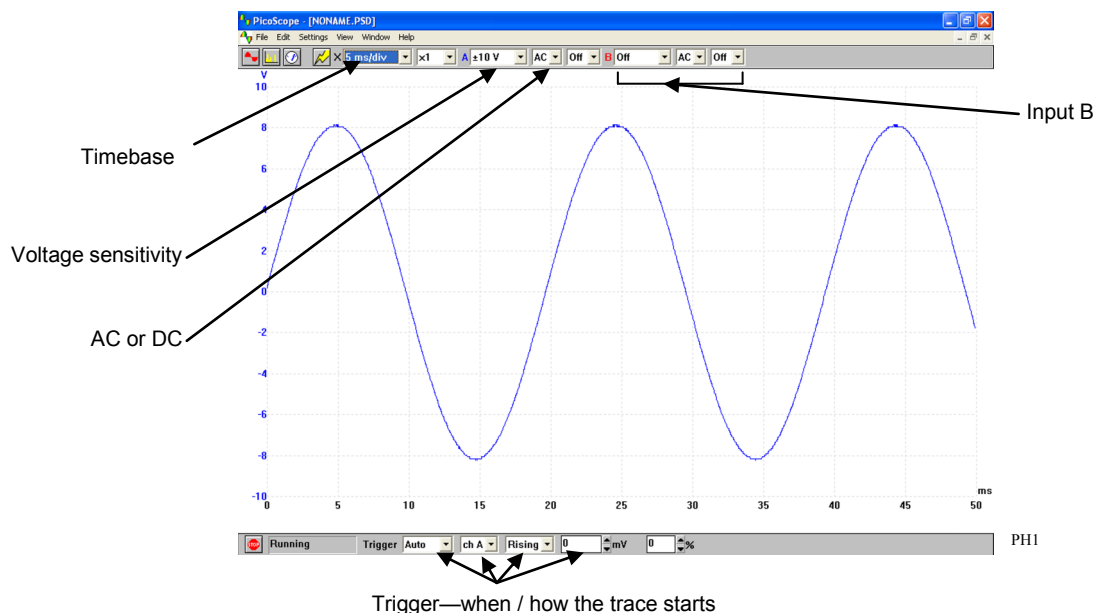

In this trace:

Timebase = 5 ms/div, so the time scale (horizontal axis) is marked off in 5 ms divisions.

Voltage sensitivity =  $\pm 10$  V, so the maximum possible voltage range (vertical axis) is +10V to -10V.

Trigger - Auto - so will show any changes in the signal as they happen;

Ch A - so looks at the signal on channel to decide when to start the trace;

Rising - so waits for a rising voltage to reach the threshold;

Threshold - 0 mV - so starts the trace when the signal on channel A rises through 0V.

# Using the Picoscope

## AC principles for Auto technicians

More Picoscope traces *for the same signal*:

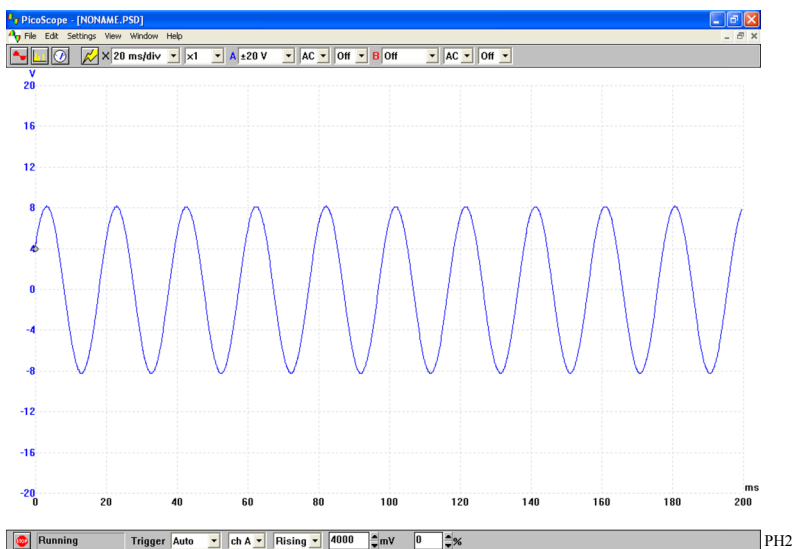

In this trace:

**Timebase** = 20ms/div,

- the time scale (horizontal axis) is marked off in 20 ms divisions;
- the trace is 'squashed' horizontally, but shows a greater time duration.

**Voltage sensitivity** =  $\pm 20$  V,

- the maximum possible voltage range (vertical axis) is +20V to -20V;
- the trace is 'squashed' vertically, but shows a greater possible voltage range.

**Trigger** - now 4000 mV, and so the trace does not start until the signal on channel A reaches 4000mV (4V)

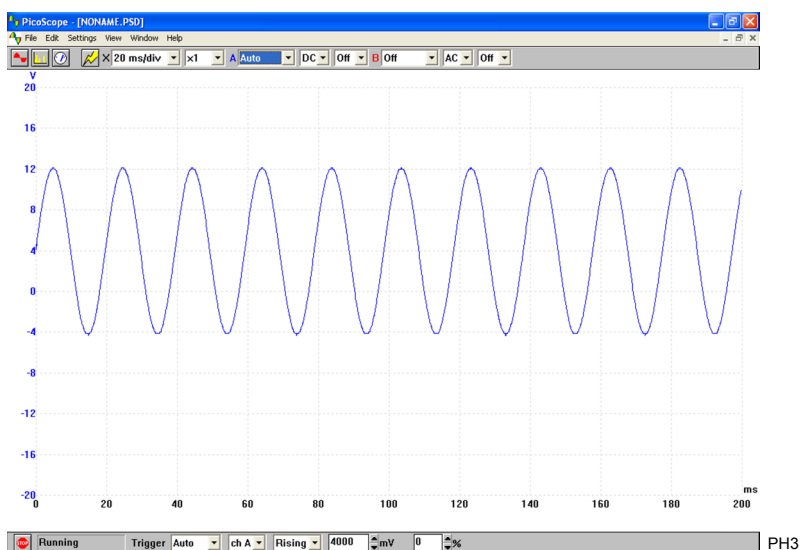

In this trace:

the settings are identical except that the DC option is chosen. The trace now reveals that, in addition to the AC signal, there is a steady DC component of +4V. The trace is centred vertically on 4V, not 0V. The AC component makes it swing by  $\pm 8$ V, i.e. between -4V and +12V.

# Version control

## **AC principles for Auto technicians**

**01 04 2010**

First version released

**08 06 2010**

Many pages

Amendments following external review.